

NP70-10

Mod.
NF74E10T CR0951810
NF76E10T CR0951820

FRIGGITRICI ELETTRICHE 10+10 LITRI
ELECTRIC HEATED FRYERS 10+10 LITERS
FRITEUSES ELECTRIQUES 10+10 LITRES
ELEKTRO FRITEUSEN 10+10 LITERS

Зип.Общепит
vsezip.ru
+7(812)987-08-81

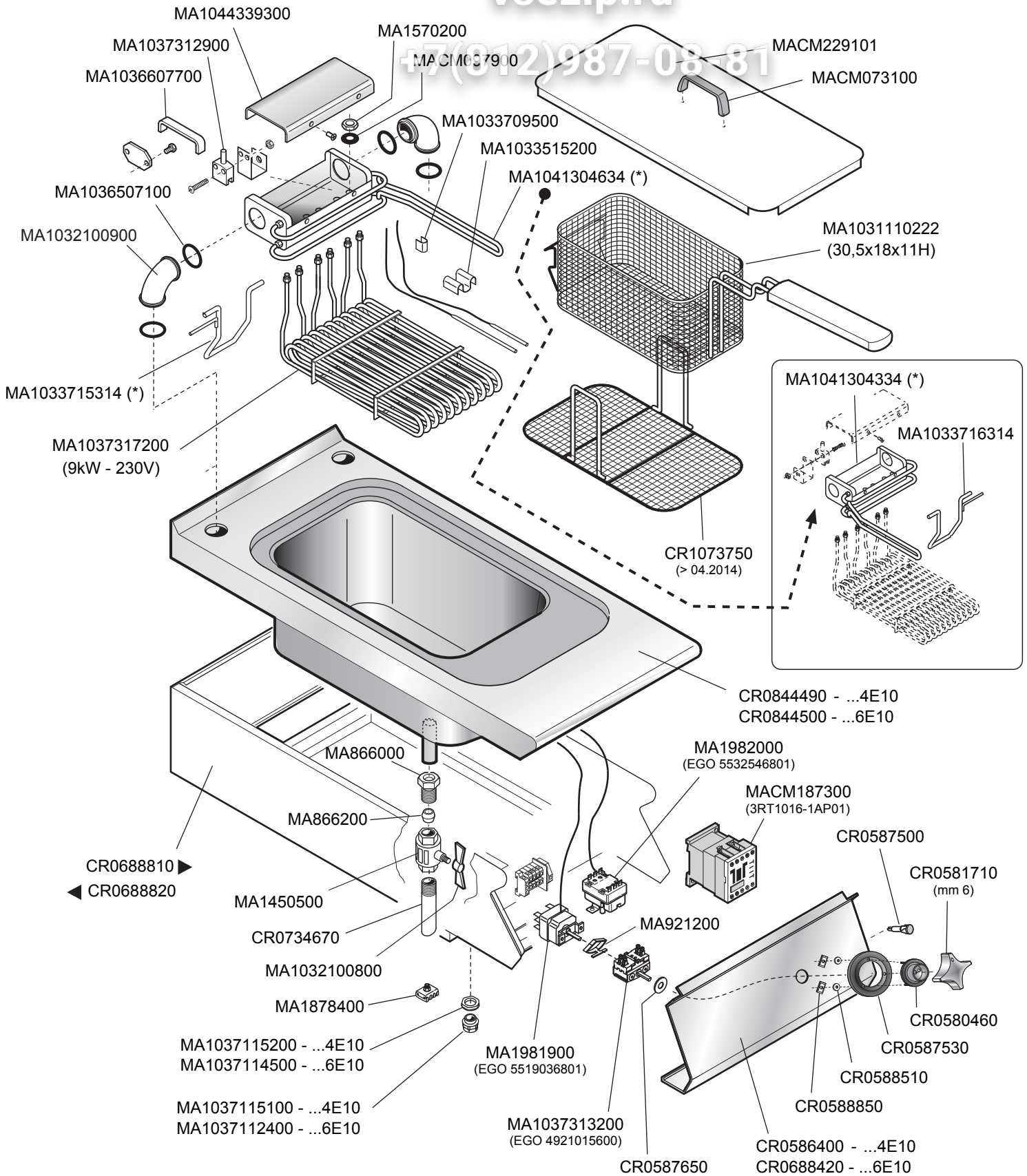

| | | | | | | |
|--|-------------|-------------|------------------------------|--------------------------------------|------|--------------|
|  MARENO INDUSTRIE ALI spa Mareno di Piave (TV) | ELABORATO: | APPROVATO: | GRUPPO: | DENOMINAZIONE: | | |
| | | | Serie NP70 (Vasche 10 litri) | Impianto elettrico FQE41/61 e mobile | | |
| | DATA: | DATA: | PARTICOLARE: | REV. N. | DEL | DISEGNO N. |
| | 01 Giu 2013 | 01 Giu 2013 | Disegno esploso per ricambi | Z01 | 0414 | 3.P70.44 1/3 |
| SOST. DIS. | | | | | | |

NP70-10

Mod.
NF74E10TW CR0951850
NF76E10TW CR0951860

FRIGGITRICI ELETTRICHE 10+10 LITRI
 ELECTRIC HEATED FRYERS 10+10 LITERS
 FRITEUSES ELECTRIQUES 10+10 LITRES
 ELEKTRO FRITEUSEN 10+10 LITERS

vsezip.ru

+7(812)987-08-81

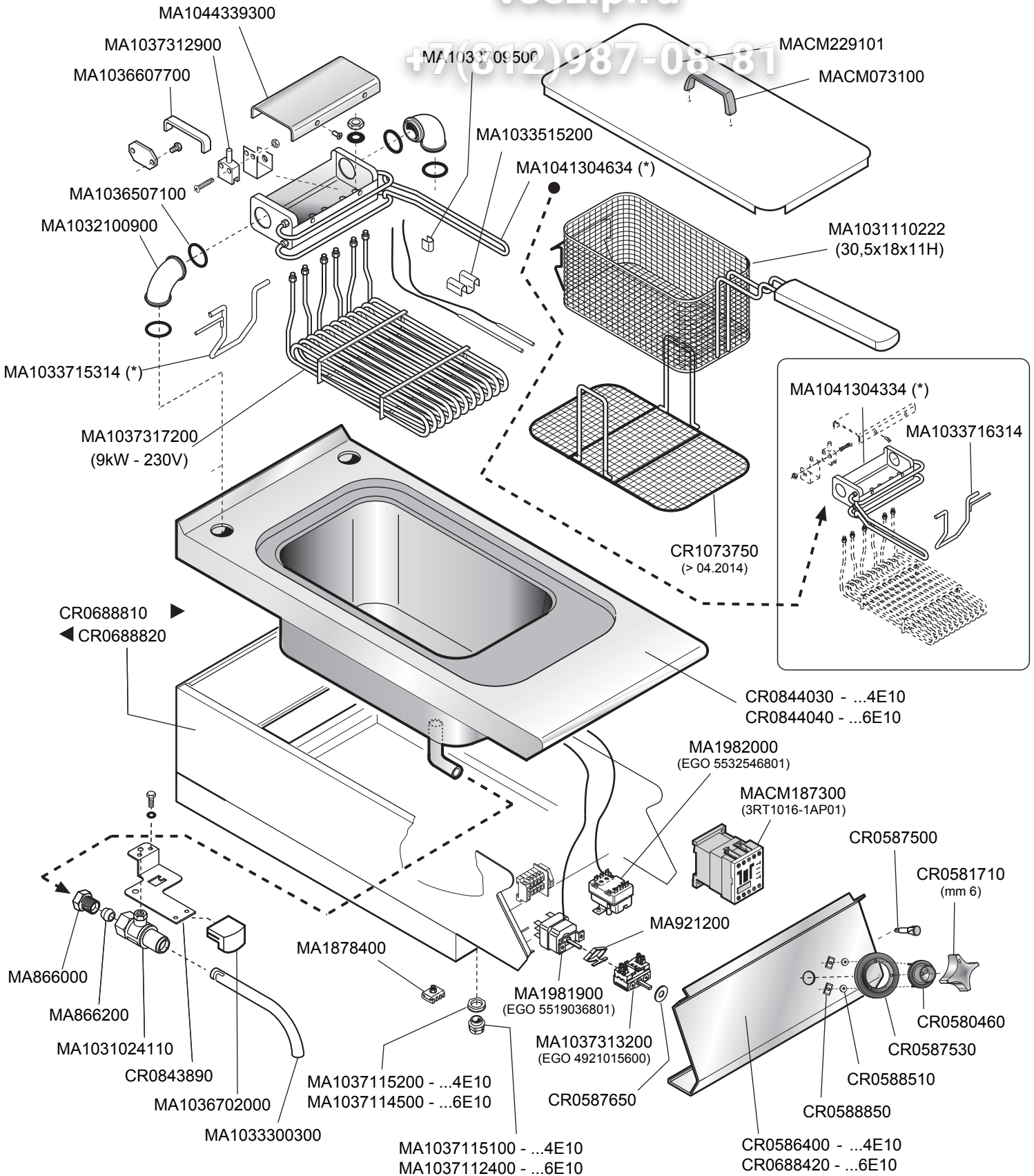

| | | | | | | |
|---|-------------|-------------|------------------------------|----------------------------------|------|---------------|
|  MARENO INDUSTRIE ALI spa Mareno di Piave (TV) | ELABORATO: | APPROVATO: | GRUPPO: | DENOMINAZIONE: | | |
| | | | Serie NP70 (Vasche 10 litri) | Impianto elettrico e mobile W.W. | | |
| | DATA: | DATA: | PARTICOLARE: | REV. N. | DEL | DISEGNO N. |
| | 01 Giu 2013 | 01 Giu 2013 | Disegno esploso per ricambi | Z01 | 0414 | 3.P70W.44 2/3 |
| SOST. DIS. | | | | | | |

NP70-10

Mod.
NF74E10TK CR0851220
NF76E10TK CR0851230
NF74E10TKW CR0851340
NF76E10TKW CR0851350

FRIGGITRICI A COMANDO ELETTRONICO 10+10 LITRI
 ELECTRONIC CONTROL FRYERS 10+10 LITERS
 FRITEUSES ELECTRONIQUES 10+10 LITRES
 ELEKTRO FRITEUSEN 10+10 LITERS

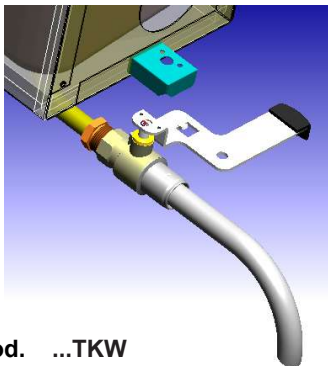
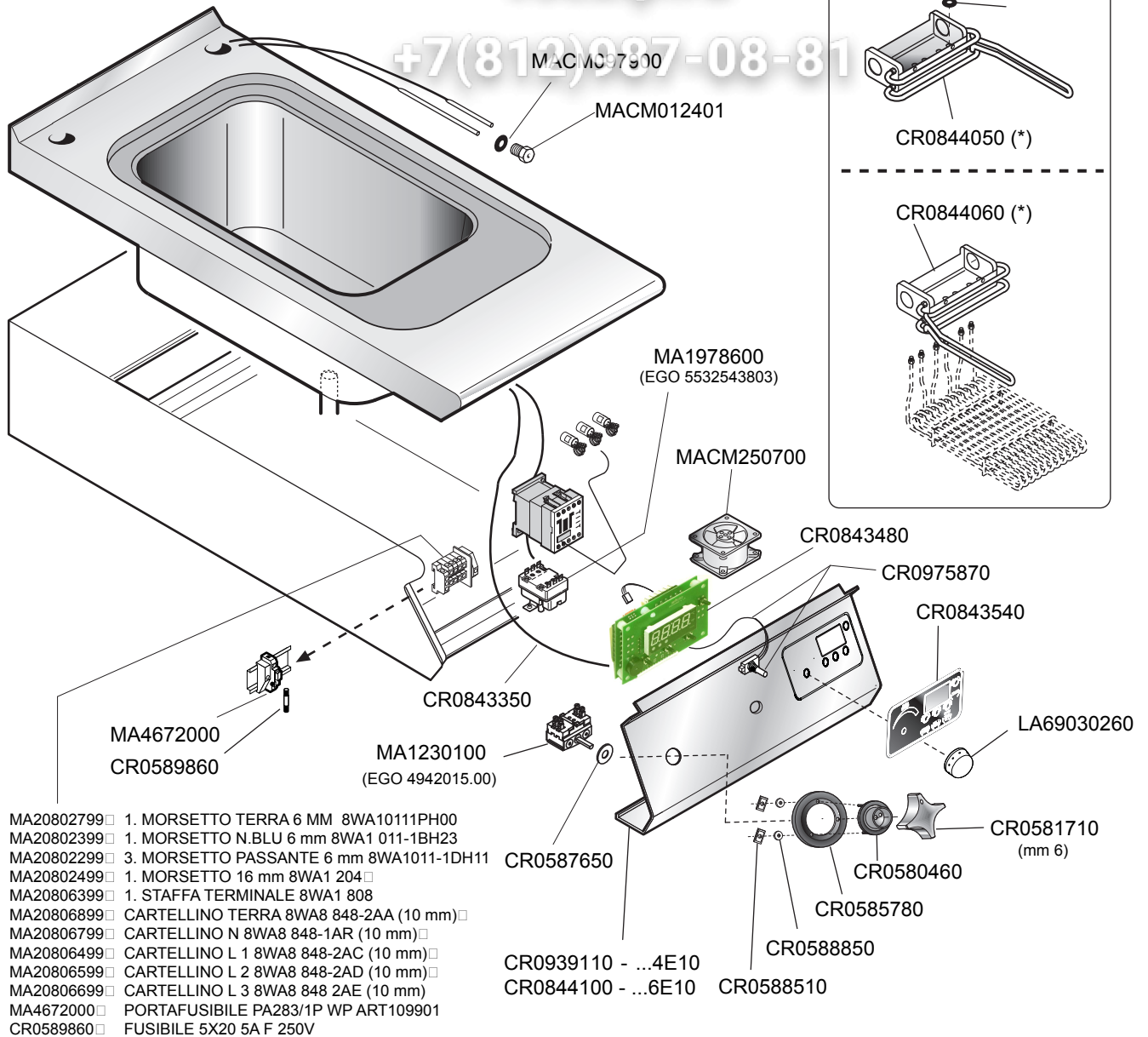

Mod. ...TKW

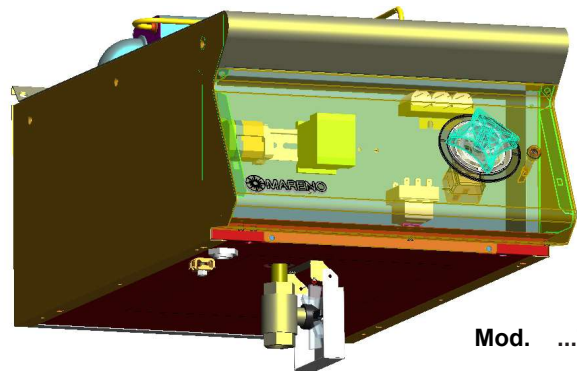

Mod. ...TK

| | | | | | | |
|---|-------------|-------------|------------------------------|---|------|---------------|
|  MARENO INDUSTRIE ALI spa Mareno di Piave (TV) | ELABORATO: | APPROVATO: | GRUPPO: | DENOMINAZIONE: | | |
| | | | Serie NP70 (Vasche 10 litri) | Impianto elettrico e controllo digitale | | |
| | DATA: | DATA: | PARTICOLARE: | REV. N. | DEL | DISEGNO N. |
| | 01 Giu 2013 | 01 Giu 2013 | Disegno esploso per ricambi | Z01 | 0414 | 3.P70K.44 3/3 |
| SOST. DIS. | | | | | | |