

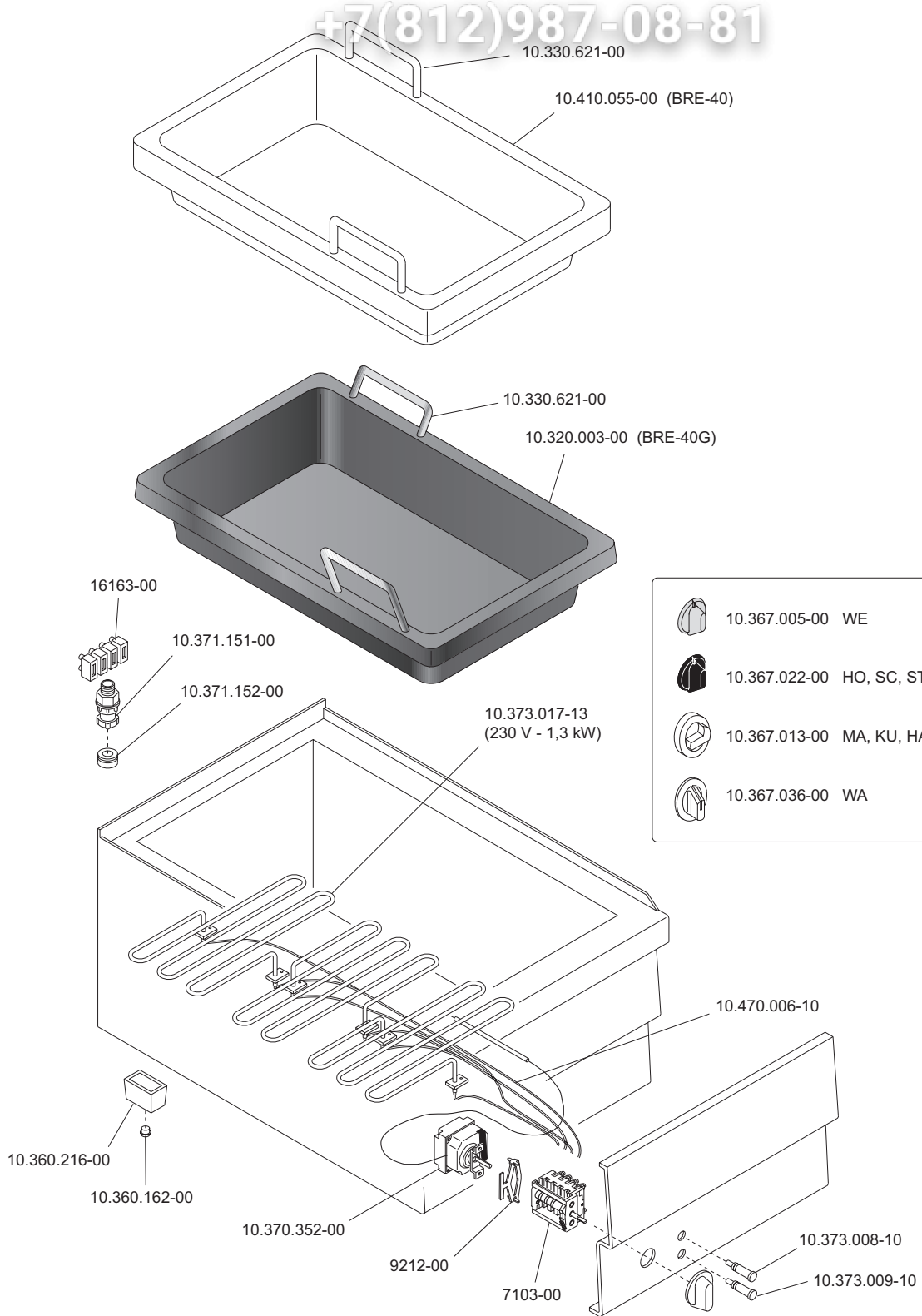

BRE-40
BRE-40G **SERIE 600**

Вип Общежития
vsezip.ru
+7(812)987-08-81

BRASIERE ELETTRICHE
ELECTRIC HEATED BRATT PANS
SAUTEUSES ELECTRIQUES
ELEKTROBEHEIZTE SUDWANNEN
SARTENES ELECTRICAS

BRE-40 10.401.633.10 (M)
BRE-40G 10.401.634.10 (M)



 MARENO INDUSTRIE ALI spa Mareno di Piave (TV)	ELABORATO:	APPROVATO:	GRUPPO:	DENOMINAZIONE:		
	<i>Platt</i>		<i>Serie CE 600 (Snack)</i>	<i>Impianto elettrico e mobile</i>		
	DATA:	DATA:	PARTICOLARE:	REV. N.	DEL	DISEGNO N.
	10 Sett 96	10 Sett 96	<i>Disegno esploso per ricambi</i>	▼	▼	▼
SOST. DIS.	P01 - 9609.3.6.13.BRE		P 0 1 - 9 6 0 9 . 3 . 6 . 1 3 . B R E			

BRE-40 1040163320
BRE-40G 1040163420

BRE-40D 1040242614
BRE-40DB 1040242714
BRE-40DG 1040242814
BRE-40DGB 1040242914

Зип Ощепит

vsezip.ru

+7(812)987-08-81

BRASIERE ELETTRICHE
ELECTRIC HEATED BRATT PANS
SAUTEUSES ELECTRIQUES
ELEKTROBEHEIZTE SUDWANNEN

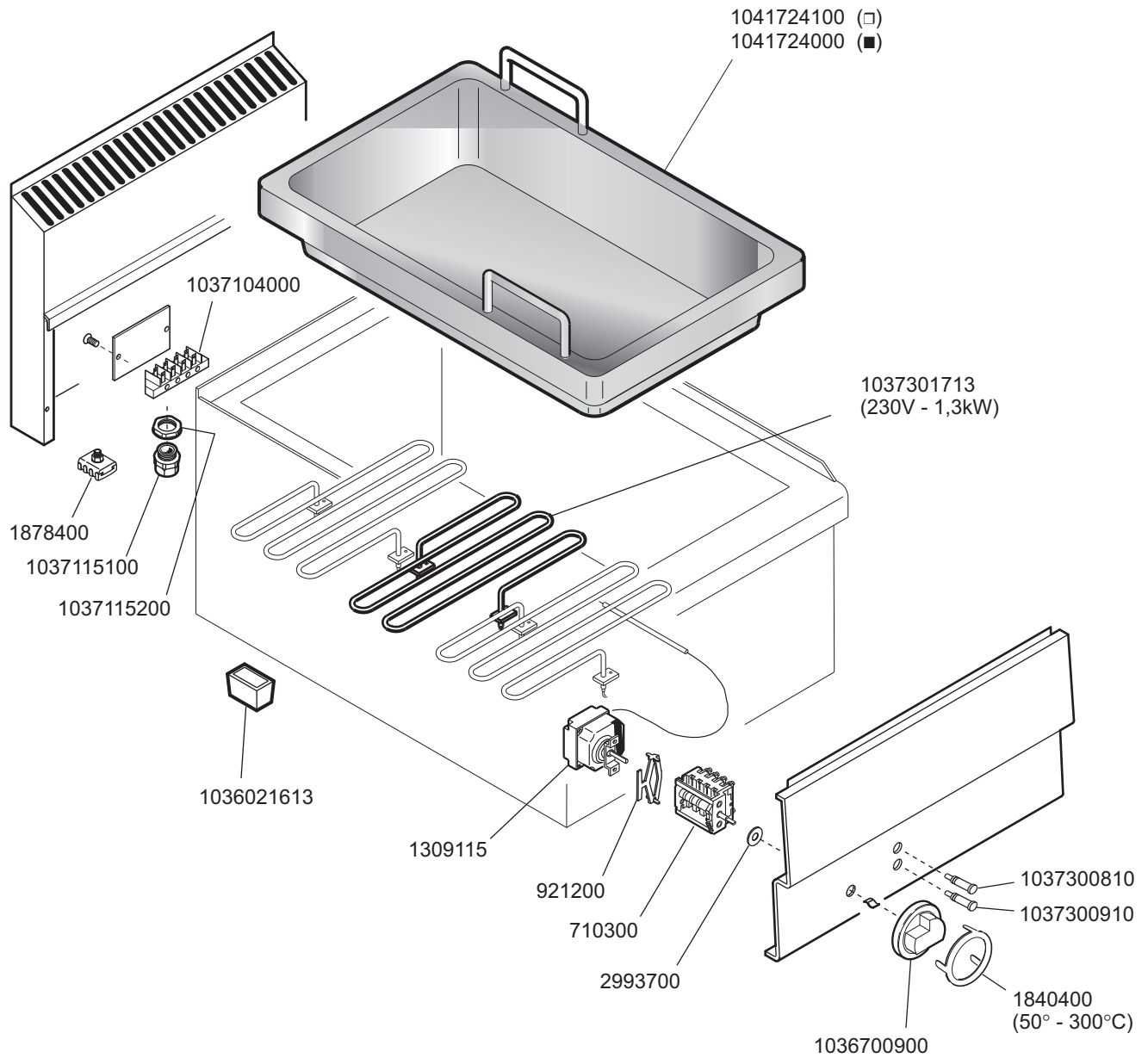

□ (AISI 304) Acciaio Inox - Stainless Steel - Acier Inox - Chromnickelstahl

■ Ghisa - Cast iron - Fonte - Gußeisen

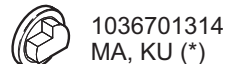
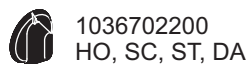
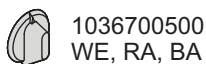

ELABORATO:	APPROVATO:	GRUPPO:	DENOMINAZIONE:		
G.Z.		Serie 600 Snack	Impianto elettrico - Mobile		
DATA:	DATA:	PARTICOLARE:	REV. N.	DEL	DISEGNO N.
10 Gen 1997	10 Gen 1997	Disegno esploso per ricambi	▼	▼	▼
SOST. DIS.	Z00.9701.3.6.45.BRE	CE	Z01	0101	3.6.45.BRE

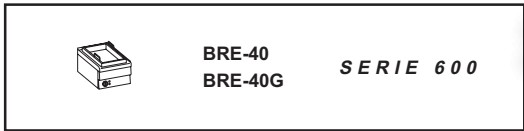

Витр Общепит
vsezip.ru
+7(812)987-08-81

BRASIERE ELETTRICHE
ELECTRIC HEATED BRATT PANS
SAUTEUSES ELECTRIQUES
ELEKTROBEHEIZTE SUDWANNEN
SARTENES ELECTRICAS

BRE-40 10.401.633.20 (M)
BRE-40G 10.401.634.20 (M)

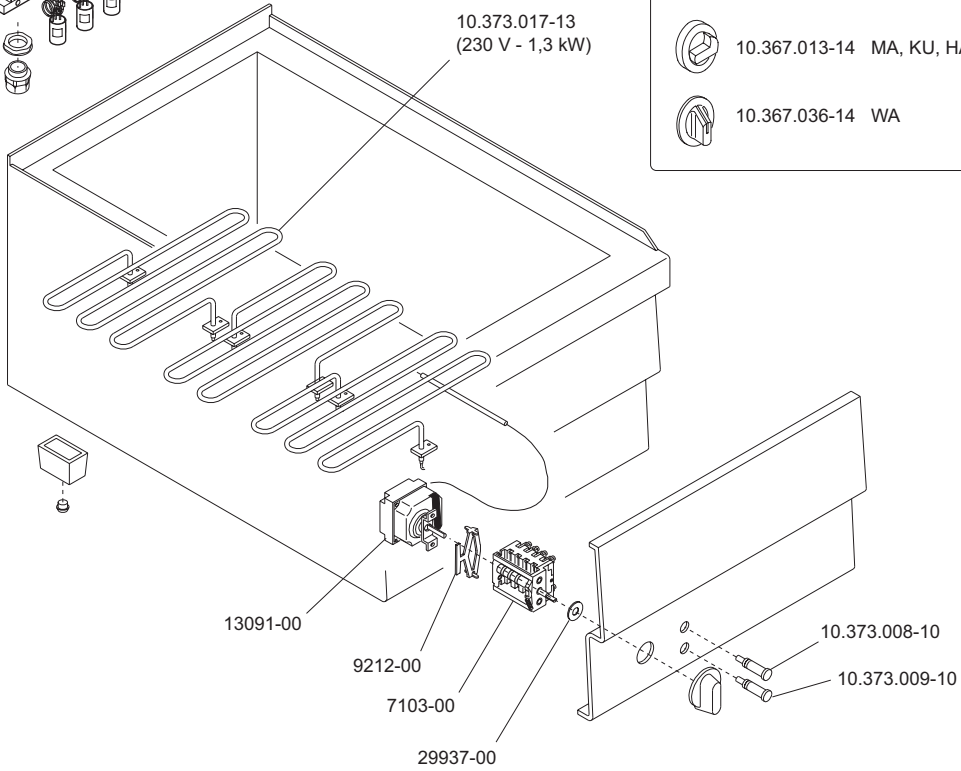
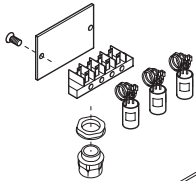
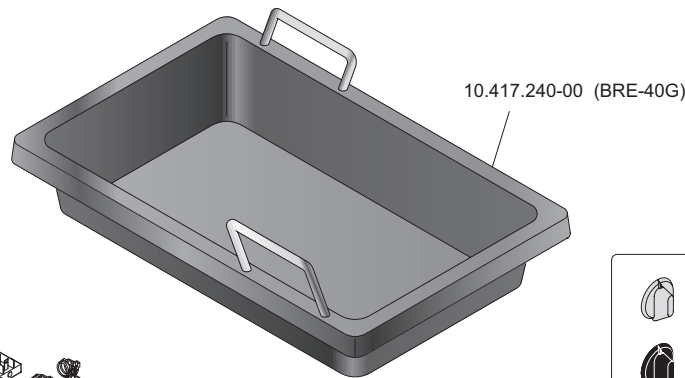
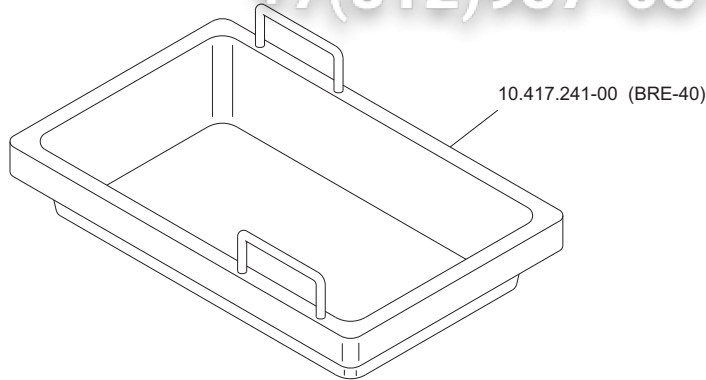

- 10.367.005-00 WE
- 10.367.022-00 HO, SC, ST, DA
- 10.367.013-14 MA, KU, HA
- 10.367.036-14 WA



ELABORATO:	APPROVATO:	GRUPPO:	DENOMINAZIONE:		
<i>Plinetti</i>		Serie CE 600 (snack)	Impianto elettrico e mobile		
DATA:	DATA:	PARTICOLARE:	REV. N.	DEL	DISEGNO N.
10 Gen 97	10 Gen 97	Disegno esplosivo per ricambi	▼	▼	▼
SOST. DIS. Z00 - 9701.3.6.45.BRE			Z00 - 9701.3.6.45.BRE		

BRE-40 1040163320 (OBRE-40)
BRE-40G 1040163420

BRE-40D 1040242614
BRE-40DB 1040242714
BRE-40DG 1040242814
BRE-40DGB 1040242914

Зип Общепит

vsezip.ru

+7(812)987-08-81

BRASIERE ELETTRICHE
ELECTRIC HEATED BRATT PANS
SAUTEUSES ELECTRIQUES
ELEKTROBEHEIZTE SUDWANNEN

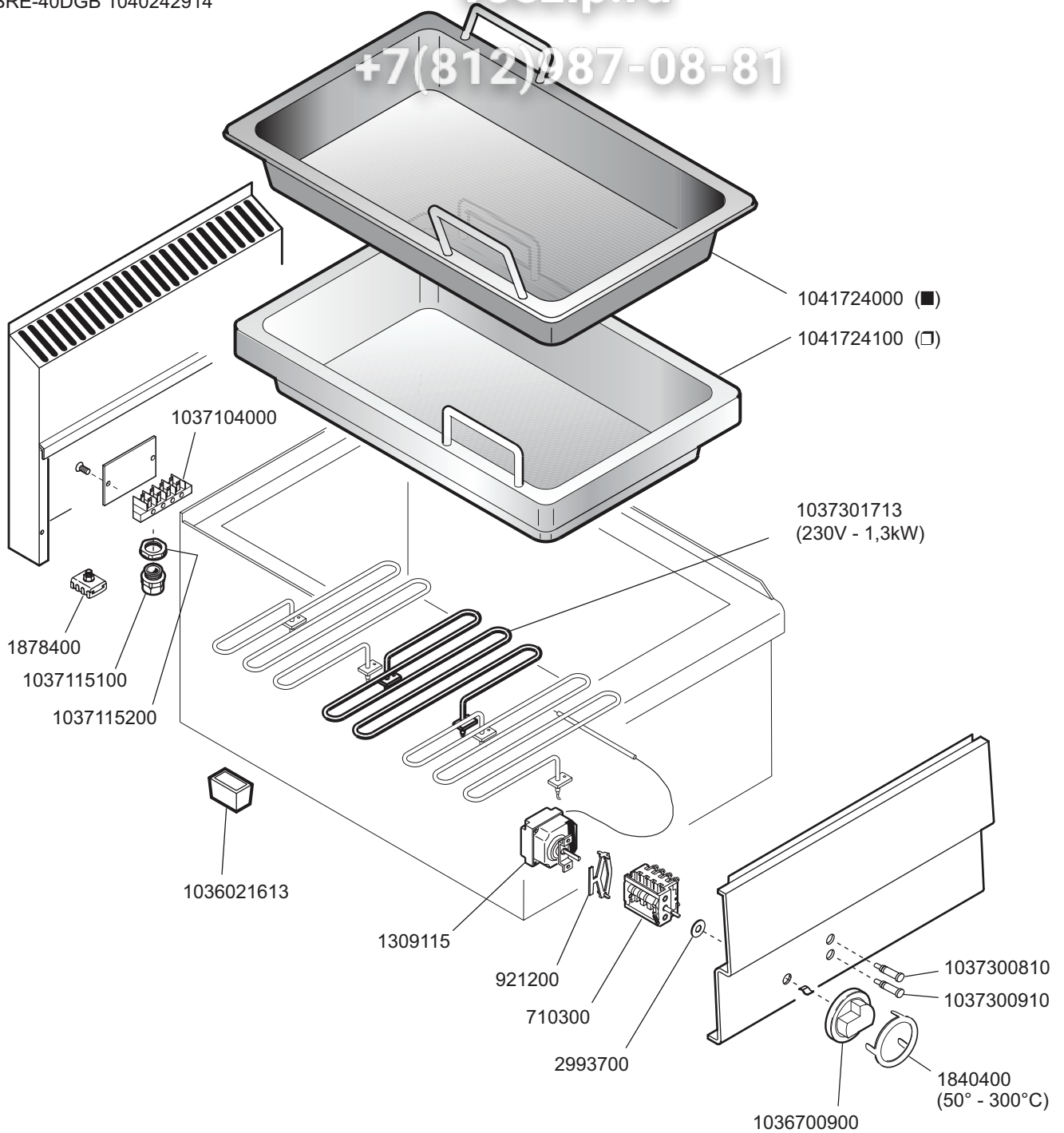

□ (AISI 304) Acciaio Inox - Stainless Steel - Acier Inox - Chromnickelstahl

■ Ghisa - Cast iron - Fonte - Gußeisen



CR0502140 (Metos)
CR0502140 (Bartscher)
CM188200 (Franke)



1036700500
WE, RA, BA



1036702200
HO, SC, ST, DA



1036701314
MA, KU (*)



1036703614
WA

<p>MARENO INDUSTRIES ALI spa^{pa} Mareno di Piave (TV)</p>	ELABORATO:	APPROVATO:	GRUPPO:	DENOMINAZIONE:		
	G.Z.		Serie 600 Snack	Impianto elettrico - Mobile		
	DATA:	DATA:	PARTICOLARE:	REV. N.	DEL	DISEGNO N.
	10 Gen 1997	10 Gen 1997	Disegno esploso per ricambi	Z01	0106	3.6.45
SOST. DIS.	Z00.9701.3.6.45.BRE		CE			