

Зип Общепит



vsezip.ru

+7(812)987-08-81



FM-300 U

Spare Parts
Pièces Détachées
Ersatzteile
Onderdelen

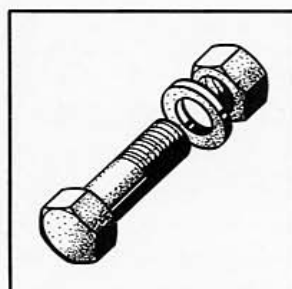

+7(812)987-08-81

Tank and panels	page 3
Door	page 4
Water inlet	page 5
Anti-siphon-device	page 6
Booster	page 7
Wash and rinse system	page 8
Wash pump	page 9
Drain and strainers	page 10
Drain pump	page 11
Rinse booster pump	page 12
Control box	page 13
Rinse agent dispenser	page 14
Detergent dispenser	page 15
Extension for 900 mm height	page 16
Supporting frame	page 17

Sommaire

Bac et panneaux	page 3
Porte	page 4
Arrivée d'eau	page 5
Brise-vide	page 6
Chaudière	page 7
Système de lavage et de rinçage	page 8
Pompe de lavage	page 9
Vidange et filtres	page 10
Pompe de vidange	page 11
Pompe élévatrice de pression	page 12
Coffret électrique	page 13
Doseur de produit lessiviel	page 14
Doseur de produit détergent	page 15
Socle pour 900 mm hauteur	page 16
Bâti inférieur	page 17

Inhaltsverzeichnis

Tank und Verkleidungen	Seite 3
Tür	Seite 4
Eingangsleitung	Seite 5
Rücksaugverhinderer	Seite 6
Boiler	Seite 7
Wasch- und Spülsystem	Seite 8
Waschpumpe	Seite 9
Ablauf und Siebe	Seite 10
Ablaufpumpe	Seite 11
Drucksteigerungspumpe	Seite 12
Schaltkasten	Seite 13
Netzmittel-Dosiergerät	Seite 14
Waschmittel-Dosiergerät	Seite 15
Sockel für 900 mm Höhe	Seite 16
Untergestell	Seite 17

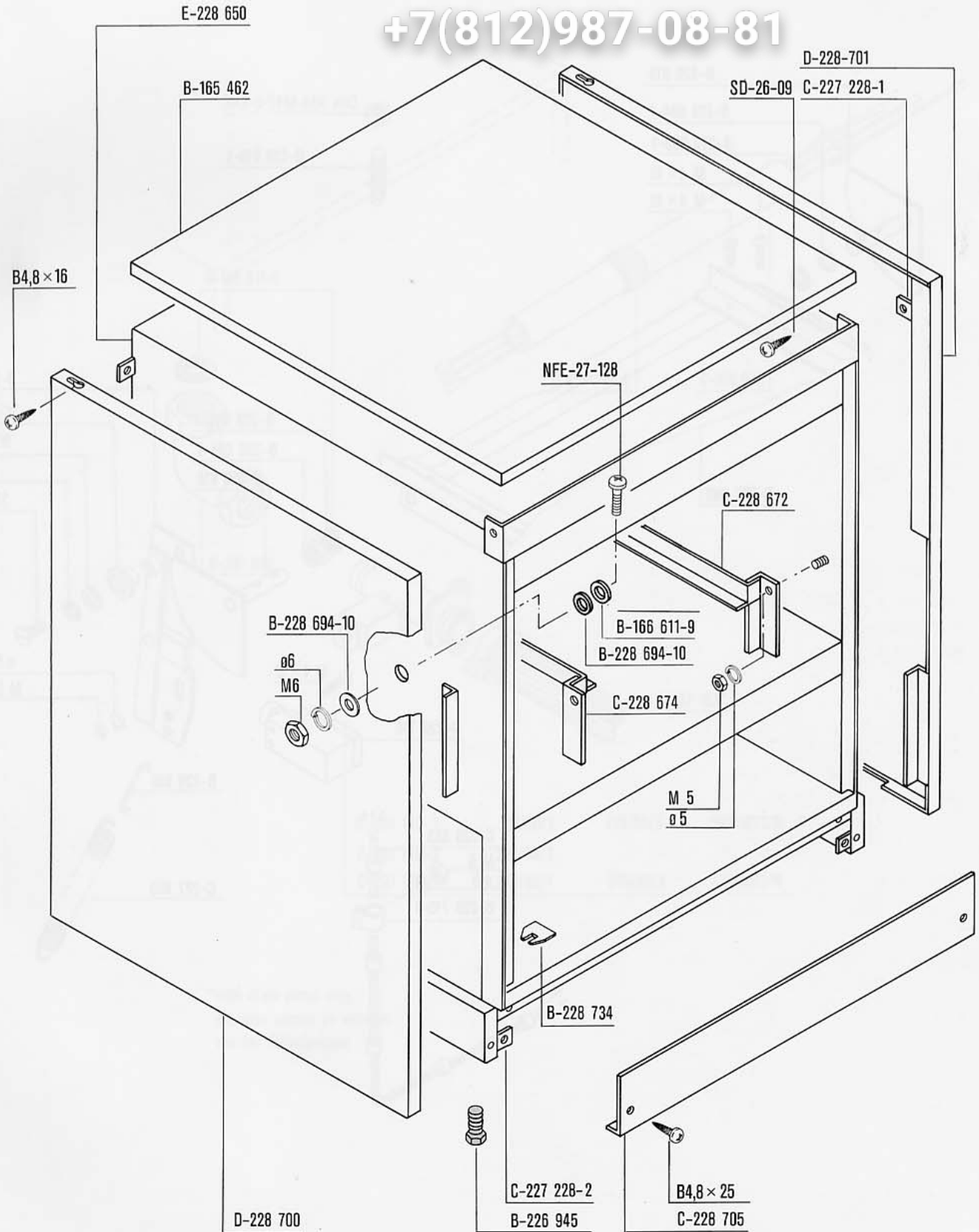

vsezip.ru

+7(812)987-08-81

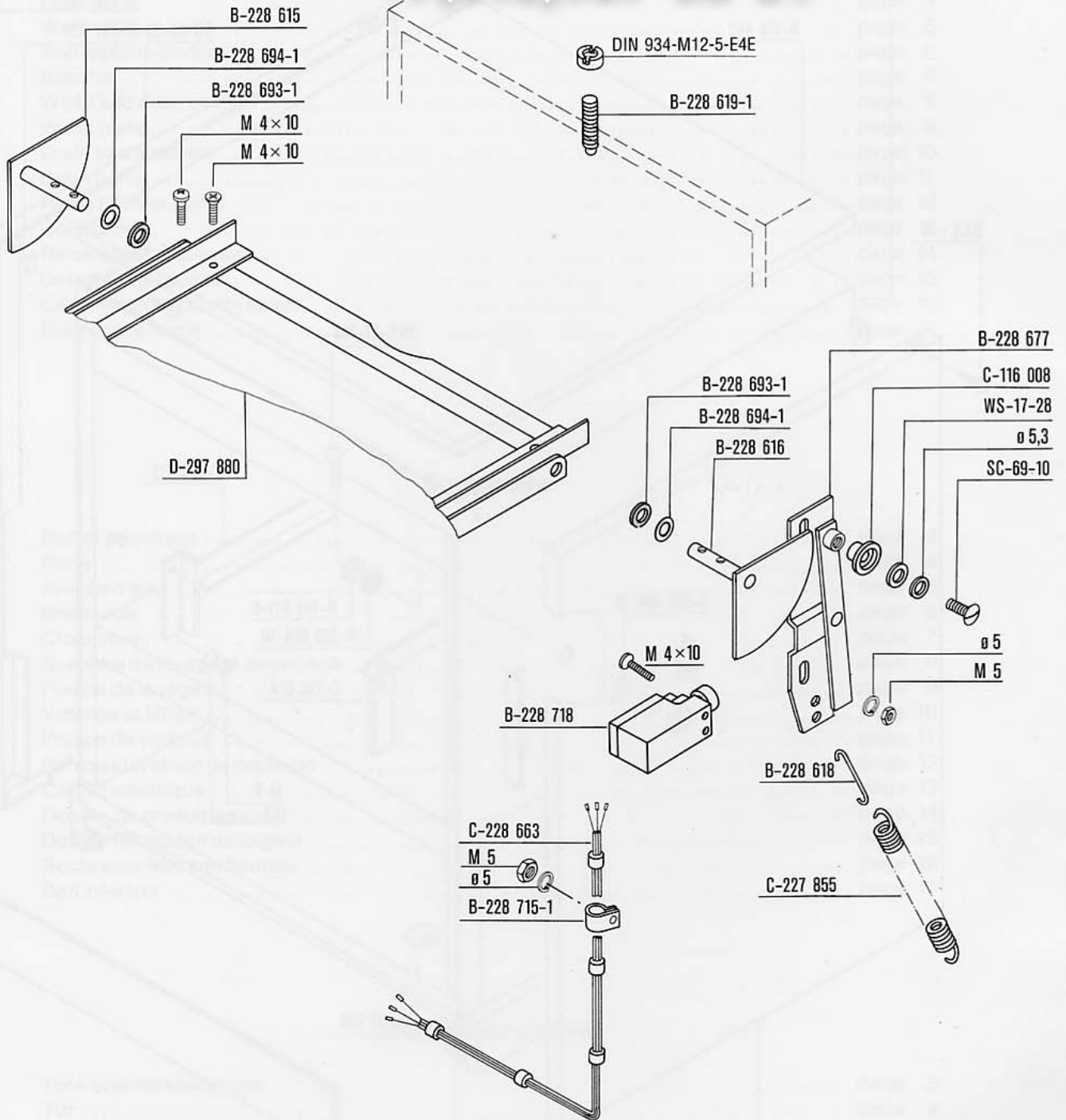

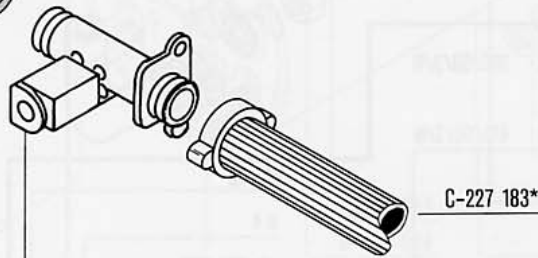
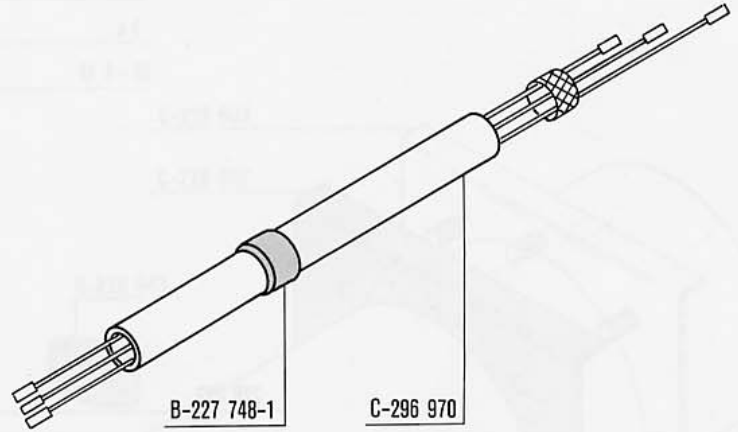

C-297 808-1	220/50/1	220/50/3	380/50/3/N
C-297 808-2	220/60/3		
C-297 808-3	240/50/1	240/50/3	415/50/3/N

*with drain pump only
slit. avec pompe de vidange
nur bei Ablaufpumpe

Зип Общепит

vsezip.ru

+7(812)987-08-81

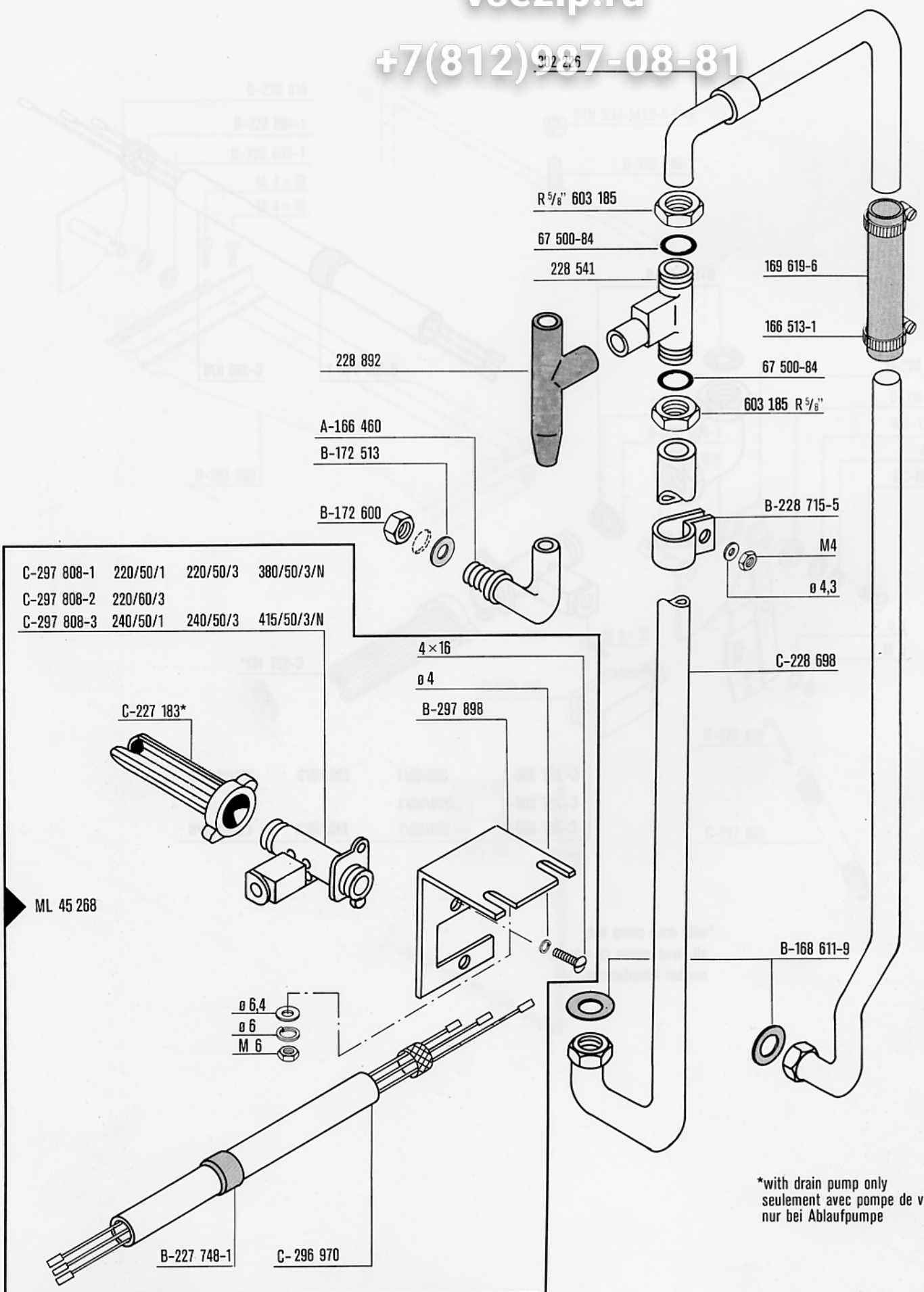

*with drain pump only
 seulement avec pompe de vidange
 nur bei Ablaufpumpe

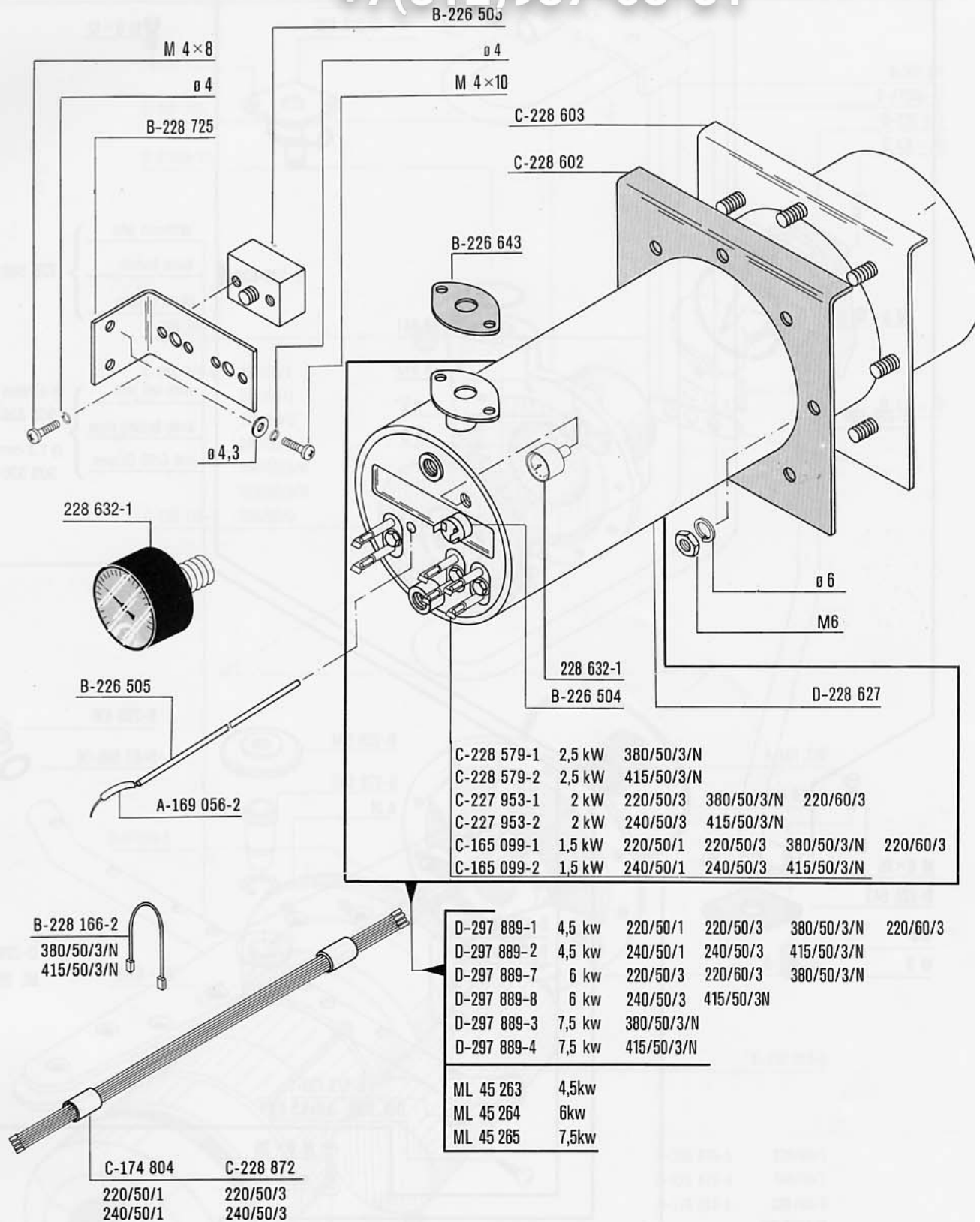

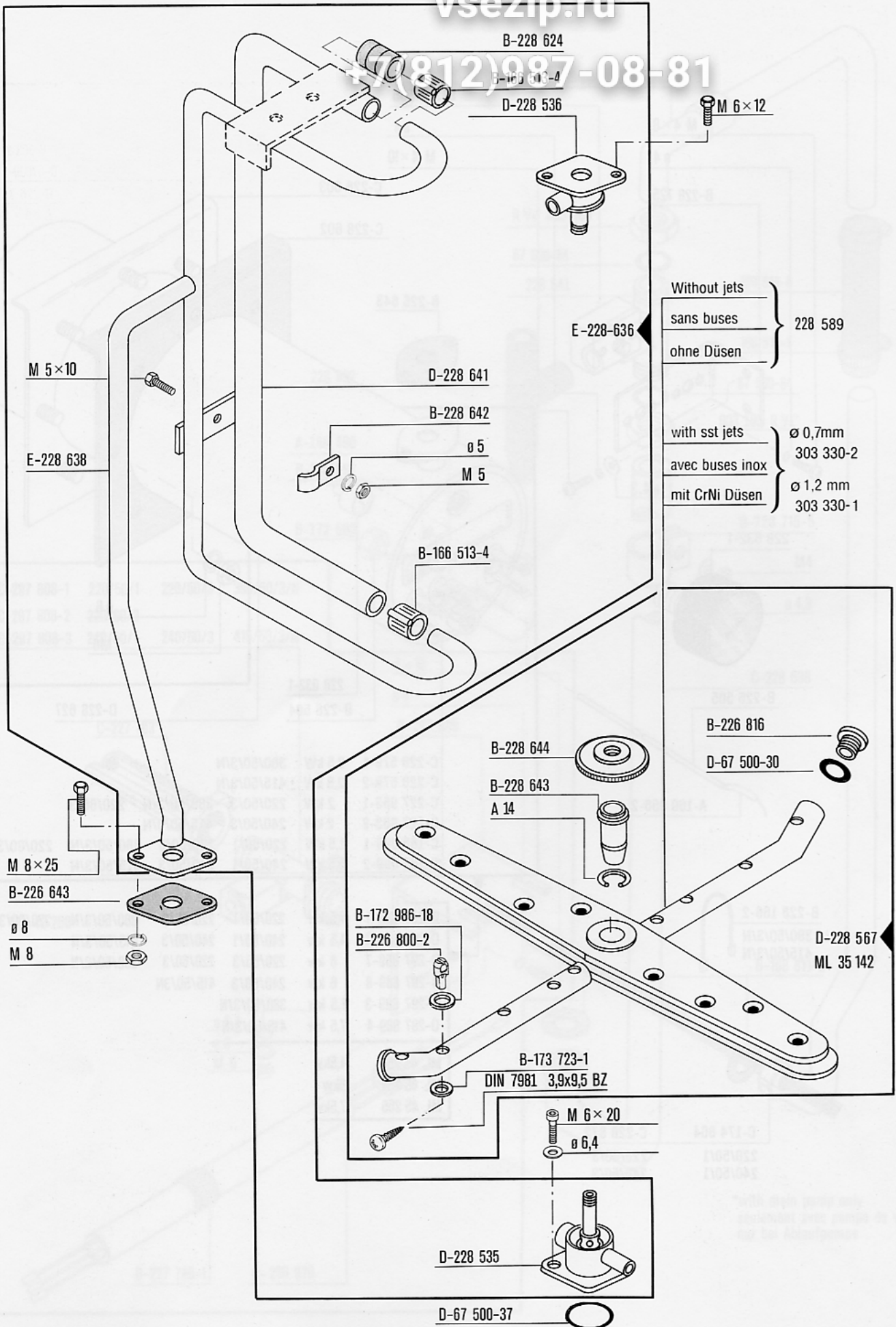

D-226 776-1 220/50/1
 D-226 776-2 240/50/1
 D-226 776-3 220-380/50/3/N

D-226 776-4 240-415/50/3/N
 D-226 776-6 220/60/3

+7(812)987-08-81

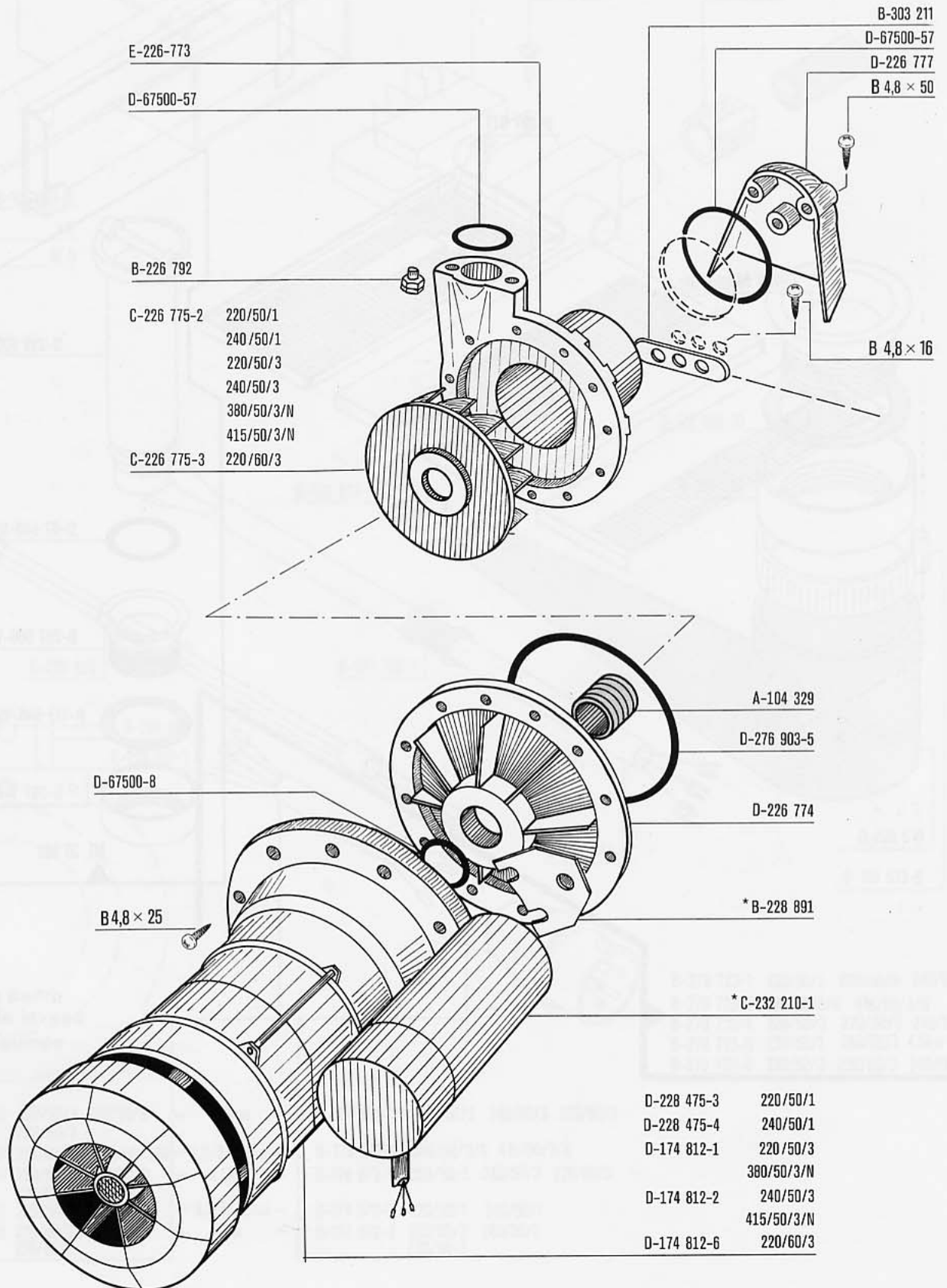

vsezip.ru

+7(812)987-08-81

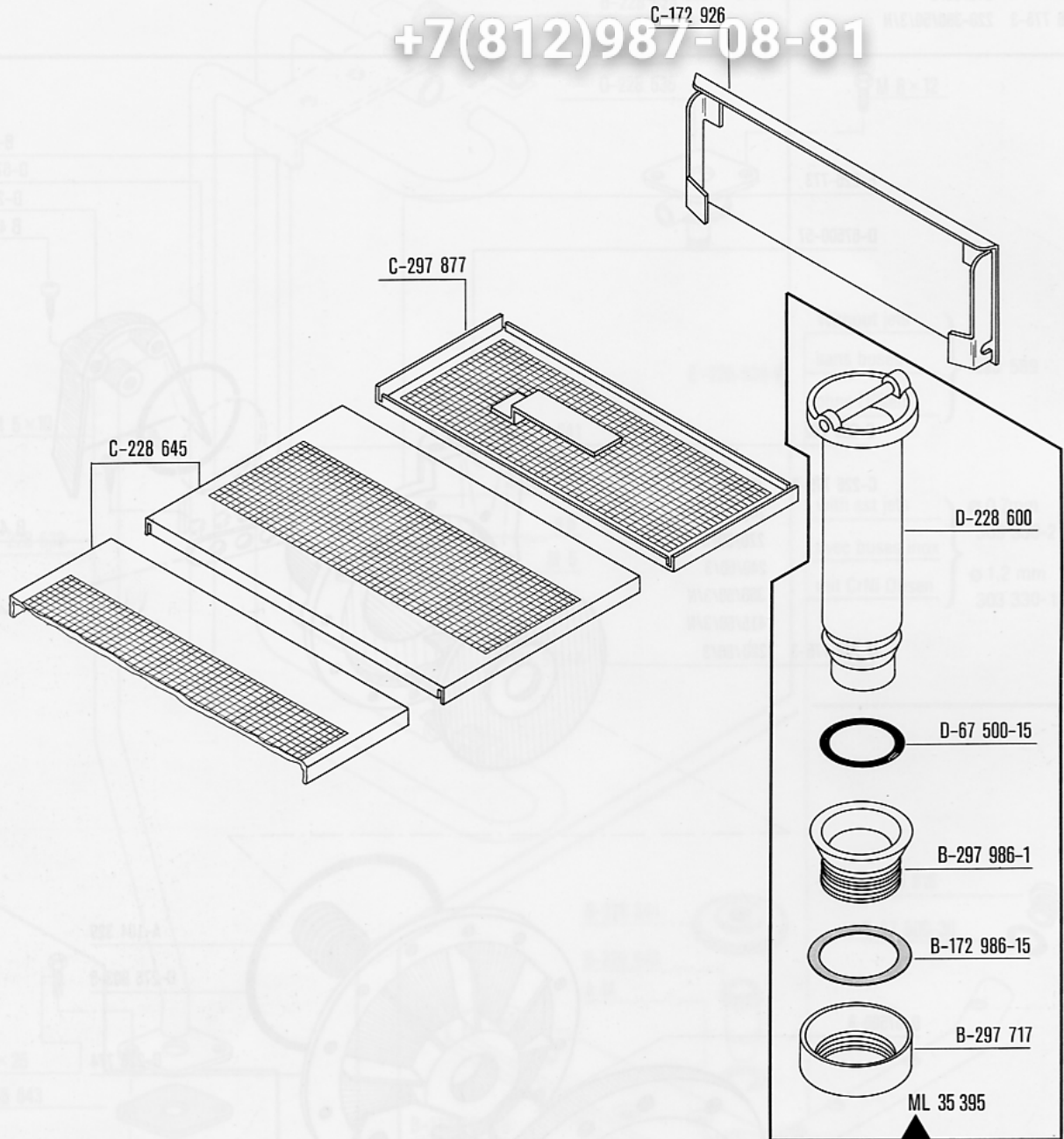

vsezip.ru

C-228 923

+7(812)987-08-81

D-165 653-1

M 6 x 16

C-228 751

B-166 513-1

B-168 611-4

ø 5

M 5

B-297 986-2

B-172 986-15

B-297 717

B-166 513-1

B-227 748-1

C-228 920

B-228 925

C-228 917-1

C-228 744

C-228 919

B-166 513-9

B-279 723-1	220/50/3	220/60/3	240/50/3	7,5kw
B-279 723-2	380/50/3/N	415/50/3/N		
B-279 723-4	220/50/3	220/60/3	240/50/3	4,5kw
B-279 723-5	220/50/1	240/50/1	4,5kw 6kw 7,5kw	
B-279 723-6	220/50/3	220/60/3	240/50/3	6kw

Wash pump
Pompe de lavage
Waschpumpe

B-174 811	220/50/3	240/50/3	220/60/3	7,5kw	B-174 972-2	220/50/3	240/50/3	220/60/3
B-174 810	380/50/3/N	415/50/3/N		4,5/6/7,5kw	B-174 972-1	380/50/3/N	415/50/3/N	
B-174 809	220/50/3	240/50/3	220/60/3	4,5kw	B-174 972-1	220/50/3	240/50/3	220/60/3
B-174 807	220/50/1	240/50/1		4,5/6/7,5kw	B-174 972-2	220/50/1	240/50/1	
B-174 808	220/50/3	240/50/3	220/60/3	6kw	B-174 972-2	220/50/3	240/50/3	220/60/3

+7(812)987-08-81

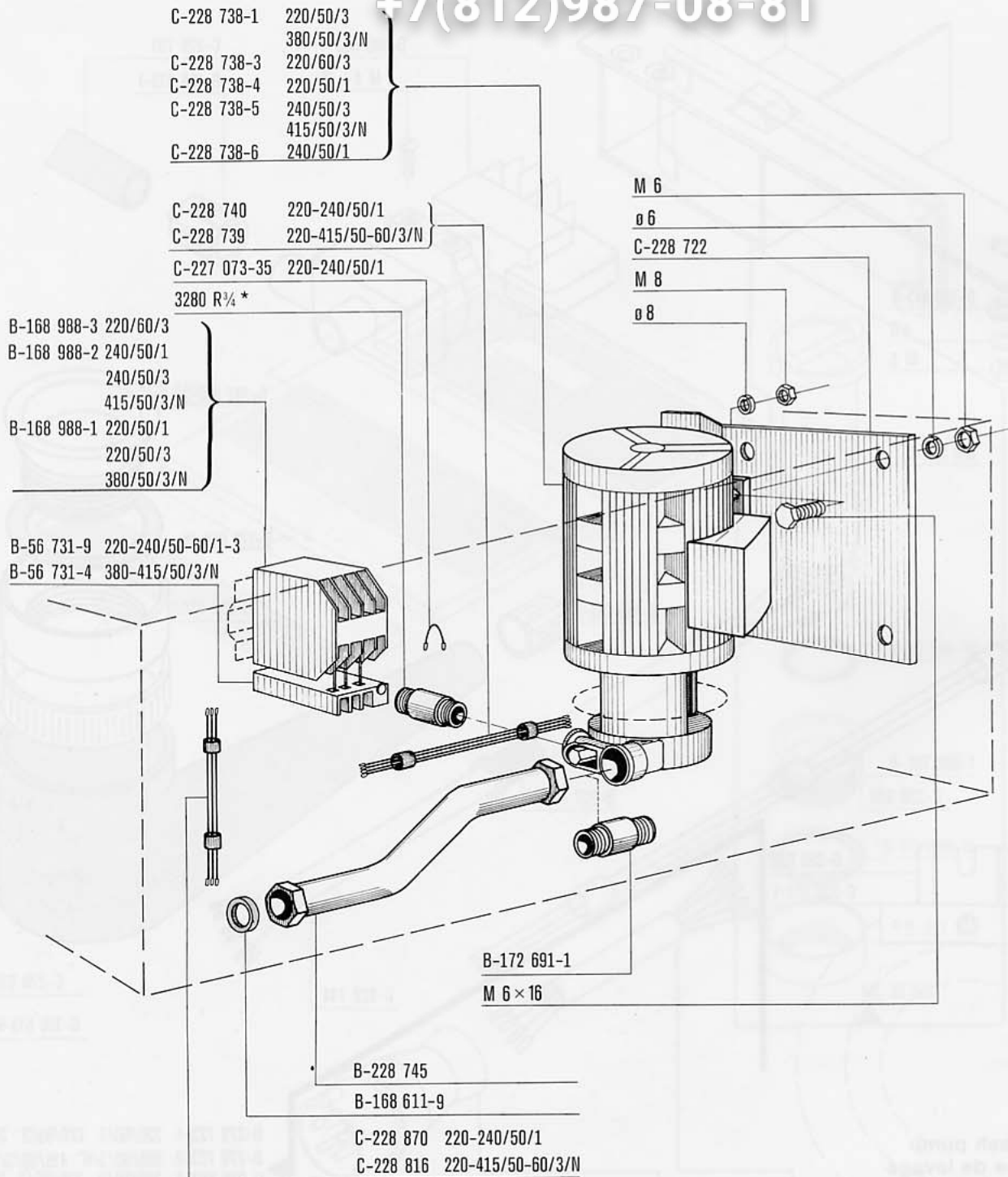

* with drain pump only
 slt. avec pompe de vidange
 nur bei Ablaufpumpe

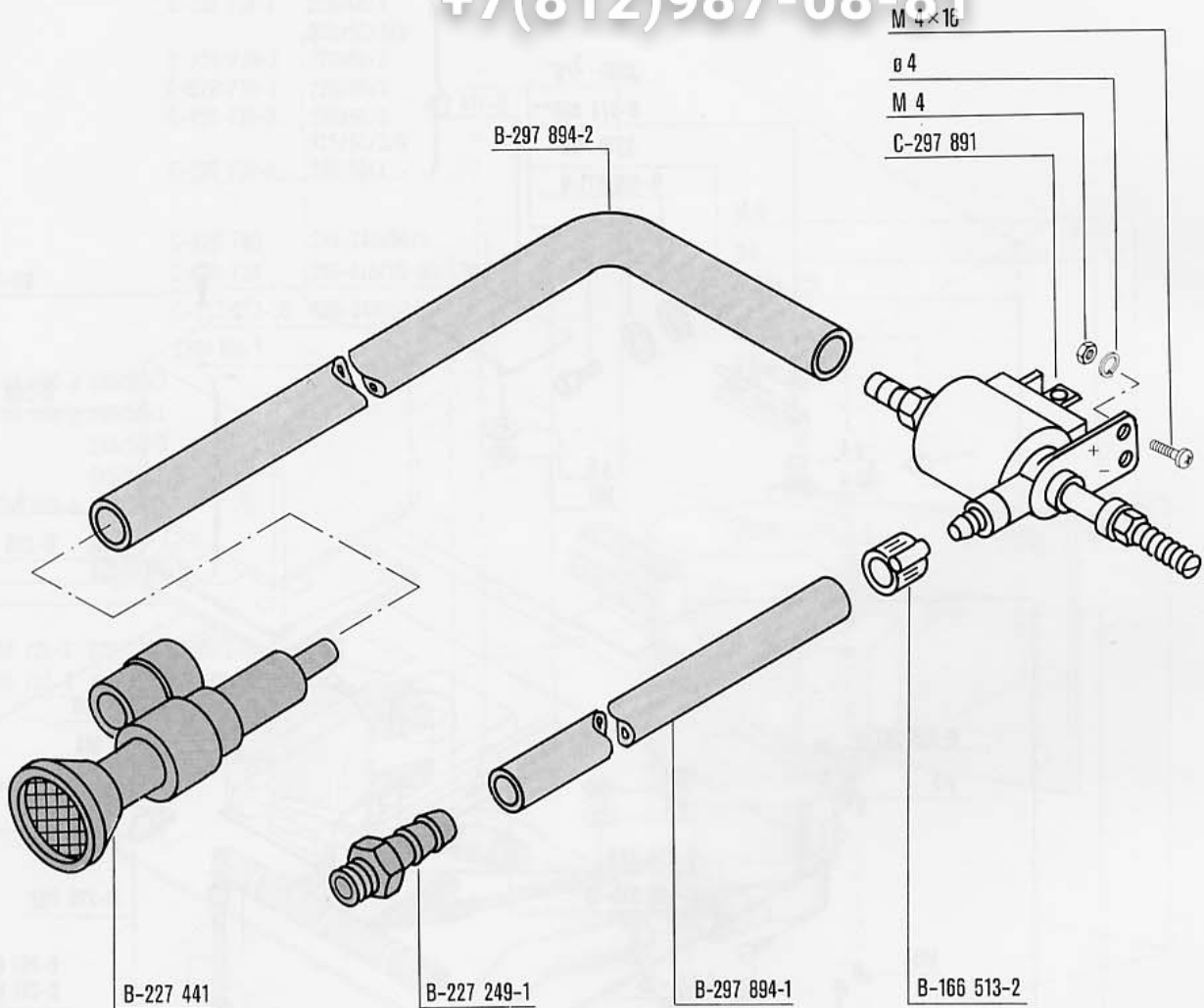

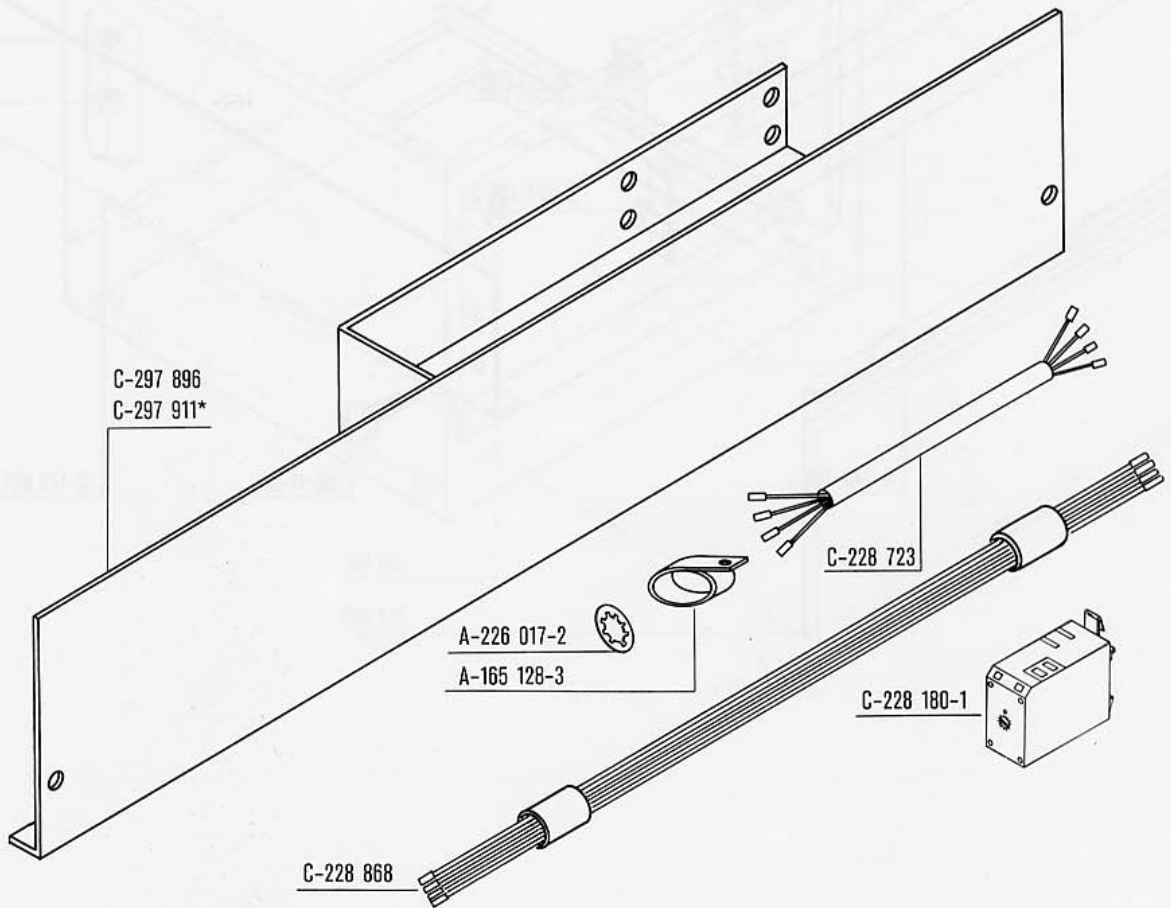

*900 mm machine height
 900 mm hauteur de la machine
 900 mm Maschinenhöhe

Зип Общепит

vsezip.ru

+7(812)987-08-81

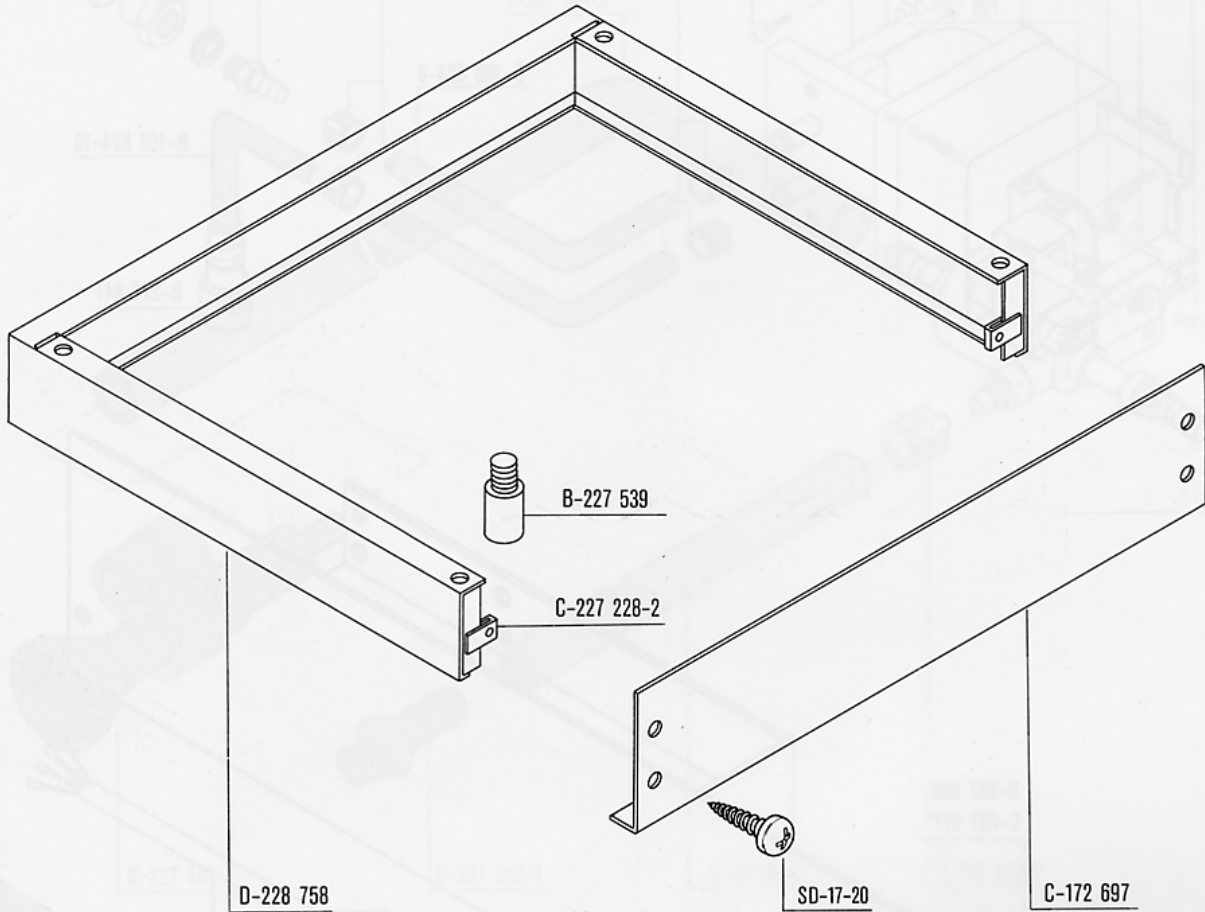







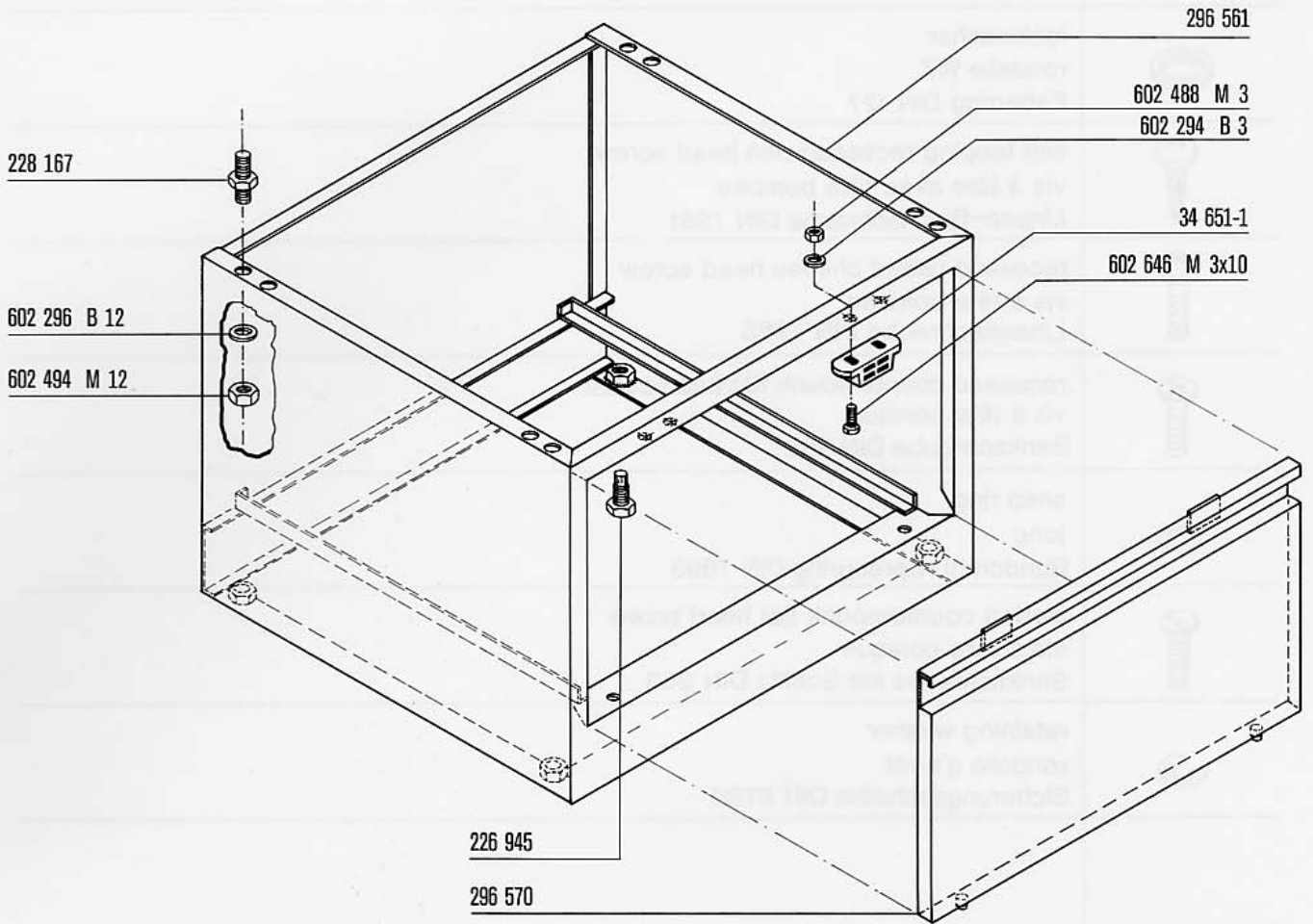



Зип Общепит

vsezip.ru

+7(812)987-08-81



part pièces Teile	part name nom de la pièce Teile-Benennung
	hexagon head screw vis H Sechskantschraube DIN 933
	hexagon nut écrou H Sechskantmutter DIN 934
	washer rondelle Scheibe DIN 125
	lockwasher rondelle WZ Federring DIN 127
	self tapping recessed pan head screw vis à tôle avec tête bombée Linsen-Blechschaube DIN 7981
	recessed raised cheese head screw vis à tête bombée Linsenschraube DIN 7985
	recessed countersunk flat head screw vis à tête conique Senkschraube DIN 965
	snap ring jonc Runddraht-Sprengring DIN 7993
	slotted countersunk flat head screw vis à tête conique Senkschraube mit Schlitz DIN 963
	retaining washer rondelle d'arrêt Sicherungsscheibe DIN 6799