

Зип Общепит

vsezip.ru

DESPIECE TECNICO

+7(812)987-08-81

Cocinas eléctricas
Electric ranges
Fourneaux électriques
Elektro-herde
Cucine elettriche
Fogões elétricos

GAMA 700

Modelos:

CE7-20

CE7-40

CE7-41

Mayo 2008 May

Revisado Mayo 2014 May Revised

FAGOR 

FAGOR INDUSTRIAL

Зип Общепит

vsezip.ru

+7(812)987-08-81

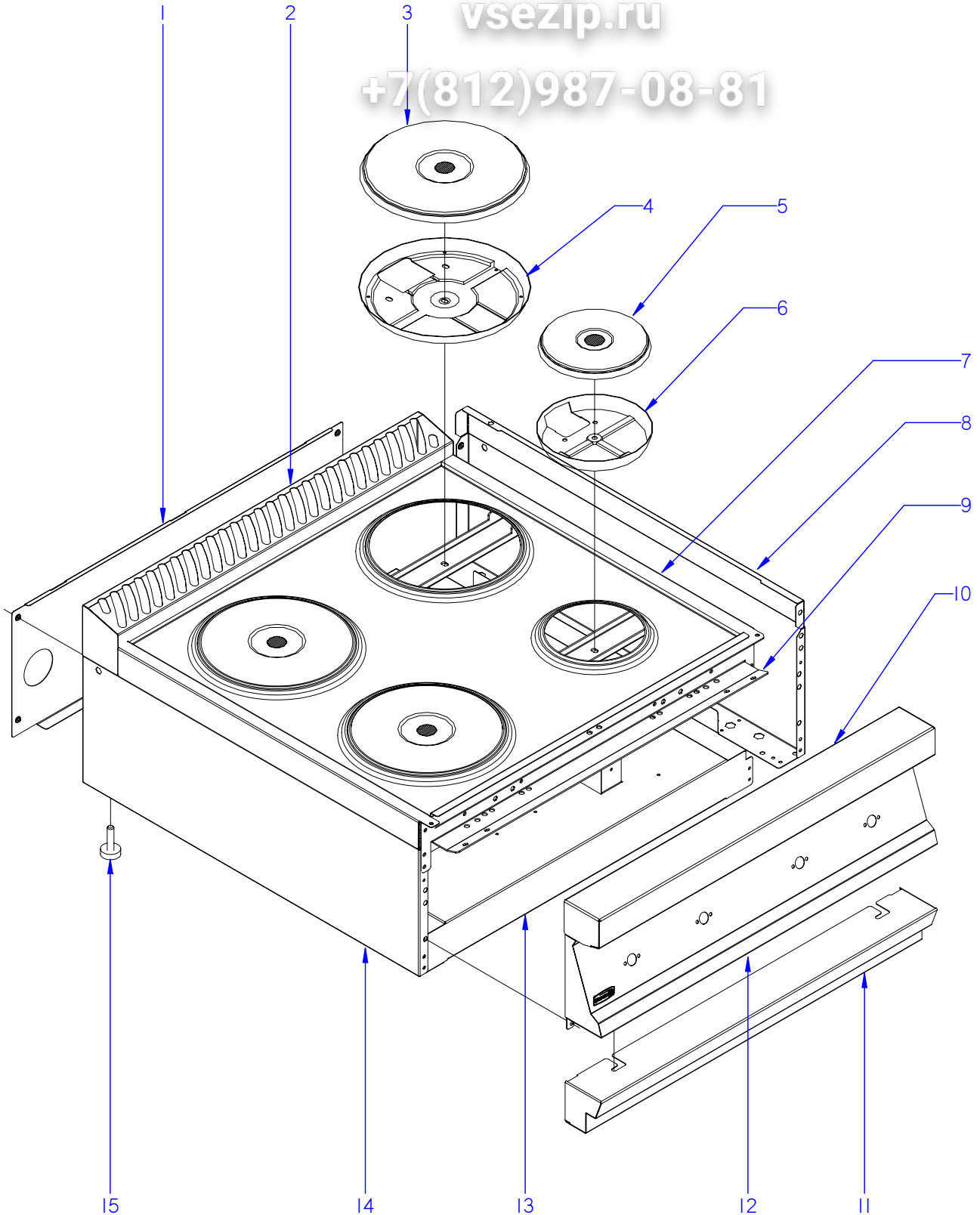

ITEM MARCADO EN COLOR = REPUESTO RECOMENDADO
COLOURED ITEM = RECOMMENDED SPARE PART

N plano	Firma	Fecha	Aparato	MUEBLE	Lamina	Fagor Industrial S.Coop. FAGOR
C-2040	<i>[Signature]</i>	2008-05	COCINA CE7-20 / CE7-40		1	Oñate

MOD.		COCINAS		ZONA		MUEBLE			
ITEM	CODIGO	DENOMINACION	TEXTO	CE7-20	CE7-40				
1	H602804000	PANEL POSTERIOR SU. G700 1/2M	SUP REAR PANEL G700 1/2M	1	_				
1	H602808000	PANEL POSTERIOR SUP. G700 1M	SUP REAR PANEL G700 1M	_	1				
	Q419005000	REMACHE 4X8 ALMG3 / ALUMINIO	RIVET 4X8 ALMG3 / ALUMINIUM	4	4				
	X010503000	CIERRE MUELLE	LOCK SPRING	3	4				
	Q419007000	REMACHE TUBULAR C/V D3.2X6	TUBULAR RIVET C/V D3.2X6	6	8				
2	H125404000	EMBELLECEDOR POSTERIO. 1/2M	REAR TRIM. 1/2M	1	_				
2	S565401000	EMBELLECEDOR POSTERIOR 1M	REAR TRIM 1M	_	1				
3	U803000000	PLACA PUNTO ROJO 2600W-230V	RED POINT PLATE 2600W-230V	2	3				
4	U793030000	CAZOLETA	CASING	2	3				
5	U803002000	PLACA PUNTO ROJO 1500W-230V	RED POINT PLATE 1500W-230V	_	1				
6	U793031000	CAZOLETA 1500W.ULGOR C79A001	CASING 1500W.ULGOR C79A001	_	1				
	Z608410000	CASQUILLO AMARRE TECLADO	KEYBOARD ANCHORAGE BUSH	2	4				
	Q162040000	TUERCA EXAGONAL M6	HEXAGONAL NUT M6	2	4				
	Q302022000	ARANDELA 16X6X1.2 A.304	WASHER 16X6X1.2 A.304	2	4				
7	U952807000	MESA 1/2M (CE7-20)	BENCH 1/2M (CE7-20)	1	_				
7	U955401000	MESA 1M (CE7-41)	BENCH 1M (CE7-41)	_	1				
	Q012031000	TORNILLO EXAGONAL M5X10 A.304	HEXAGONAL BOLT M5X10 A.304	4	4				
8	H122802000	PANEL LATERAL SUP. DCHO. G700	RIGHT SUP. SIDE PANEL G700	1	1				
	Q221342000	REMACHE EXAGONAL M5	HEXAGONAL RIVET M5	5	5				
	Q221343000	REMACHE EXAGONAL M6	HEXAGONAL RIVET M6	5	5				
9	H602602000	ESCUADRA AMARRE ANTER. 1/2 M	FRONT FASTENING BRACKET 1/2	1	_				
9	H602603000	ESCUADRA AMARRE ANTER. 1 M	FRONT FASTENING BRACKET 1	_	1				
	Q221342000	REMACHE EXAGONAL M5	HEXAGONAL RIVET M5	5	5				
10	H125403000	ANTERIOR MESA 1/2M G-700	FRONT BENCH 1/2M G-700	1	_				
10	H125409000	ANTERIOR MESA 1M G-700	FRONT BENCH 1M G-700	_	1				
	Q152004000	TORNIL. APLASTADO M5X13 A 304	FLAT HEADED SCREW M5x13 A 3	2	2				
11	H602803000	ZOCALO 7-05 Q	SKIRTING 7-05 Q	1	_				
11	H602816000	ZOCALO 7-10 Q	SKIRTING 7-10 Q	_	1				
	Q012031000	TORNILLO EXAGONAL M5X10 A.304	HEXAGONAL BOLT M5X10 A.304	2	2				
	Q302022000	ARANDELA 16X6X1.2 A.304	WASHER 16X6X1.2 A.304	2	2				

MOD.	COCINAS			ZONA	MUEBLE		
ITEM	CODIGO	DENOMINACION	TEXTO	CE7-20	CE7-40		
12	U952809000	PORTAMANDOS COMPLE. CE7-20	COMPL. CONTROL HOLDER CE7	1	-		
12	U952805000	PORTAMANDOS COMPLE. CE7-40	COMPL. CONTROL HOLDER CE7	-	1		
	Q152004000	TORNIL. APLASTADO M5X13 A 304	FLAT HEADED SCREW M5x13 A 304	4	4		
	Q302022000	ARANDELA 16X6X1.2 A.304	WASHER 16X6X1.2 A.304	2	2		
	U912805000	ESCUDO FAGOR G700	FAGOR EMBLEM G700	1	1		
	Q221023000	CLIP SUJECIÓN RÁPIDA Ø5	RAPID CONNECT CLIP Ø5	2	2		
13	U952806000	BASE CE7-20	BASE CE7-20	1	-		
13	U952803000	BASE CE7-40	BASE CE7-40	-	1		
	Q419005000	REMACHE 4X8 ALMG3 / ALUMINIO	RIVET 4X8 ALMG3 / ALUMINIUM	4	4		
14	H122801000	PANEL LATERAL SUP. IZDO. G700	LEFT UPPER SIDE PANEL G700	1	1		
	Q221342000	REMACHE EXAGONAL M5	HEXAGONAL RIVET M5	5	5		
	Q221343000	REMACHE EXAGONAL M6	HEXAGONAL RIVET M6	5	5		
15	Z200107000	PATA REGULABLE	ADJUSTABLE LEG	4	4		
	Q221345000	REMACHE EXAGONAL M10	HEXAGONAL RIVET M10	4	4		

Зип Общепит

vsezip.ru

+7(812)987-08-81

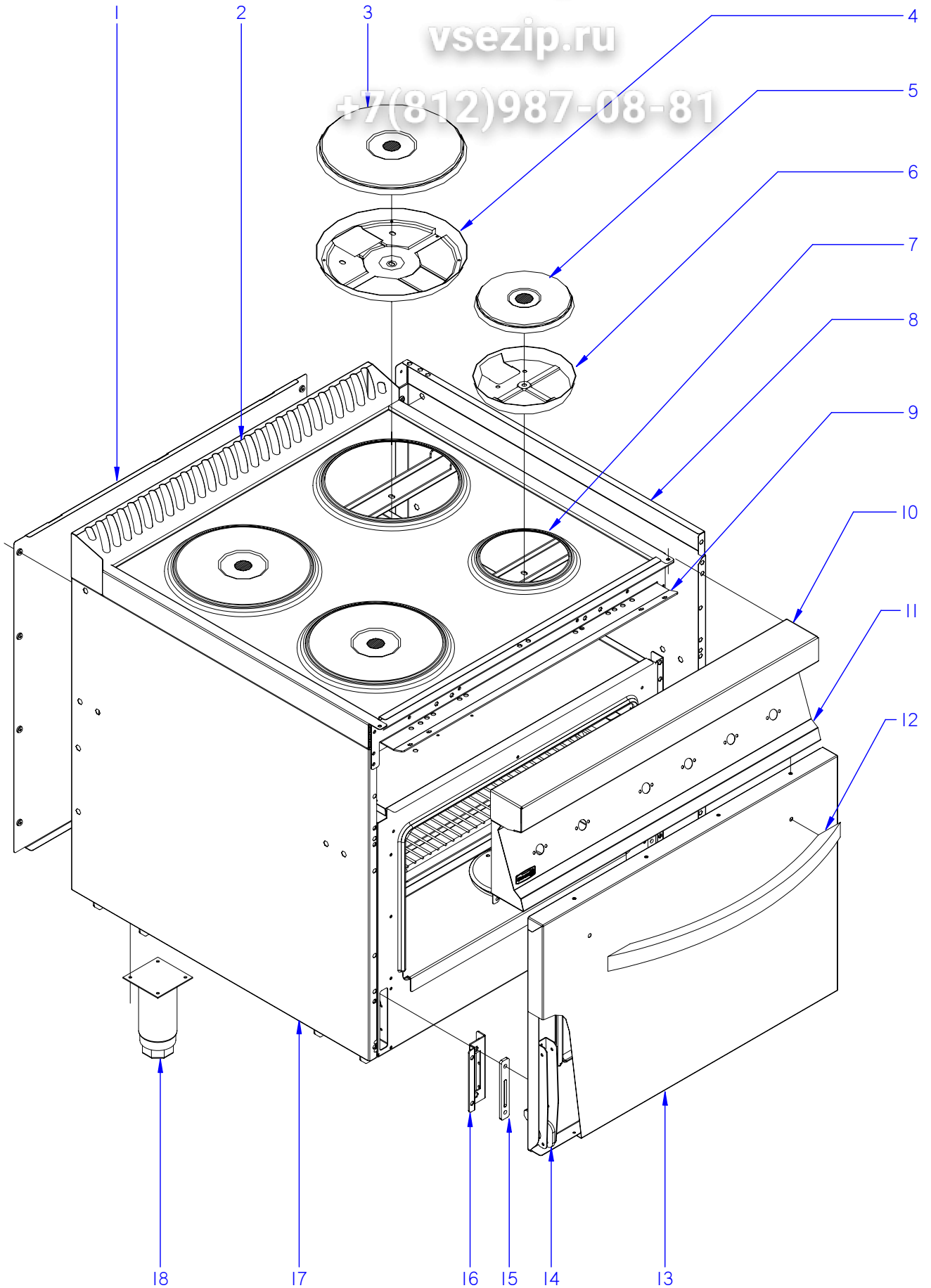

ITEM MARCADO EN COLOR = REPUESTO RECOMENDADO
COLOURED ITEM = RECOMMENDED SPARE PART

N plano	Firma	Fecha	Aparato	MUEBLE	Lamina	Fagor Industrial S.Coop. FAGOR
C-2041	<i>[Signature]</i>	2008-05	COCINA CE7-41		2	Oñate

MOD.		COCINAS		ZONA		MUEBLE	
ITEM	CODIGO	DENOMINACION	TEXTO	CE7-41			
1	S562805000	PANEL POSTERIOR G750	REAR PANEL G750	1			
	Q419005000	REMACHE 4X8 ALMG3 / ALUMINIO	RIVET 4X8 ALMG3 / ALUMINIUM	8			
2	S565401000	EMBELLECEDOR POSTERIOR 1M	REAR TRIM 1M	1			
3	U803000000	PLACA PUNTO ROJO 2600W-230V	RED POINT PLATE 2600W-230V	3			
4	U793030000	CAZOLETA	CASING	3			
5	U803002000	PLACA PUNTO ROJO 1500W-230V	RED POINT PLATE 1500W-230V	1			
6	U793031000	CAZOLETA 1500W.ULGOR C79A001	CASING 1500W.ULGOR C79A001	1			
	Z608410000	CASQUILLO AMARRE TECLADO	KEYBOARD ANCHORAGE BUSHI	4			
	Q162040000	TUERCA EXAGONAL M6	HEXAGONAL NUT M6	4			
	Q302022000	ARANDELA 16X6X1.2 A.304	WASHER 16X6X1.2 A.304	4			
7	U955401000	MESA 1M (CE7-41)	BENCH 1M (CE7-41)	1			
	Q012031000	TORNILLO EXAGONAL M5X10 A.304	HEXAGONAL BOLT M5X10 A.304	4			
8	U912802000	PANEL LATERAL DCHO. G700	RIGHT SIDE PANEL G700	1			
	Q221342000	REMACHE EXAGONAL M5	HEXAGONAL RIVET M5	13			
	Q221343000	REMACHE EXAGONAL M6	HEXAGONAL RIVET M6	2			
	Q012043000	TORNILLO EXAGONAL M6X20 A.304	HEXAGONAL BOLT M6X20 A.304	2			
	Q302022000	ARANDELA 16X6X1.2 A.304	WASHER 16X6X1.2 A.304	2			
	Q221343000	REMACHE EXAGONAL M6	HEXAGONAL RIVET M6	7			
9	H602603000	ESCUADRA AMARRE ANTER. 1 M	FRONT FASTENING BRACKET 1	1			
	Q221342000	REMACHE EXAGONAL M5	HEXAGONAL RIVET M5	16			
	Q012031000	TORNILLO EXAGONAL M5X10 A.304	HEXAGONAL BOLT M5X10 A.304	6			
10	H125409000	ANTERIOR MESA 1M G-700	FRONT BENCH 1M G-700	1			
	Q152004000	TORNIL. APLASTADO M5X13 A 304	FLAT HEADED SCREW M5x13 A 3	2			
11	U952802000	PORTAMANDOS COMPLE. CE-741	COMPL. CONTROL HOLDER CE-7	1			
	Q152004000	TORNIL. APLASTADO M5X13 A 304	FLAT HEADED SCREW M5x13 A 3	4			
	Q302022000	ARANDELA 16X6X1.2 A.304	WASHER 16X6X1.2 A.304	2			
	U912805000	ESCUDO FAGOR G700	FAGOR EMBLEM G700	1			
	Q221023000	CLIP SUJECIÓN RÁPIDA Ø5	RAPID CONNECT CLIP Ø5	2			

MOD.	COCINAS		vsezip.ru	MUEBLE				
ITEM	CODIGO	DENOMINACION	TEXTO	CE7-41				
12	U020504000	ASA DE HORNO COMPL. G 900	COMPL. OVEN HANDLE G 900	1				
	Q302022000	ARANDELA 16X6X1.2 A.304	WASHER 16X6X1.2 A.304	2				
	Q012041000	TORNILLO EXAGONAL M6X10 A.304	HEXAGONAL BOLT M6X10 A.304	2				
	Q162040000	TUERCA EXAGONAL M6	HEXAGONAL NUT M6	2				
	12038310	KIT PUERTA HORNO	OVEN DOOR KIT	1				
13	U910501000	PUERTA DE HORNO G700	OVEN DOOR G700	1				
	U910502000	CONTRAPUERTA HORNO G700	OVEN DOOR REVERSE G700	1				
14	U020528000	BISAGRA CIERRE HORNO	OVEN LOCK HINGE	2				
	Q152022000	TORNILLO M.6X8	BOLT M.6X8	6				
15	U915619000	EMBELLECEDOR GUIA BISAGRA	HINGE GUIDE TRIM	2				
	Q152045000	TORNILLO AMARRRE M6X25	FASTENING BOLT M6X25	4				
16	U915604000	AMARRE GUIA BISAGRA HORNO	OVEN HINGE GUIDE FASTENING	2				
	Q412000000	REMACHE TUBULAR 4 x 8	TUBULAR RIVET 4 x 8	6				
	Q222042000	REMACHE EXAGONAL ROSCA M6	HEXAGONAL RIVET THREAD M6	4				
17	U912801000	PANEL LATERAL IZDO. G700	LEFT SIDE PANEL G700	1				
	Q221342000	REMACHE EXAGONAL M5	HEXAGONAL RIVET M5	13				
	Q221343000	REMACHE EXAGONAL M6	HEXAGONAL RIVET M6	2				
	Q012043000	TORNILL. EXAGONAL M6X20 A.304	HEXAGONAL BOLT M6X10 A.304	2				
	Q302022000	ARANDELA 16X6X1.2 A.304	WASHER 16X6X1.2 A.304	2				
	Q221343000	REMACHE EXAGONAL M6	HEXAGONAL RIVET M6	7				
18	X260151000	PATA REGULABLE	ADJUSTABLE LEG	4				
	Q411304000	REMACHE AVIBULB Ø 4,8	AVIBULB RIVET Ø 4.8	16				

Зип Общепит

ysezip.ru

+7(812)987-08-81

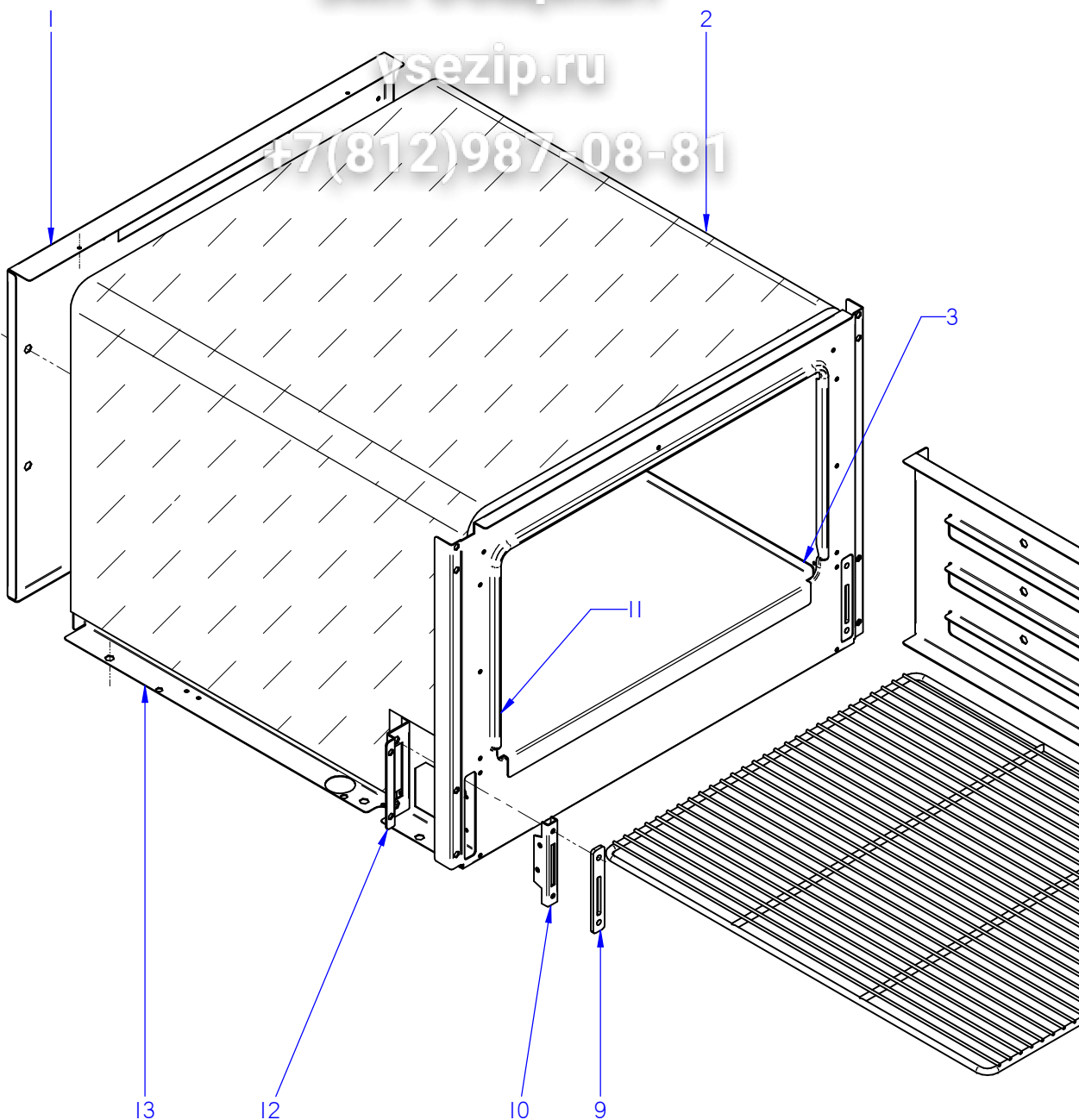

ITEM MARCADO EN COLORES = REPUUESTO RECOMENDADO
COLOURED ITEM = RECOMMENDED SPARE PART

N.º plano	Firma	Fecha	Aparato	Lamina	Fagor Industrial S. Coop. FAGOR Ortze
C-2042	<i>(Signature)</i>	2008-05	COCINA CE7-41	3	

+7(812)987-08-81

MOD.		COCINAS	ZONA	HORNO			
ITEM	CODIGO	DENOMINACION	TEXTO	CE7-41			
1	U955602000	POSTERIOR HORNO ELECTRICO	ELECTRIC OVEN REAR	1			
2	U325621000	AISLANTE 1455x670x20-AL1C	INSULATION 1455x670x20-AL1C	1			
3	U955613000	SOLERA HORNO ELECTRICO G700	ELECTRIC OVEN FLOOR G700	1			
4	U915607000	GUIA LATERAL HORNO G700	OVEN SIDE GUIDE G700	2			
5	U915616000	SUPLEM. AMARRE GUIA LATERAL	SUPP. FASTENING SIDE GUIDE	2			
6	Q221343000	REMACHE EXAGONAL M6	HEXAGONAL RIVET M6	4			
7	Q151336000	TORNILLO SOPORTE GUIAS	GUIDE SUPPORT BOLT	4			
8	U135642000	PARRILLA DE HORNO	OVEN TRAY	1			
9	U915619000	EMBELLECEDOR GUIA BISAGRA	HINGE GUIDE TRIM	2			
	Q152045000	TORNILLO AMARRRE M6X25	FASTENING BOLT M6X25	4			
10	U010512000	GUIA BISAGRA HORNO	OVEN HINGE GUIDE	2			
10	12041846	GUIA BISAGRA G700 Y G900	G700 / G900 HINGE GUIDE	2			
11	U025623000	JUNTA PUERTA HORNO INOX.	OVEN DOOR SEAL INOX.	1			
11	U965613000	JUNTA HORNO FIBRA DE VIDRIO	FURNACE FIBERGLASS BOARD	1			
12	U915604000	AMARRE GUIA BISAGRA HORNO	OVEN HINGE GUIDE FASTENING	2			
	Q412000000	REMACHE TUBULAR 4 x 8	TUBULAR RIVET 4 x 8	6			
	Q222042000	REMACHE EXAGONAL ROSCA M6	HEXAGONAL RIVET THREAD M6	4			
13	U955601000	CUERPO HORNO ELECTR. G700	ELECTR. OVEN BODY G700	1			
13	U965616000	CUERPO HORNO ELECTR. AD	ELECTR. OVEN BODY AD	1			

Зип Общепит

vsezip.ru

+7(812)987-08-81

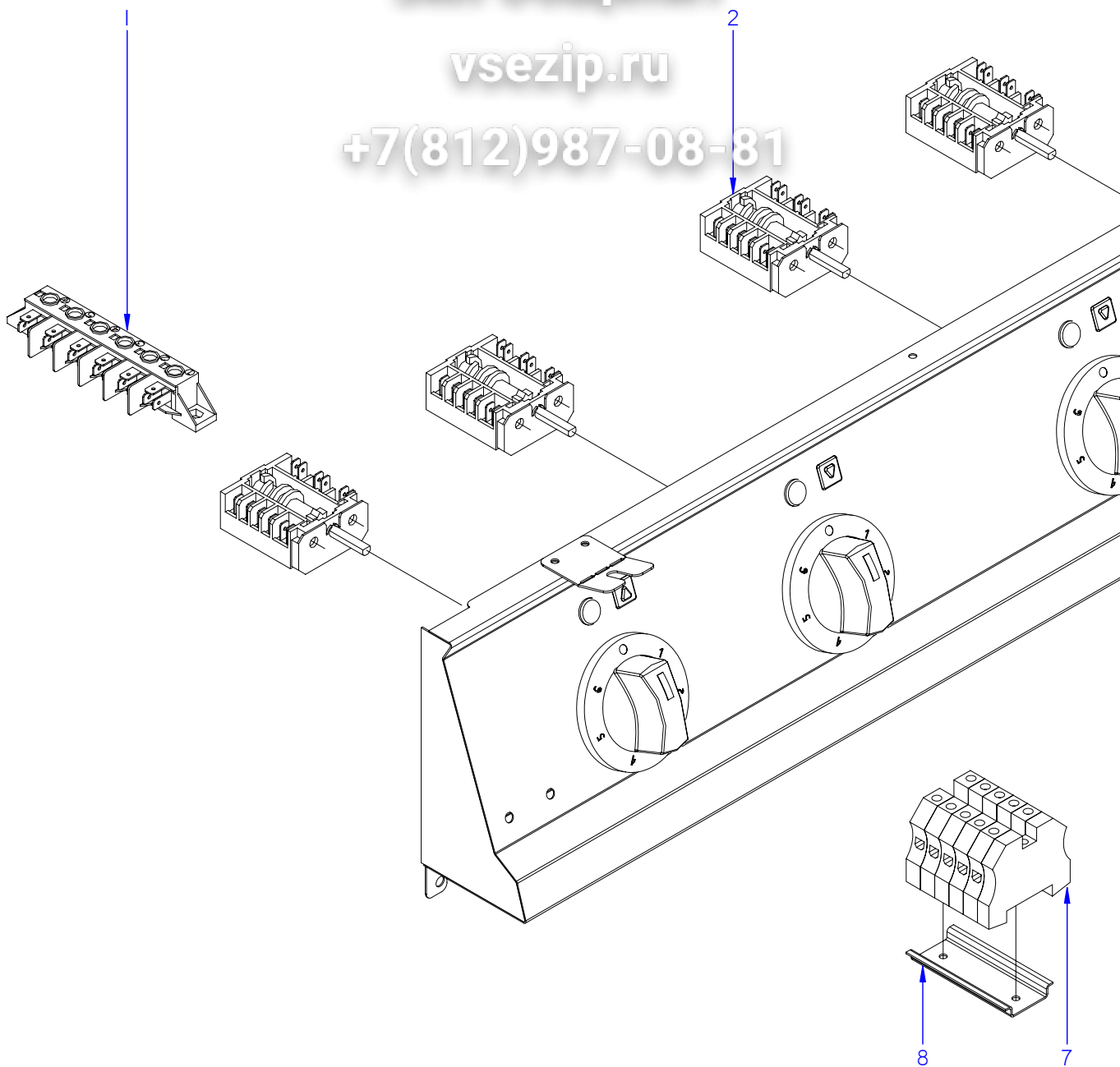

ITEM MARCADO EN COLOR = REPUESTO RECOMENDADO
COLOURED ITEM = RECOMMENDED SPARE PART

N plano	Firma	Fecha	Aparato	Lamina	Fagor Industrial S. Coop.
C-2043	<i>(Signature)</i>	2008-05	COCINA CET-20 / CET-40	4	Ortfe
PARTE FUNCIONAL ELECTRICA					



Зип Общепит

MOD.	COCINAS	vsezip.ru	PARTE FUNCIONAL ELECTRICA
------	---------	-----------	---------------------------

ITEM	CODIGO	DENOMINACION	TEXTO	CE7-20	CE7-40				
1	R253044000	REGLETA AUXILIAR FV-122	AUXILIARY TERMINAL STRIP FV-	1	1				
	Q152004000	TORNIL. APLASTADO M5X13 A 304	FLAT HEADED SCREW M5x13 A 304	2	2				
2	U673007000	CONMUTADOR EGO	EGO SWITCH	2	4				
	Q151320000	TOR. ALOMADO M4X6 H.ZINCADO	CURVED SCREW M4X6 H. ZINC	4	8				
3	U952809000	PORTAMANDOS COMPLE. CE7-20	COMPL. CONTROL HOLDER CE7-	1	-				
3	U952805000	PORTAMANDOS COMPLE. CE7-40	COMPL. CONTROL HOLDER CE7-	-	1				
	Q152004000	TORNIL. APLASTADO M5X13 A 304	FLAT HEADED SCREW M5x13 A 304	4	4				
4	R693056000	PILOTO AMBAR 41227000A4	AMBER PILOT 41227000A4	2	4				
4	12024669	PILOTO AMBAR Ø18	AMBER PILOT Ø18	2	4				
5	U952101000	MANDO Ø6 (CONMUTADOR-MESA)	CONTROL Ø6 (SWITCH-BENCH)	2	4				
6	R023013000	PRENSA ESTOPAS PG-21	STUFFING BOX PG-21	1	1				
7	P453025000	BORNES 10 WDU-10203.O	TERMINALS 10 WDU-10203.O	3	3				
	P453026000	BORNE TIER 10 WPE-10103.O	TERMINAL TIER 10 WPE-10103.O	1	1				
	Z263302000	BORNA AZUL PASO	BLUE THROUGH TERMINAL	1	1				
	Z263303000	TOPE FINAL	END STOP	1	1				
	Z683068000	SEÑALIZ.DEK-6WEIDMULLER	SIGNS DEK-6WEIDMULLER	1	1				
8	Z103083000	GUIA CONTACTOR L-73 "	CONTACTOR GUIDE L-73 "	1	1				
	Q419005000	REMACHE 4X8 ALMG3 / ALUMINIO	RIVET 4X8 ALMG3 / ALUMINIUM	2	2				

Зип Общежит

vsezip.ru

+7(812)947-08-81

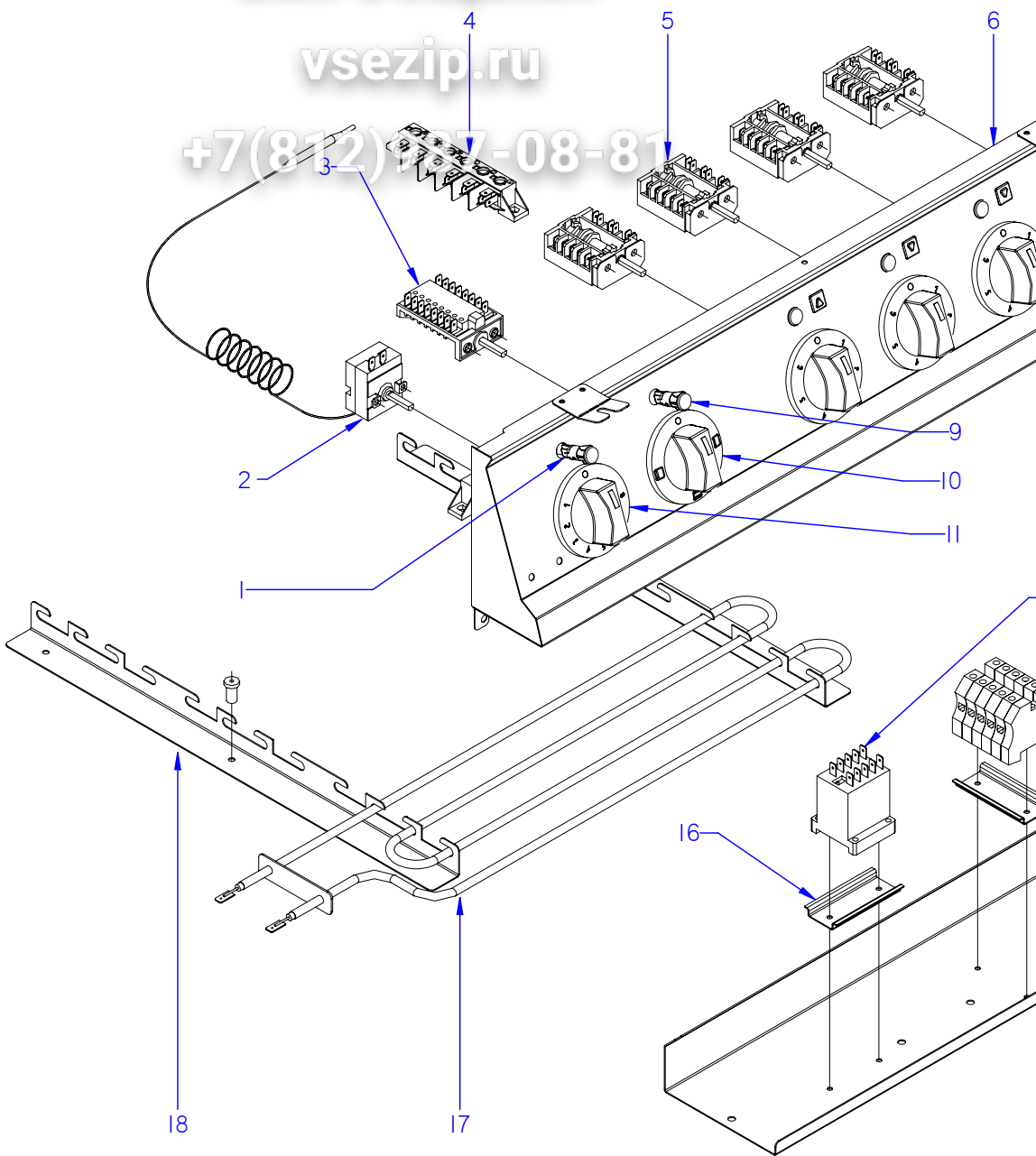

ITEM MARCADO EN COLOR = REPUESTO RECOMENDADO
COLOURED ITEM = RECOMMENDED SPARE PART

N plano	Firma	Fecha	Aparato	Lamina	Fagor Industrial S. Coop.
C-2044	<i>[Signature]</i>	2008-05	COCINA CE7-41	5	Ortfe
PARTE FUNCIONAL ELECTRICA					



Зип Общепит

MOD.	COCINAS	vsezip.ru	PARTE FUNCIONAL ELECTRICA
-------------	----------------	-----------	----------------------------------

ITEM	CODIGO	DENOMINACION	TEXTO	CE7-41				
1	R693056000	PILOTO AMBAR 41227000A4	AMBER PILOT 41227000A4	1				
1	12024669	PILOTO AMBAR Ø18	AMBER PILOT Ø18	1				
2	X153000000	TERMOSTATO 50-310 C	THERMOSTAT 50-310 C	1				
	Q151320000	TOR. ALOMADO M4X6 H.ZINCADO	CURVED SCREW M4X6 H. ZINC	4				
3	U673006000	CONMUTADOR	SWITCH	1				
4	R253044000	REGLETA AUXILIAR FV-122	AUXILIARY TERMINAL STRIP FV-1	1				
	Q152004000	TORNIL. APLASTADO M5X13 A 304	FLAT HEADED SCREW M5x13 A 3	2				
5	U673007000	CONMUTADOR EGO	EGO SWITCH	4				
	Q151320000	TOR. ALOMADO M4X6 H.ZINCADO	CURVED SCREW M4X6 H. ZINC	8				
6	U952802000	PORTAMANDOS COMPLE. CE-741	COMPL. CONTROL HOLDER CE-7	1				
7	R693056000	PILOTO AMBAR 41227000A4	AMBER PILOT 41227000A4	4				
7	12024669	PILOTO AMBAR Ø18	AMBER PILOT Ø18	4				
8	U952101000	MANDO Ø6 (CONMUTADOR-MESA)	CONTROL Ø6 (SWITCH-BENCH)	4				
9	R693055000	PILOTO VERDE 41227000C7	GREEN PILOT 41227000C7	1				
9	12047390	PILOTO VERDE 230V AC 8KW 16MM	GREEN PILOT 230V AC 8KW 16M	1				
10	U952102000	MANDO Ø6 (CONMUTAD.-HORNO)	CONTROL Ø6 (SWITCH-OVEN)	1				
11	X482101000	MANDO Ø6 (TERMOSTAO-HORNO)	CONTROL Ø6 (THERMOSTAT -OV	1				
12	Z213007000	CONTACTOR 230 V. 50-60 HZ	CONTACTOR 230 V. 50-60 HZ	1				
13	P453025000	BORNES 10 WDU-10203.O	TERMINALS 10 WDU-10203.O	3				
	Z683097000	BORNA NEUTRO AZUL 76A 1 VIA UL	BLUE NEUTRAL TERMINAL 76A	1				
	P453026000	BORNE TIER 10 WPE-10103.O	TERMINAL TIER 10 WPE-10103.O	1				
	U803009000	BORNA AZUL PASO 16MM	BLUE TAP TERMINAL 16MM	1				
	Z263303000	TOPE FINAL	END STOP	1				
	Z683068000	SEÑALIZ.DEK-6WEIDMULLER	SIGNS DEK-6WEIDMULLER	1				
14	R023013000	PRENSA ESTOPAS PG-21	STUFFING BOX PG-21	1				
15	U953001000	CHAPA AMAR CONTACT. HORNO	CONTACT. FASTE. PLATE OVEN	1				
	Q152004000	TORNIL. APLASTADO M5X13 A 304	FLAT HEADED SCREW M5x13 A 3	3				
16	Z103083000	GUIA CONTACTOR L-73 "	CONTACTOR GUIDE L-73 "	2				
	Q419005000	REMACHE 4X8 ALMG3 / ALUMINIO	RIVET 4X8 ALMG3 / ALUMINIUM	4				
17	U803004000	RESISTENCIA 1000W-230V	RESISTOR 1000W -230V	6				
18	U805613000	ESCUADRA SOPOR. RESISTENCIAS	SUPP. BRACKET RESISTORS	4				

MOD.

ZONA

CAMBIOS PARA PASAR DE (380-415V. 50H
(440V 3)

vsezip.ru

+7(812)987-08-81

ITEM	CODIGO	DENOMINACION		CE7-20	CE7-40	CE7-41		
		PIEZAS A ELIMINAR	PARTS TO BE REMOVED					
3	U803000000	PLACA PUNTO ROJO 2600W-230V	RED POINT PLATE 2600W-230V	2	3	3		
5	U803002000	PLACA PUNTO ROJO 1500W-230V	RED POINT PLATE 1500W-230V	-	1	1		
		PIEZAS A INTRODUCIR	PARTS TO BE INCLUDED					
3	U803070000	PLACA PUNTO ROJO 2600W-400V	RED POINT PLATE 2600W-400V	2	3	3		
5	U803071000	PLACA PUNTO ROJO 1500W-400V	RED POINT PLATE 1500W-400V	-	1	1		
17	U803072000	RESISTENCIA 150K 1/4W	RESISTOR 150K 1/4W	-	-	6		
17	U803073000	RESISTENCIA 8K2 6W	RESISTOR 8K2 6W	-	-	1		

MOD.		COCINAS		ZONA		REPUESTOS RECOMENDADOS RECOMMENDED SPARE PART		
ITEM	CODIGO	DENOMINACION	TEXTO	CE7-20	CE7-40	CE7-41		
3	U803000000	PLACA PUNTO ROJO 2600W-230V	RED POINT PLATE 2600W-230V	2	3	_		
5	U803002000	PLACA PUNTO ROJO 1500W-230V	RED POINT PLATE 1500W-230V	_	1	_		
3	U803000000	PLACA PUNTO ROJO 2600W-230V	RED POINT PLATE 2600W-230V	_	_	3		
5	U803002000	PLACA PUNTO ROJO 1500W-230V	RED POINT PLATE 1500W-230V	_	_	1		
14	U020528000	BISAGRA CIERRE HORNO	OVEN LOCK HINGE	_	_	2		
16	U915604000	AMARRE GUIA BISAGRA HORNO	OVEN HINGE GUIDE FASTENING	_	_	2		
10	12041846	GUIA BISAGRA G700 Y G900	G700 / G900 HINGE GUIDE	_	_	2		
12	U965613000	JUNTA HORNO FIBRA DE VIDRIO	FURNACE FIBERGLASS BOARD	_	_	1		
2	U673007000	CONMUTADOR EGO	EGO SWITCH	2	4	_		
4	12024669	PILOTO AMBAR Ø18	AMBER PILOT Ø18	2	4	_		
1	12024669	PILOTO AMBAR Ø18	AMBER PILOT Ø18	_	_	1		
2	X153000000	TERMOSTATO 50-310 C	THERMOSTAT 50-310 C	_	_	1		
3	U673006000	CONMUTADOR	SWITCH	_	_	1		
5	U673007000	CONMUTADOR EGO	EGO SWITCH	_	_	4		
7	12024669	PILOTO AMBAR Ø18	AMBER PILOT Ø18	_	_	4		
9	12047390	PILOTO VERDE 230V AC 8KW 16MM	GREEN PILOT 230V AC 8KW 16M	_	_	1		
17	U803004000	RESISTENCIA 1000W-230V	RESISTOR 1000W -230V	_	_	6		

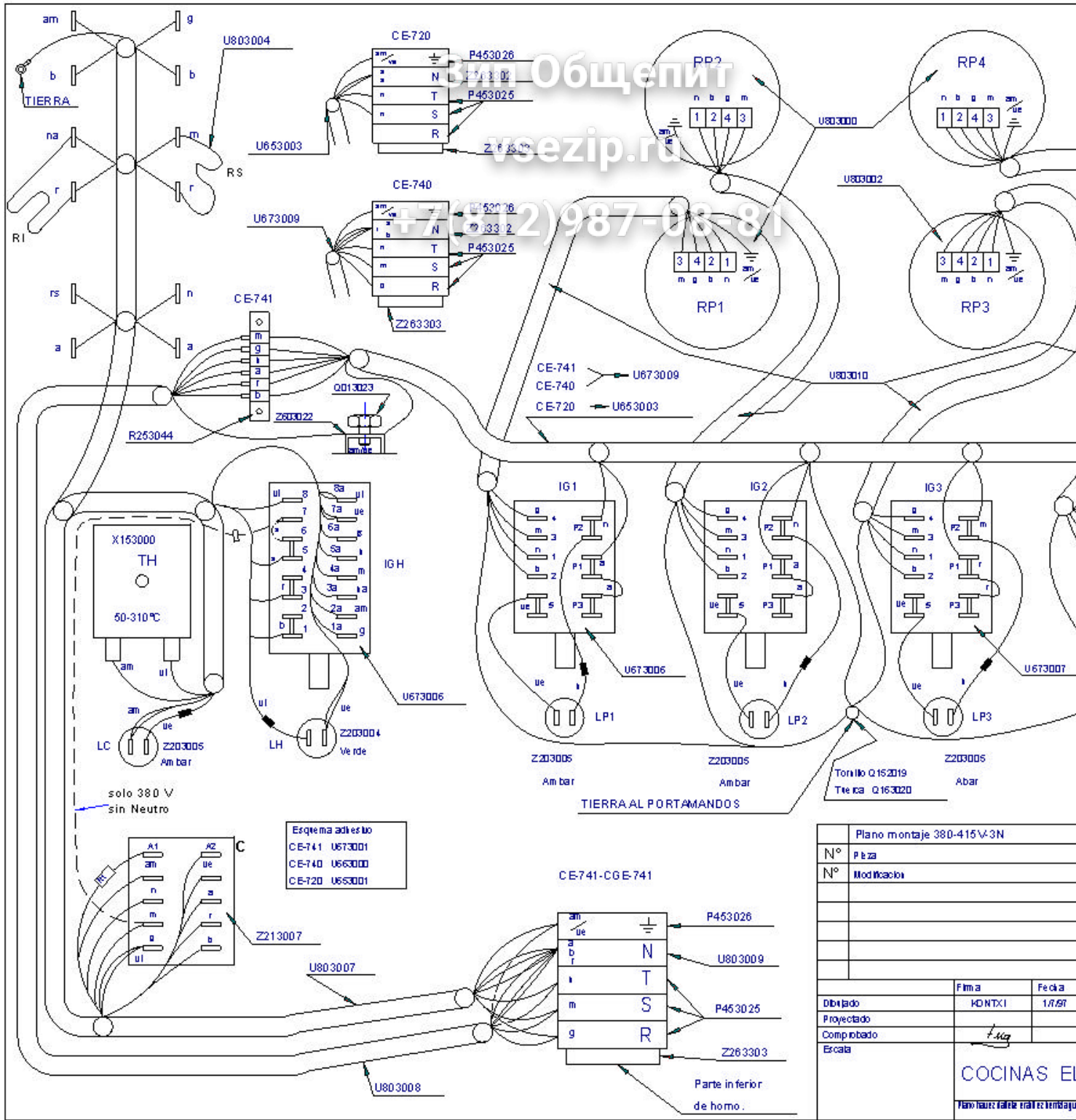

311-06щепит
 vsezip.ru
 +7 (495) 2)987-08-81

Plano montaje 380-415V-3N		
Nº	Pieza	
Nº	Modificación	
Dibujado		Firma
Proyectado		MDNTX1
Comprobado		1/1/87
Escala		1:100
COCINAS EL <small>Planos, instalación, mantenimiento y reparación de cocinas</small>		

Зип Общежит

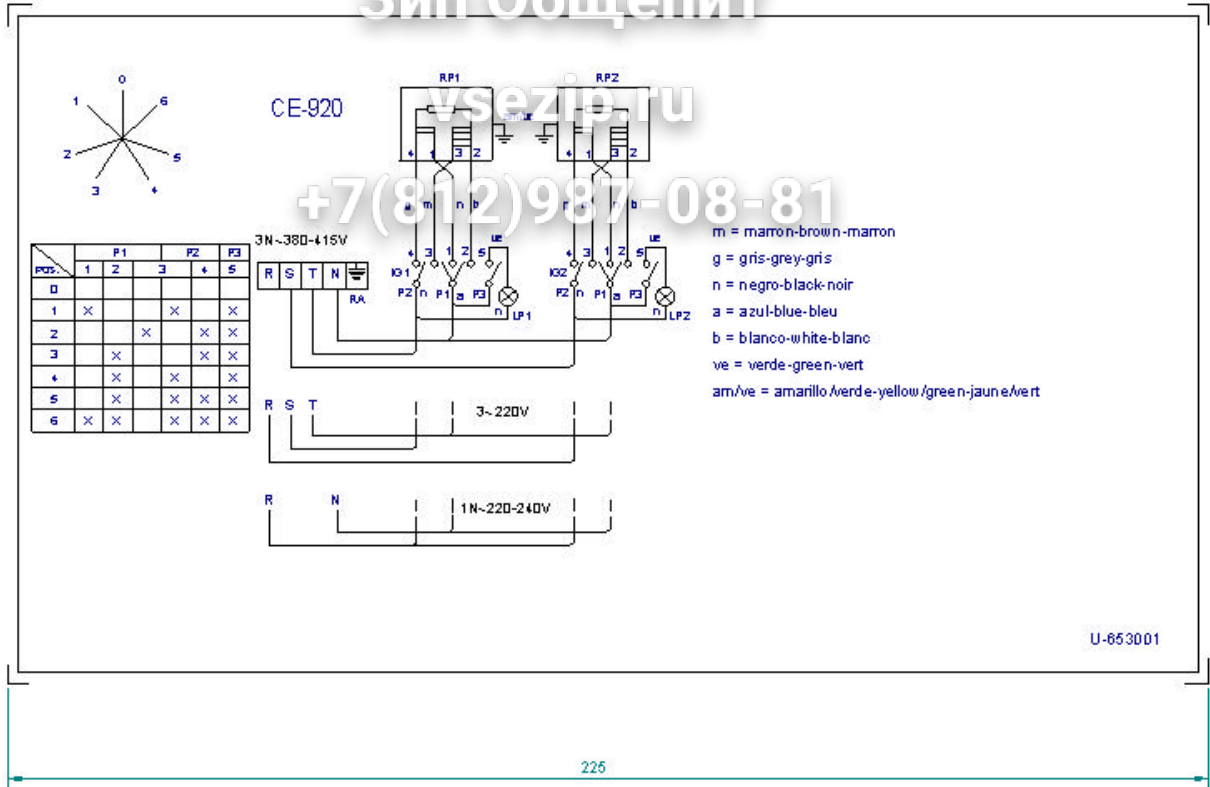

NOTA

- Las inscripciones resistirán sin modificación apreciable el frotamiento durante 15 seg. de un algodón impregnado en gasolina.

RA: Regleta de Alimentación
IG 1, IG 2: Conmutadores de placas eléctricas
RP 1, RP 2: Placas eléctricas
LP 1, LP 2: Lámpara Calentamiento de Placas

	Esquema teorico	
Nº	Plaza	
Nº	Modificacio	
	Firma	Fecha
Dibujado	Plaza B	21-4-97
Proyectado		
Comprobado		
Escala		
	1/1	C
	Hidroizolación, pintado y embague.	

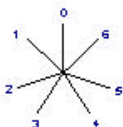

POS.	1	2	3	4	5
0					
1	x		x		x
2		x		x	
3			x		x
4	x		x		x
5	x	x		x	
6	x	x	x	x	x

- r = rojo-red-rouge
- m = marron-brown-marron
- g = gris-grey-gris
- n = negro-black-noir
- a = azul-blue-bleu
- b = blanco-white-blanco
- ue = verde-green-vert
- am/ue = amarillo/verde-yellow/green-jaune/vert

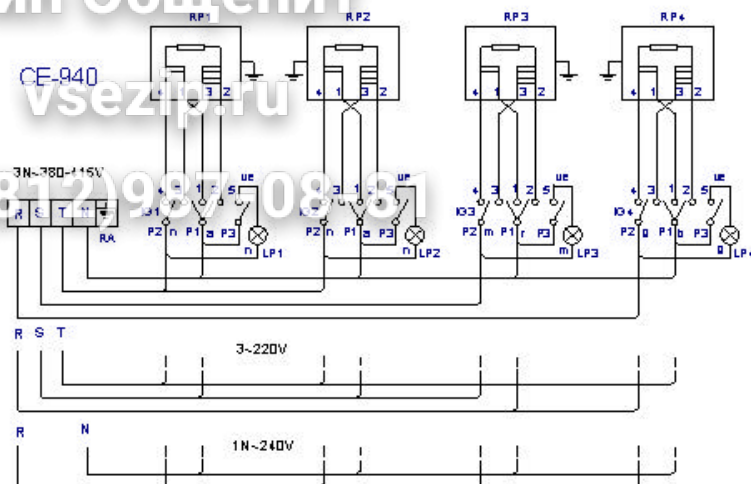

U-663000

NOTA

- Las inscripciones resistirán sin modificación apreciable el frotamiento durante 15 seg. de un algodón impregnado en gasolina.

- RA: Regleta de Alimentación
- IG1, IG2, IG3, IG4: Conmutadores de placas eléctricas
- RP1, RP2, RP3, RP4: Placas eléctricas
- LP1, LP2, LP3, LP4: Lámpara Calentamiento de Placas

Esquema teorico		
Nº	Plaza	
Nº	Modificación	
Firma		Fecha
Dibujado	Plaza	22-4-97
Proyectado		
Comprobado		
Executado		
1/1		
Firmas de los autores y revisores de este proyecto		

CE 941 CE 741

CE 641

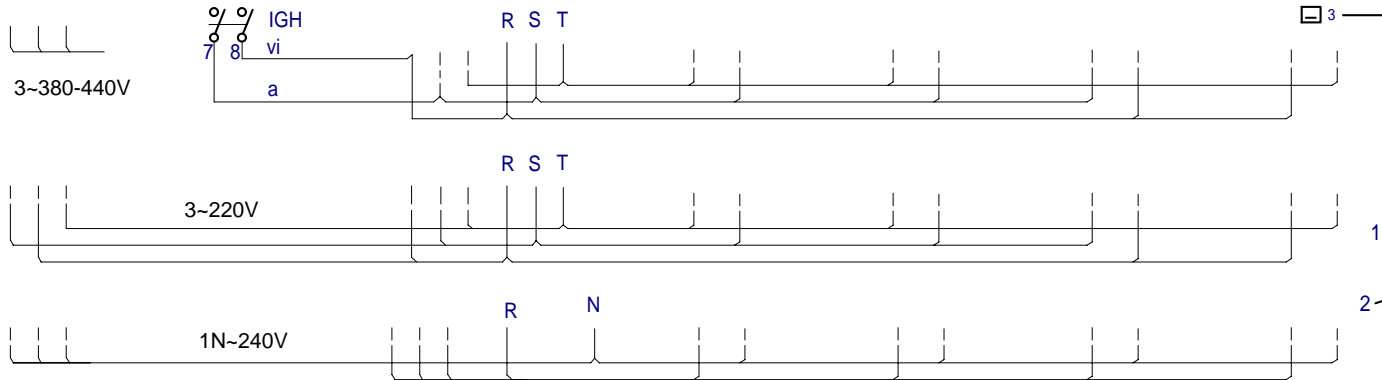
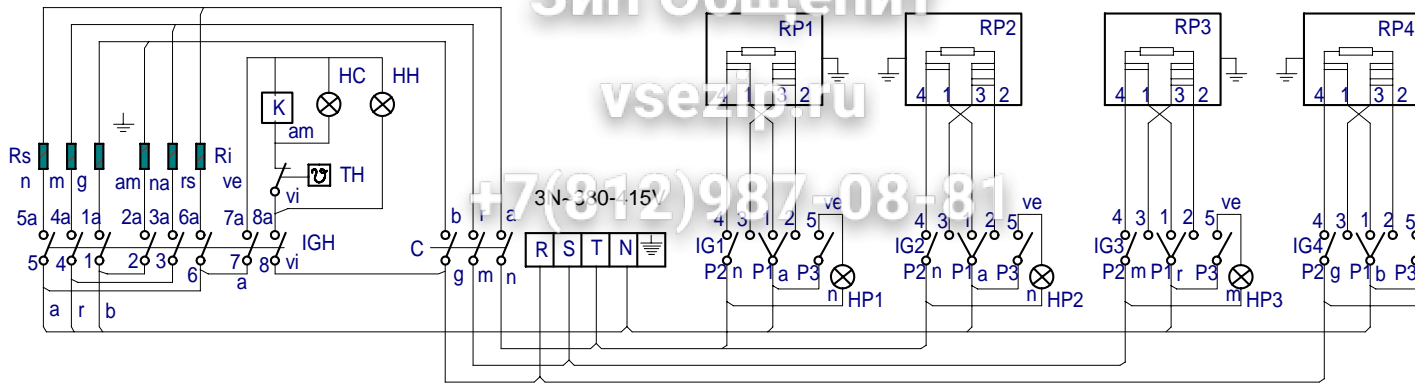

- HPx :Lampara Calentamiento Placas / Heating lamp (electrical plates)
- IGx :Conmutadores de placas electricas / Main switch (electrical plates)
- IGH :Conmutador General Horno / Oven main switch
- HH : Lampara Horno Encendido / Main lamp (oven)
- HC : Lampara Calentamiento Horno / Heating lamp (oven)
- Ri : Resistencia Horno Inferior / Lower resistance (oven)
- Rs : Resistencia Horno Superior / Top resistance (oven)
- RPx :Placas electricas / Electrical plates
- BH : Termostato de Horno / Thermostat (oven)
- TFR:Transformador / Transformer
- K: Contactor / Contactor

Esquema teorico adhesivo		
Nº	Pieza	
Nº	Modificacion	
Firma		Fecha
Dibujado	implazaola	31/05/05
Proyectado		
Comprobado	<i>lefo g</i>	
Escala		
1/1	C	
Plano hau ez daiteke erabili ez berria gure		