

Зип Общепит

vsezip.ru

DESPIECE TECNICO

+7(812)987-08-81

**Freidoras
Fryers
Friteuses
Friteusen
Friggitrici
Fritadeiras**

GAMA SNACK

Modelos:

FG6-05

FG6-10

Junio 2008 June

Revisado Mayo 2013 May Revised

FAGOR 

F A G O R I N D U S T R I A L

Зип Общепит

vsezip.ru

+7(812)987-08-81

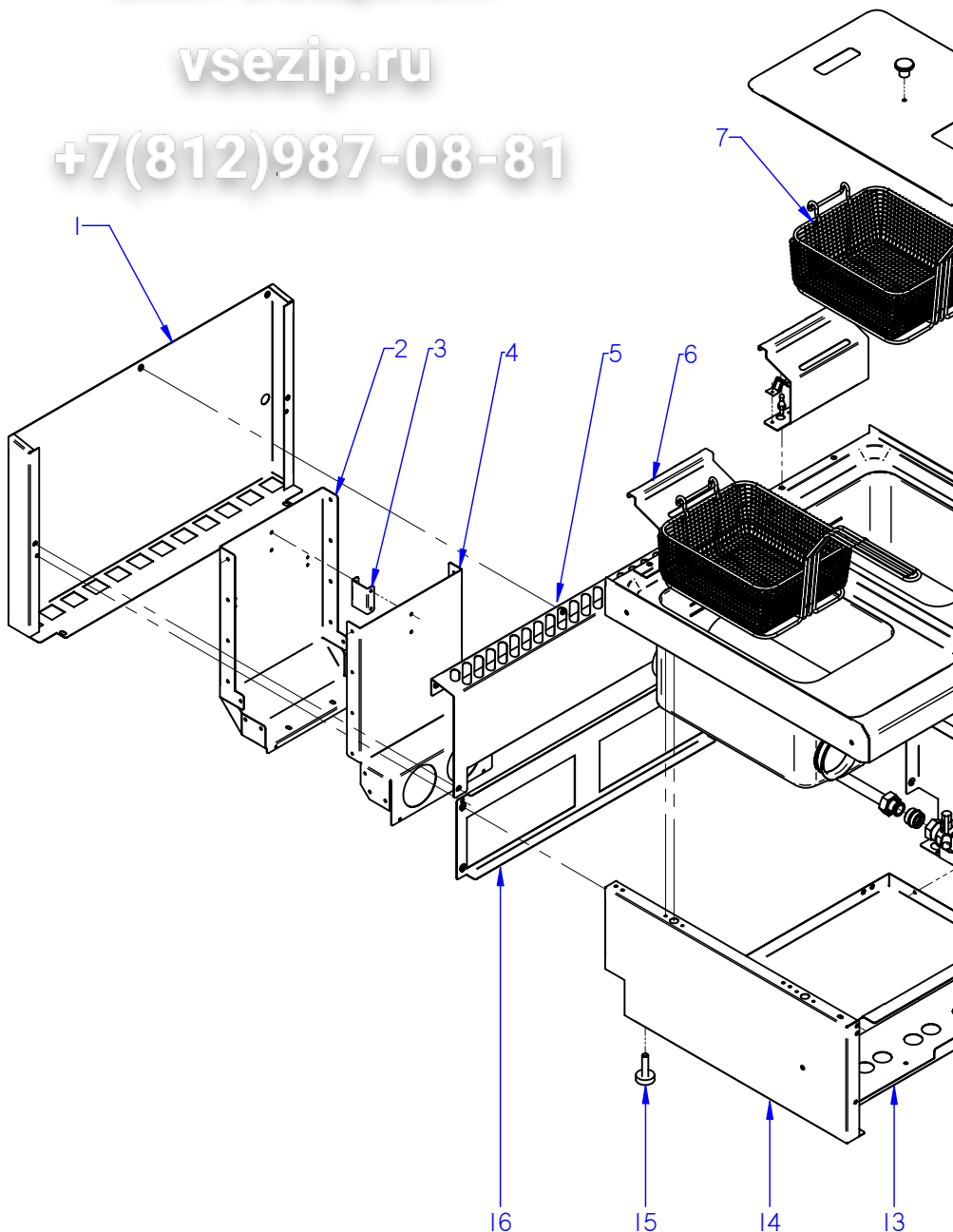

ITEM MARCADO EN COLOR = REPUESTO RECOMENDADO
COLOURED ITEM = RECOMMENDED SPARE PART

N plano C-2390	Firma <i>[Signature]</i>	Fecha 2009-06	Aparato FREIDORA FG6-05 / FG6-10	Lamina 1	Fagor Industrial S. Coop. FAGOR Orte
MUEBLE					

MOD.		FREIDORAS / FRYERS		ZONA		MUEBLE / UNIT			
ITEM	CODIGO	DENOMINACION	TEXTO	FG6-05	FG6-10				
1	J142809000	PROTECC. CHIMENEA POST. 400	PROTECTION CHIMEMEY POS.	1	-				
1	J142815000	PROTECC. CHIMENEA POST. 400	PROTECTION CHIMEMEY POS.	1	-				
S/Nº	J142627000	BASE PROTECTOR CHIMEN. 400	PROTEC. CHIMEMEY BASE 400	1	-				
S/Nº	J142627000	BASE PROTECTOR CHIMEN. 400	PROTEC. CHIMEMEY BASE 400	1	-				
1	J142812000	PROTECC. CHIMENEA POST. 600	PROTECTION CHIMEMEY POS.	-	1				
1	J142816000	PROTECC. CHIMENEA POST. 600	PROTECTION CHIMEMEY POS.	-	1				
S/Nº	J142628000	BASE PROTECTOR CHIMEN. 600	PROTEC. CHIMEMEY BASE 600	-	1				
S/Nº	J142628000	BASE PROTECTOR CHIMEN. 600	PROTEC. CHIMEMEY BASE 600	-	1				
2	J142607000	POSTERIOR CHIMENEA FG6-05	REAR CHIMENEY FG6-05	1	2				
2	J142625000	POSTERIOR CHIMENEA FG6-05	REAR CHIMENEY FG6-05	1	2				
3	J142609000	DISTANCIADOR CHIMENEA	DISTANCE FROM CHIMNEY	1	2				
4	J142608000	FRONTAL CHIMENEA FG6-05	CHIMENEY FRONT FG6-05	1	2				
4	J142626000	FRONTAL CHIMENEA FG6-05	CHIMENEY FRONT FG6-05	1	2				
	Q419005000	REMACHE 4X8 ALMG3 / ALUMINIO	RIVET 4X8 ALMG3 / ALUMINIUM	22	32				
5	J142810000	PROTECCION CHIMENEA ANT. 400	PROTECTION CHIMENEY ANT	1	-				
5	J142829000	PROTECCION CHIMENEA FREID.	PROTECTION CHIMENEY	1	-				
5	J142813000	PROTECCION CHIMENEA ANT. 600	PROTECTION CHIMENEY ANT	-	1				
5	J142830000	PROTECCION CHIMENEA ANT. 600	PROTECTION CHIMENEY ANT	-	1				
	Q012031000	TORNILLO EXAGONAL M5x10 A304	HEXAGONAL BOLT M5x10 A304	4	4				
	Q302022000	ARANDELA 16x6x1,2 A304	WASHER 16x6x1.2 A304	4	4				
6	J152806000	SOP. CESTILLO FREIDORA SNACK	SOP. BASKETS FRYERS SNACK	1	2				
6	J142837000	SOP. CESTILLO FREIDORA SNACK	SOP. BASKETS FRYERS SNACK	1	2				
	Q419007000	REMACHE TUBULAR C/V Ø3.2X6	TUBULAR RIVET C/V Ø3.2X6	4	8				
	X010503000	CIERRE MUELLE	LOCK SPRING	2	4				
	Z442918000	CLIP CIERRE	LOCK SPRING	2	4				
	X012612000	PITON CIERRE	LOCK SPIKE	2	4				
	Z442919000	PITON CIERRE	LOCK SPIKE	2	4				
7	J156501000	CESTILLO FREIDORA SNACK	CESTILLO FRIERS SNACK	1	2				
7a	J155408000	TAPA FREIDORA SNACK FG6-05	COVER SNACK FG6-05 FRYER	1	-				
7a	J155424000	TAPA FREIDORA SNACK FG6-10	COVER SNACK FG6-10 FRYER	-	2				
S/Nº	X166154000	POMO PARA TAPA	KNOB FOR COVER	1	2				

MOD.		FREIDORAS / FRYERS		ZONA		MUEBLE / UNIT			
ITEM	CODIGO	DENOMINACION	TEXTO	FG6-05	FG6-10				
8	J145410000	CUBA COMPLETA FG6-05	CUBE FG6-05 COMPL.	1	-				
8	J145446000	CUBA COMPLETA FG6-05	CUBE FG6-05 COMPL.	1	-				
8	J145452000	CUBA COMPLETA FG6-05	CUBE FG6-05 COMPL.	1	-				
8	J145415000	CUBA COMPLETA FG6-10	CUBE FG6-10 COMPL.	-	1				
8	J145448000	CUBA COMPLETA FG6-10	CUBE FG6-10 COMPL.	-	1				
8	J145454000	CUBA COMPLETA FG6-10	CUBE FG6-10 COMPL.	-	1				
	Q221342000	REMACHE EXAGONAL M5	HEXAGONAL RIVET M5	10	10				
	X012612000	PITON CIERRE	LOCK SPIKE	4	4				
	Z442919000	PITON CIERRE	LOCK SPIKE	4	4				
9	J002802000	PANEL LATERAL DERECHO	RIGHT SIDE PANEL	1	1				
9	J002834000	PANEL LATERAL DERECHO	RIGHT SIDE PANEL	1	1				
	Q221342000	REMACHE EXAGONAL M5	HEXAGONAL RIVET M5	1	1				
	Q419007000	REMACHE TUBULAR C/V D3.2X6	TUBULAR RIVET C/V D3.2X6	8	8				
	X010503000	CIERRE MUELLE	LOCK SPRING	4	4				
	Z442918000	CLIP CIERRE	LOCK SPRING	4	4				
10	J182102000	VÁLVULA PARA ACEITE	VALVE FOR OIL	1	2				
	J142106000	MANGUITO CONEXION GRIFO VAC.	MANGUITO CONEXION GRIFO VA	1	2				
	J142111000	JUNTA GRIFO VACIADO	JUNTA GRIFO VACIADO SNACK	1	2				
	J142110000	TOPE VALVULA	VALVE LIMIT	1	2				
10	J182108000	VÁLVULA DRENAJE CON TOPE	DRAIN VALVE WITH STOP	1	2				
	J182109000	CUERPO VÁLVULA DRENAJE	BODY DRAIN VALVE WITH STOP	1	2				
	J182104000	TUBO DRENAJE	DRAIN TUBE	1	2				
11	J142621000	GUÍA PANEL PORTAMANDOS	GUIDE PANEL OF CONTROLS	1	-				
11	J002610000	GUÍA PANEL PORTAMANDOS 400	400 GUIDE PANEL OF CONTROL	1	-				
11	J142624000	GUÍA PANEL PORTAMANDOS 600	GUIDE PANEL OF CONTROLS	-	1				
11	J002612000	GUÍA PANEL PORTAMANDOS 600	GUIDE PANEL OF CONTROLS	-	1				
	Q221342000	REMACHE EXAGONAL M5	HEXAGONAL RIVET M5	4	4				
	Q012031000	TORNILLO EXAGONAL M5x10 A304	HEXAGONAL BOLT M5x10 A304	4	4				

Зип Общепит

vsezip.ru

+7(812)987-18-81

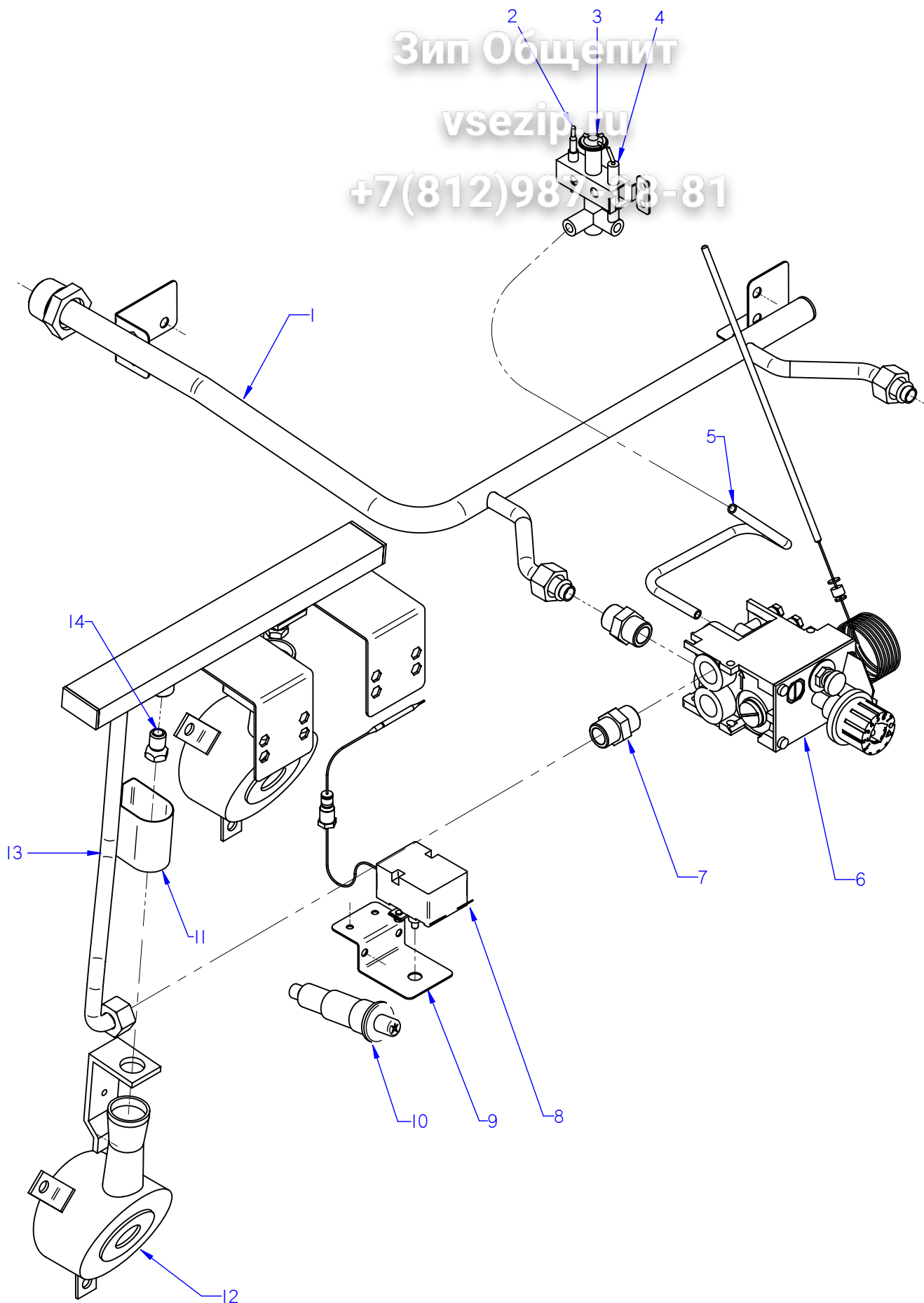

ITEM MARCADO EN COLOR = REPUESTO RECOMENDADO
COLOURED ITEM = RECOMMENDED SPARE PART

N plano	Firma	Fecha	Aparato	CONJUNTO FUNCIONAL	Lamina	Fagor Industrial S.Coop. FAGOR
C-2391	<i>[Signature]</i>	2009-06	FREIDORAS FG6-05 / FG6-10		2	Oñate

MOD.	FREIDORAS / FRYERS	ZONA	CONJUNTO FUNCIONAL / FUNCTIONAL U					
ITEM	CODIGO	DENOMINACION	TEXTO	FG6-05	FG6-10			
1	J145002000	ENTRADA GAS COMPL. FG6-05	COMPL. GAS INPUT FG6-05	1	—			
1	J145020000	ENTRADA GAS COMPL. FG6-10	COMPL. GAS INPUT FG6-10	—	1			
	Q012031000	TORNILLO EXAGONAL M5X10 A.304	HEXAGONAL BOLT M5X10 A.304	2	4			
	Q302022000	ARANDELA 16X6X1.2 A.304	WASHER 16X6X1.2 A.304	2	4			
	Q221342000	REMACHE EXAGONAL M5	HEXAGONAL RIVET M5	2	4			
	Q306062000	ARANDELA Ø13,9x10,33x1,5	WASHER Ø13,9x10,33x1,5	1	1			
2	S042106000	TERMOPAR MARMITAS BAÑO-MAR.	THERMOCOUPLE MG B-M	1	2			
3	U322118000	PILOTO COMPLETO 100.062	PILOT COMPL. 100.062	1	2			
	Q012031000	TORNILLO EXAGONAL M5X10 A.304	HEXAGONAL BOLT M5X10 A.304	2	4			
4	X022131000	BUJIA	SPARK PLUG	1	2			
5	J145012000	TUBO PILOTO FG6-05	PILOT PIPE FG6-05	1	—			
5	J145015000	TUBO PILOTO FG6-10	PILOT PIPE FG6-10	—	2			
S/Nº	U134323000	RACORD BICONO 6 958.031	BICONE CONNECTION 6 958.031	2	2			
6	J142105000	VALVULA 630 EUR 630.337	VALVE 630 EUR 630.337	1	2			
S/Nº	R662662000	JUNTA CIERRE BULBO LIMITADOR	CLOSE LIMIT BOARD BULB	1	2			
	Q011338000	TORNILLO EXAGONAL M5X60	HEXAGONAL BOLT M5X60	2	4			
S/Nº	J142605000	PROTECTOR VALVULA EUROSIT	EUROSIT PROTECTOR VALVE	1	—			
	Q012031000	TORNILLO EXAGONAL M5X10 A.304	HEXAGONAL BOLT M5X10 A.304	2	—			
	Q302022000	ARANDELA Ø16x63x1,2	WASHER Ø16x63x1,2	2	—			
7	R155068000	MANGUITO 3/8"	SLEEVE 3/8"	2	4			
	U264301000	RACORD EMPALME TERMOPAR	THERMOCOUPLE CONNECT.	2	4			
8	X163001000	TERMOSTATO LIMITADOR	THERMOSTAT LIMITER	1	2			
8	12048400	TERMOSTATO SEGURIDAD 245°C U	SECURITY THERMOSTAT 245 °	1	2			
9	J142618000	SOPORTE LIMITADOR	LIMITER SUPPORT	1	2			
	Q419005000	REMACHE 4X8 ALMG3 / ALUMINIO	RIVET 4X8 ALMG3 / ALUMINIUM	2	4			
10	S113034000	PIEZOELECTRICO	PIEZOELECTRIC	1	2			
10	12043897	PIEZOELECTRICO COMPLETO	COMPLETE PIEZOELECTRIC	1	2			
S/Nº	12043907	ANILLO ADAPTADOR	ADAPTER RING	1	2			
11	J145707000	REGULADOR DE AIRE	AIR REGULATOR	2	4			
	Q012031000	TORNILLO EXAGONAL M5X10 A.304	HEXAGONAL BOLT M5X10 A.304	2	4			
	Q302022000	ARANDELA 16X6X1.2 A.304	WASHER 16X6X1.2 A.304	2	4			

