

Зип Общепит

vsezip.ru

DESPIECE TECNICO

+7(812)987-08-81

Sarten basculante
Tilting Bratt Pan
Sauteuse basculante
Kippbratpfannen
Brasiere
Fritadeira baculante

GAMA 700

Modelos:

SBG7-10

SBE7-10

Junio 2008 June

Revisado Marzo 2014 March Revised

FAGOR 

F A G O R I N D U S T R I A L

NUEVA BISAGRA

Зип Общепит

vsezip.ru

+7(812)987-08-81

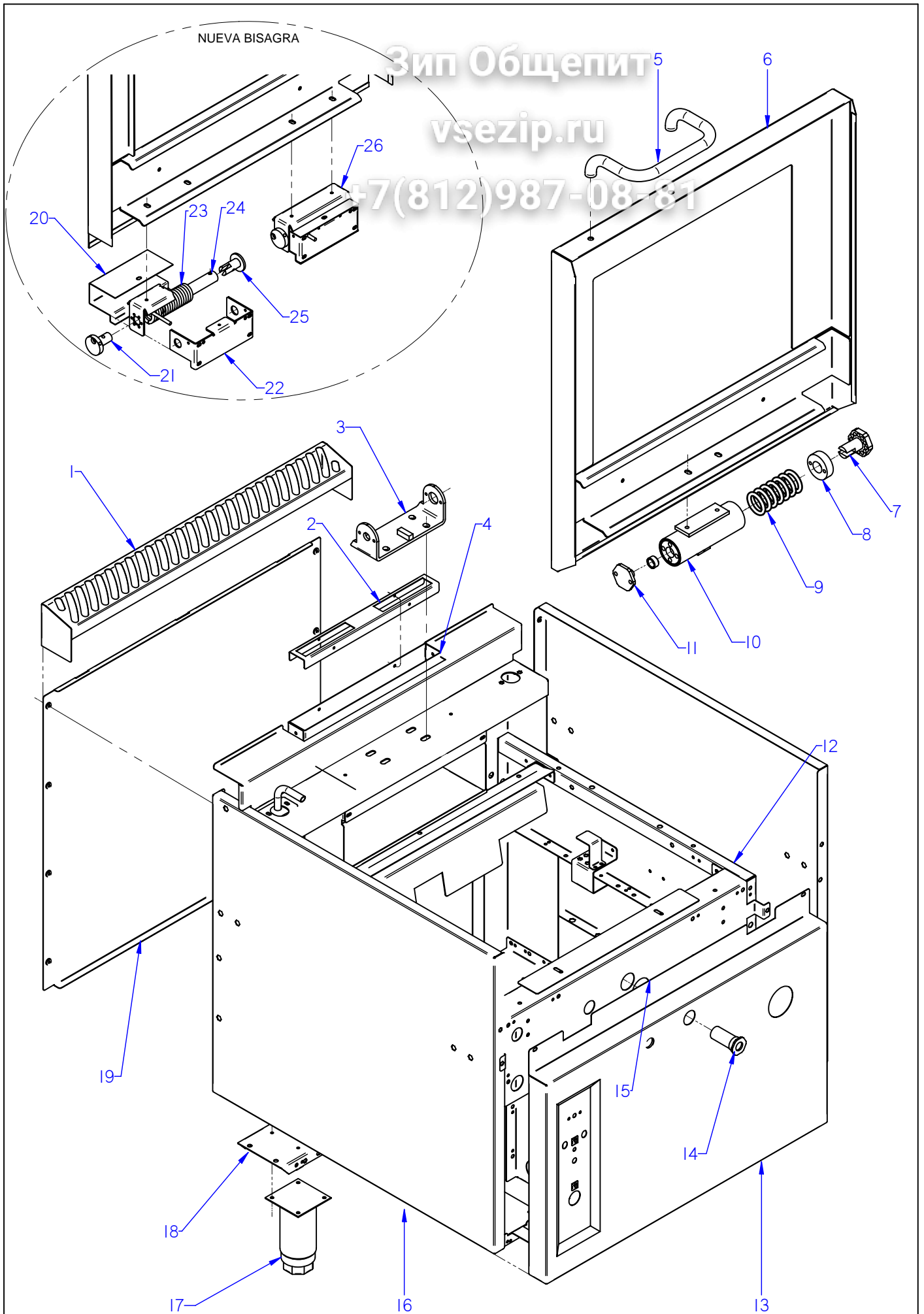

ITEM MARCADO EN COLOR = REPUESTO RECOMENDADO
COLOURED ITEM = RECOMMENDED SPARE PART

N plano	Firma	Fecha	Aparato	MUEBLE	Lamina	Fagor Industrial S.Coop. FAGOR
C-2095	<i>(Signature)</i>	2008-06	SARTEN BASCULANTE G-700		1	Oñate

MOD.	SARTEN BASCULANTE	ZONA vsezip.ru	MUEBLE
------	-------------------	----------------	--------

ITEM	CODIGO	DENOMINACION	TEXTO	SBG7-10	SBE7-10			
1	S565401000	EMBELLECEDOR POSTERIOR 1M	REAR TRIM 1M	1	1			
2	X262661000	FRENO DE CHIMENEA	FLUEPIPE BRAKE	1	-			
	Q419005000	REMACHE 4x8 ALMG3 / ALUMINIO	RIVET 4X8 ALMG3 / ALUMINIUM	4	-			
3	X286102000	SOPORTE BISAGRA COMPLETA	COMPLETE HINGE SUPPORT	1	1			
3	X086106000	SOPORTE BISAGRA COMPLETA	COMPLETE HINGE SUPPORT	1	1			
	Q012053000	TORNILLO EXAGONAL M8x20 A304	HEXAGONAL BOLT M8x20 A304	4	4			
	Q262050000	ARANDELA GROW. A8 A304	WASHER GROW. A8 A304	4	4			
	Q232050000	ARANDELA A8	WASHER A8	4	4			
	Q162050000	TUERCA EXAGONAL M8x1 INOX.	HEXAGONAL NUT M8x1 INOX.	4	4			
4	X262655000	ANTERIOR DE CHIMENEA	FLUEPIPE FRONT	1	-			
4	X262654000	POSTERIOR DE CHIMENEA	FLUEPIPE REAR	1	-			
	Q419005000	REMACHE 4x8 ALMG3 / ALUMINIO	RIVET 4X8 ALMG3 / ALUMINIUM	10	-			
	Q221342000	REMACHE EXAGONAL M5	HEXAGONAL RIVET M5	2	-			
4	X262658000	AMARRE CHIMENEA	FLUEPIPE FASTENING	2	-			
	Q012031000	TORNILLO EXAGONAL M5x10 A304	HEXAGONAL BOLT M5x10 A304	4	-			
	Q302022000	ARANDELA 16x6x1,2 A304	WASHER 16x6x1.2 A304	4	-			
5	S036123000	ASA DE TAPA	COVER HANDLE	1	1			
	X152809000	SUJECCION ASA DE TAPA	COVER HANDLE FASTENING	2	2			
	Q302027000	ARANDELA 25X8,4X2	WASHER 25X8.4X2	2	2			
6	X462808000	TAPA COMPLETA SARTEN G-700	COMPLETE FRYPAN COVER G-700	1	1			
6	X266124000	TAPA COMPLETA SARTEN G-700	COMPLETE FRYPAN COVER G-700	1	1			
	Q012051000	TORNILLO EXAGONAL M8x10	HEXAGONAL BOLT M8x10	2	2			
7	S116120000	TENSOR MUELLE	TENSIONING SPRING	1	1			
	Q012042000	TORNILLO EXAGONAL M6x15	HEXAGONAL BOLT M6x15	2	2			
	Q262040000	ARANDELA GROW. A6 A304	WASHER GROW. A6 A304	2	2			
8	S116118000	CASQUILLO	BUSHING	1	1			
9	S116121000	RESORTE TAPA 07199	SPRING COVER 07199	1	1			
9	S316110000	MUELLE BISAGRA	SPRING HINGE	2	2			
10	X156101000	BISAGRA COMPLETA	COMPLETE HINGE	1	1			
	S116126000	COJINETE CILINDRICO	CYLINDRICAL BEARING	1	1			

MOD.		SARTEN BASCULANTE		ZONA vsezip.ru		MUEBLE		
ITEM	CODIGO	DENOMINACION	TEXTO	SBG7-10	SBE7-10			
11	S116119000	GIRO DE ASA	HANDLE ROTATION	1	1			
	Q012041000	TORNILLO EXAGONAL M6x10 A304	HEXAGONAL BOLT M6x10 A304	2	2			
12	X460114000	ARMAZON COMPL. SARTEN G-700	COMPL. FRYPAN FRAME G-700	1	1			
13	X462803000	PANEL FRONTAL SBG-710	FRONT PANEL SBG-710	1	-			
13	X482801000	PANEL FRONTAL SBE-710	FRONT PANEL SBE-710	-	1			
	Q152004000	TORN. APLASTADO M5x13 A304	HEXAGONAL FLAT SCREW M5x13	2	2			
	Q012042000	TORNILLO EXAGONAL M6x15	HEXAGONAL BOLT M6x15	2	2			
	Q262040000	ARANDELA GROW. A6 A304	WASHER GROW. A6 A304	2	2			
14	R982606000	EMBELLECEDOR TUBO	PIPE TRIM	1	-			
15	X460108000	PANEL SUPERIOR G-750Q	UPPER PANEL G-750Q	1	1			
	Q221342000	REMACHE EXAGONAL M5	HEXAGONAL RIVET M5	4	4			
	Q411304000	REMACHE AVIBULB Ø4,8	AVIBULB RIVET Ø4.8	10	10			
16	X462804000	PANEL LATERAL IZDO. SBG7-10	LEFT SIDE PANEL SBG7-10	1	1			
	Q221343000	REMACHE EXAGONAL M6	HEXAGONAL RIVET M6	11	11			
	Q302022000	ARANDELA 16X6X1.2 A.304	WASHER 16X6X1.2 A.304	4	4			
	Q262040000	ARANDELA GROW. A6 A304	WASHER GROW. A6 A304	4	4			
	Q221342000	REMACHE EXAGONAL M5	HEXAGONAL RIVET M5	1	1			
	Q152004000	TORN. APLASTADO M5x13 A304	HEXAGONAL FLAT SCREW M5x13	1	1			
S/Nº	X462805000	PANEL LATERAL DCHO. SBG7-10	RIGHT SIDE PANEL SBG7-10	1	1			
	Q221343000	REMACHE EXAGONAL M6	HEXAGONAL RIVET M6	11	11			
	Q302022000	ARANDELA 16X6X1.2 A.304	WASHER 16X6X1.2 A.304	4	4			
	Q262040000	ARANDELA GROW. A6 A304	WASHER GROW. A6 A304	4	4			
	Q221342000	REMACHE EXAGONAL M5	HEXAGONAL RIVET M5	1	1			
	Q152004000	TORN. APLASTADO M5x13 A304	HEXAGONAL FLAT SCREW M5x13	1	1			
17	X260151000	PATA REGULABLE	ADJUSTABLE LEG	4	4			
	Q411304000	REMACHE AVIBULB Ø 4,8	AVIBULB RIVET Ø 4.8	16	16			
18	X260152000	LISTON SOPORTE PATAS	LEG SUPPORT STRIP	2	2			
	Q221342000	REMACHE EXAGONAL M5	HEXAGONAL RIVET M5	4	4			
	Q221343000	REMACHE EXAGONAL M6	HEXAGONAL RIVET M6	2	2			
19	S562805000	PANEL POSTERIOR G750	REAR PANEL G750	1	1			
	Q419005000	REMACHE 4x8 ALMG3 / ALUMINIO	RIVET 4X8 ALMG3 / ALUMINIUM	8	8			

MOD.		SARTEN BASCULANTE		ZONA		MUEBLE		
ITEM	CODIGO	DENOMINACION	TEXTO	SBG7-10	SBE7-10			
20	X266125000	PROTECTOR BISAGRA SARTEN	HINGE PROTECTOR	2	2			
21	X266129000	TAPA AMARRE SARTEN G700	MOORING COVER PAN G700	2	2			
22	X266121000	SOPORTE BISAGRA COMPLETA	COMPLETE HINGE SUPPORT	2	2			
23	X266126000	MUELLE BISAGRA Ø5,5	SPRING HINGE Ø5,5	2	2			
24	X266128000	EJE BISAGRA SARTEN 700	PAN HINGE SHAFT 700	2	2			
25	X266130000	TAPA CIERRE SARTEN	CLOSING COVER PAN	2	2			
26	X266120000	BISAGRA COMPLETA	COMPLETE HINGE	2	2			

Зип Общепит

vsezip.ru

+7(812)987-08-81

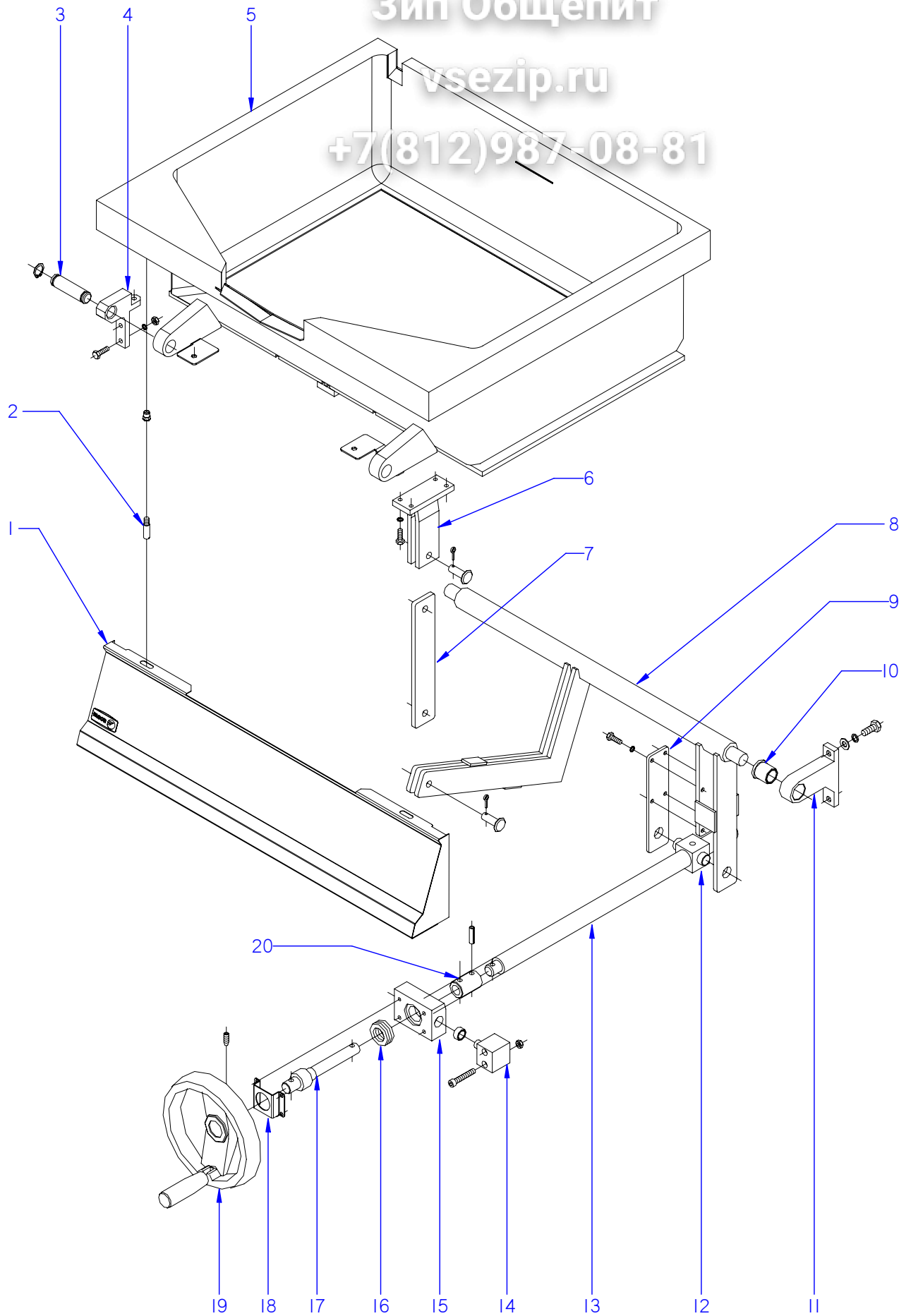

ITEM MARCADO EN COLOR = REPUESTO RECOMENDADO
COLOURED ITEM = RECOMMENDED SPARE PART

N plano	Firma	Fecha	Aparato	CUBA	Lamina	Fagor Industrial S.Coop. FAGOR
C-2096	<i>(Signature)</i>	2008-06	SARTEN BASCULANTE G-700		2	Oñate

Зип Общепит

MOD.	SARTEN BASCULANTE	ZONA	CUBA
-------------	--------------------------	-------------	-------------

ITEM	CODIGO	DENOMINACION	TEXTO	SBG7-10	SBE7-10		
1	X462802000	PORTAMANDOS COMP. SBG/E7-10	COMP. CONTROL HOLDER SBG/E	1	1		
	U912805000	ESCUDO FAGOR G700	FAGOR EMBLEM G700	1	1		
	Q221023000	CLIP SUJECIÓN RÁPIDA Ø5	RAPID CONNECT CLIP Ø5	2	2		
	Q012042000	TORN. EXAGONAL M6X15 AISI 304	HEXAGONAL BOLT M6X15 AISI 304	2	2		
	Q301304000	ARANDELA PLANA 23X6.5X2	FLAT WASHER 23X6.5X2	2	2		
2	Q151336000	TORNILLO SOPORTE GUIAS	GUIDE SUPPORT BOLT	2	2		
3	X466107000	BULON GIRO-SARTEN	FRYPAN-ROTATION PIN	2	2		
	Q301020000	ANILLO DE SEGURIDAD 20x1,2	CIRCLIP 20x1.2	4	4		
4	X156145000	SOPORTE GIRO CUBA	TUB ROTATION SUPPORT	2	2		
	Q012043000	TORNILLO EXAGONAL M6x20 A304	HEXAGONAL BOLT M6x20 A304	6	6		
	Q262040000	ARANDELA GROW. A6 A304	WASHER GROW. A6 A304	6	6		
	Q162040000	TUERCA EXAGONAL M6	HEXAGONAL NUT M6	6	6		
5	X466102000	CUBA INOX. SBG-710 / SBE-710	INOX. TUB SBG-710 / SBE-710	1	-		
5	X486101000	SARTEN SBE-710 C/PERNOS	FRYPAN SBE-710 WITH PINS	-	1		
	Q221343000	REMACHE EXAGONAL M6	HEXAGONAL RIVET M6	2	2		
	Q221343000	REMACHE EXAGONAL M6	HEXAGONAL RIVET M6	2	2		
6		BRAZO DE GIRO	ROTATION ARM	1	1		
	X156123000	BULON Ø12	PIN Ø12	2	2		
	Q352024000	PASADOR DE ALETAS Ø4x25	COTTER PIN Ø4x25	2	2		
7	X266116000	BRAZO GAMA-700	ARM RANGE -700	1	1		
8	X466113000	BRAZO ELEVADOR COMPL.G-700	ELEVATOR ARM COMPL.G-700	1	1		
9	X156149000	BRAZO LATERAL	SIDE ARM	1	1		
	Q012042000	TORNILLO EXAGONAL M6x15	HEXAGONAL BOLT M6x15	4	4		
	Q262040000	ARANDELA GROW. A6 A304	WASHER GROW. A6 A304	4	4		
10	X109550000	COJINETE SELFOIL B11	BEARING SELFOIL B11	2	2		
11	X150108000	SOPORTE DE GIRO	ROTATION SUPPORT	2	2		
	Q012063000	TORNILLO EXAG. M10x20 A304	HEX BOLT M10x20 A304	4	4		
	Q261060000	ARANDELA MUELLE A10	SPRING WASHER A10	4	4		
	Q232060000	ARANDELA A10	WASHER A10	4	4		
12	X466116000	TUERCA HUSILLO G-700	SPINDLE NUT G-700	1	1		
	Q011364000	TORNILLO EXAG. M10x25 A304	HEX BOLT M10x25 A304	4	4		

Зип Общепит

MOD.	SARTEN BASCULANTE	vsezip.ru	CUBA
-------------	--------------------------	------------------	-------------

ITEM	CODIGO	DENOMINACION	TEXTO	SBG7-10	SBE7-10			
13	X266111000	(X266119) HUSILLO GAMA 700	(X266119) SPINDLE RANGE 700	1	1			
S/Nº	X466117000	TUERCA + HUSILLO G-700	SPINDLE + NUT G-700	1	1			
S/Nº	12046641	TUERCA + HUSILLO Tr26x5 G700	SPINDLE + NUT Tr26x5 G700	1	1			
14	X156113000	PIVOTE DE GIRO	ROTATION PIVOT	2	2			
	Q052046000	TORNILLO ALLEN M6x40 A304	ALLEN BOLT M6x40 A304	4	4			
	Q162040000	TUERCA EXAGONAL M6	HEXAGONAL NUT M6	4	4			
15	X156114000	SOPORTE RODAMIENTO	BEARING SUPPORT	1	1			
	S116126000	COJINETE CILINDRICO	CYLINDRICAL BEARING	2	2			
16	X156125000	RODAMIENTO 51204	BEARING 51204	1	1			
17	X156161000	EJE VOLANTE COMPLETO	COMPLETE FLYSHAFT	1	1			
18	X152619000	SOPOTE EJE VOLANTE	FLYSHAFT SUPPORT	1	1			
	Q012041000	TORNILLO EXAGONAL M6x10 A304	HEXAGONAL BOLT M6x10 A304	4	4			
	Q262040000	ARANDELA GROW. A6 A304	WASHER GROW. A6 A304	4	4			
19	X156139000	VOLANTE ELESA	FLYSHAFT ELESA	1	1			
	Q131552000	VARILLA ROSCADA M8x15	THREADED ROD M8X15	2	2			
20	X156115000	CASQUILLO	BUSHING	1	1			
	Q371027000	MANGUITO DE SUJECCION Ø8x30	FASTENING SLEEVE Ø8x30	2	2			

Зип Общепит

vsezip.ru

+7(812)987-08-81

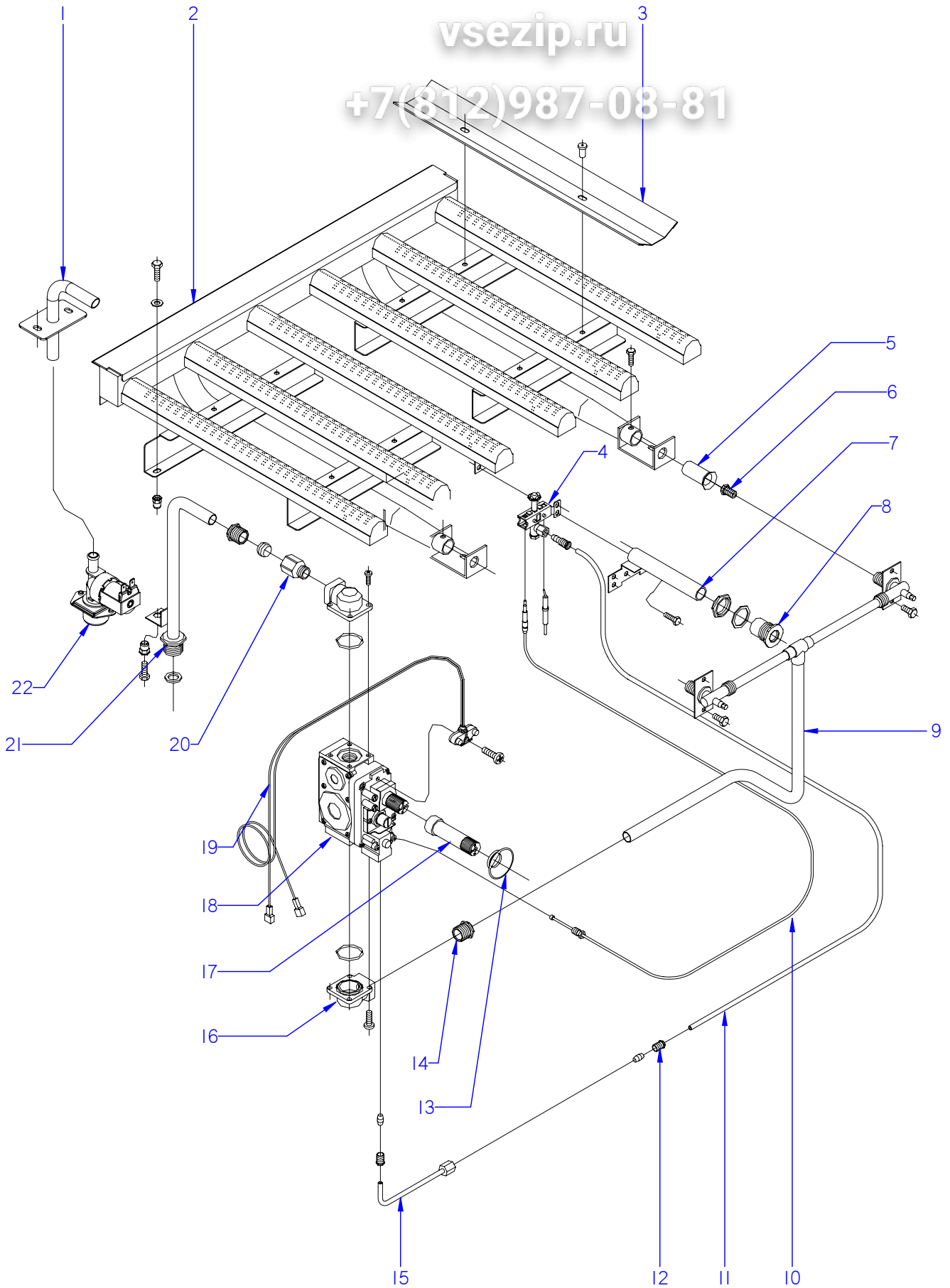

ITEM MARCADO EN COLOR = REPUESTO RECOMENDADO
COLOURED ITEM = RECOMMENDED SPARE PART

N plano	Firma	Fecha	Aparato	PARTE FUNCIONAL DE GAS	Lamina	Fagor Industrial S.Coop. FAGOR
C-2097	<i>(Signature)</i>	2008-06	SARTEN BASCULANTE SBG7-10		3	Oñate

MOD.		SARTEN BASCULANTE		ZONA		PARTE FUNCIONAL GAS			
ITEM	CODIGO	DENOMINACION	TEXTO	SBG7-10					
1	X466119000	CONJUNTO TUBO LLENADO CR	FILLER PIPE ASSEMBLY CR	1					
	Q152004000	TORN. APLASTADO M5x13 A304	HEXAGONAL FLAT SCREW M5x13	2					
S/Nº	3676900000	TUBO GOMA NEGRA D 17*10	BLACK RUBBER PIPE 17*10	1					
	Q881308000	ABRAZADERA 8-14L	CLAMP 8-14L	2					
2	X265722000	QUEMADOR COMPLETO SBG-710	COMPLETE BURNER SBG-710	1					
3	X265709000	DEFLECTOR LARGO G 700	LONG DEFLECTOR G 700	4					
	Q419005000	REMACHE 4x8 ALMG3 / ALUMINIO	RIVET 4X8 ALMG3 / ALUMINIUM	8					
4	U322118000	PILOTO COMPLETO 100.062	COMPLETE PILOT LIGHT 100.062	1					
	Q012031000	TORNILLO EXAGONAL M5x10 A304	HEXAGONAL BOLT M5x10 A304	2					
	Q162030000	TUERCA EXAGONAL M5	HEXAGONAL NUT M5	2					
	U442137000	INYECTOR Ø 0,40 GN	INJECTOR Ø 0.40 GN.	1					
	X022131000	BUJIA	SPARK PLUG	1					
5	U325707000	REGULADOR DE AIRE	AIR REGULATOR	2					
	Q012031000	TORNILLO EXAGONAL M5x10 A304	HEXAGONAL BOLT M5x10 A304	4					
6	U052402000	TOBERA Ø 1,30 (Butano-Propano)	NOZZLE Ø1.30 (BUT-PROP.)	2					
6	9429500000	TOBERA Ø 1,90 (Gas Natural)	NOZZLE Ø1.90 (NATURAL GAS)	2					
7	X155035000	TUBO DE ENCENDIDO COMPLETO	COMPLETE IGNITION PIPE	1					
8	R982606000	EMBELLECEDOR TUBO	PIPE TRIM	1					
	Q221324000	TUERCA 3/4 GAS	NUT 3/4 GAS	1					
	Q306027000	ARANDELA PLANA 33.8X27X1.5	FLAT WASHER 33.8X27X1.5	1					
9	X265020000	CONDUCC. QUEMADOR SBG-710	BURNER PIPE SBG-710	1					
	Q012031000	TORNILLO EXAGONAL M5x10 A304	HEXAGONAL BOLT M5x10 A304	4					
	Q302022000	ARANDELA 16x6x1,2 A304	WASHER 16x6x1.2 A304	4					
	Q306057000	ARANDELA Ø18x12,5x1,5	WASHER Ø18x12.5x1.5	1					
	Q153002000	TORNILLO TAPON	CAP BOLT	2					
10	U562130000	TERMOPAR L=850	THERMOCOUPLE L=850	1					
11	X265016000	TUBO PILOTO	PILOT PIPE	1					
11	X265023000	TUBO PILOTO	PILOT PIPE	1					
	U134323000	RACORD BICONO Ø6 958.031	BICONE CONNEX Ø6 958.031	2					
12	U195009000	MANGUITO EMPALME	CONNECTION HOSE	1					
	X205028000	BICONO Ø6	BICONE Ø6	1					

Зип Общепит

MOD.	SARTEN BASCULANTE		ЗЦНА	PARTE FUNCIONAL GAS			
ITEM	CODIGO	DENOMINACION	TEXTO	SBG7-10			
13	X152121000	JUNTA VALVULA	VALVE GASKET	1			
14	S205023000	MANGUITO DOBLE 1/2	DOUBLE SLEEVE 1/2	1			
15	X155043000	TUBO PILOTO A VALVULA COMPL.	PILOT PIPE TO COMPLETE VALVE	1			
16	X153004000	CODO 1-2 820 NOV 906.260	L-PIPE 1-2 820 NOV 906.260	2			
17	X262100000	ALARGADERO NEG. 999.975	BLACK EXTENSION 999.975	1			
18	12097292	VALVULA NOVA 820 REGULADA	VALVE REGULATED NOVA 820	1			
18	12024777	ELECTROVALV. 820 NOVA 60 Hz.	SOLENOID VALVE. 820 NOVA 60	1			
	Q012031000	TORNILLO EXAGONAL M5x10 A304	HEXAGONAL BOLT M5x10 A304	2			
	Q302022000	ARANDELA 16x6x1,2 A304	WASHER 16x6x1.2 A304	2			
19	R275027000	CABLEADO ELECTROSIT 927.012	WIRING ELECTROSIT 927.012	1			
20	X162101000	RACORD 1/2	CONNECTION 1/2	1			
	X012105000	BICONO Ø 16 957.008	BICONE Ø 16,957.008	1			
	X012104000	MANGUITO 1/2 958.027	HOSE 1/2 958.027	1			
21	X265012000	CONDUCCION ENTRADA COMPL.	COMPL. INPUT PIPE	1			
	Q221343000	REMACHE EXAGONAL M6	HEXAGONAL RIVET M6	1			
	Q012042000	TORNILLO EXAGONAL M6x15	HEXAGONAL BOLT M6x15	1			
	Q302022000	ARANDELA 16x6x1,2 A304	WASHER 16x6x1.2 A304	1			
22	Z701135000	E.V.SIMP.220V COD.255.208	E.V.SIMP.220V COD.255.208	1			
	Z601156000	REGULADOR 8L RO. 254.034	REGULATOR 8L RED 254.034	1			
	12096626	REGULADOR 8 L (ROJO)	REGULATOR 8L RED	1			

Зип Общепит

vsezip.ru

+7(812)987-08-81

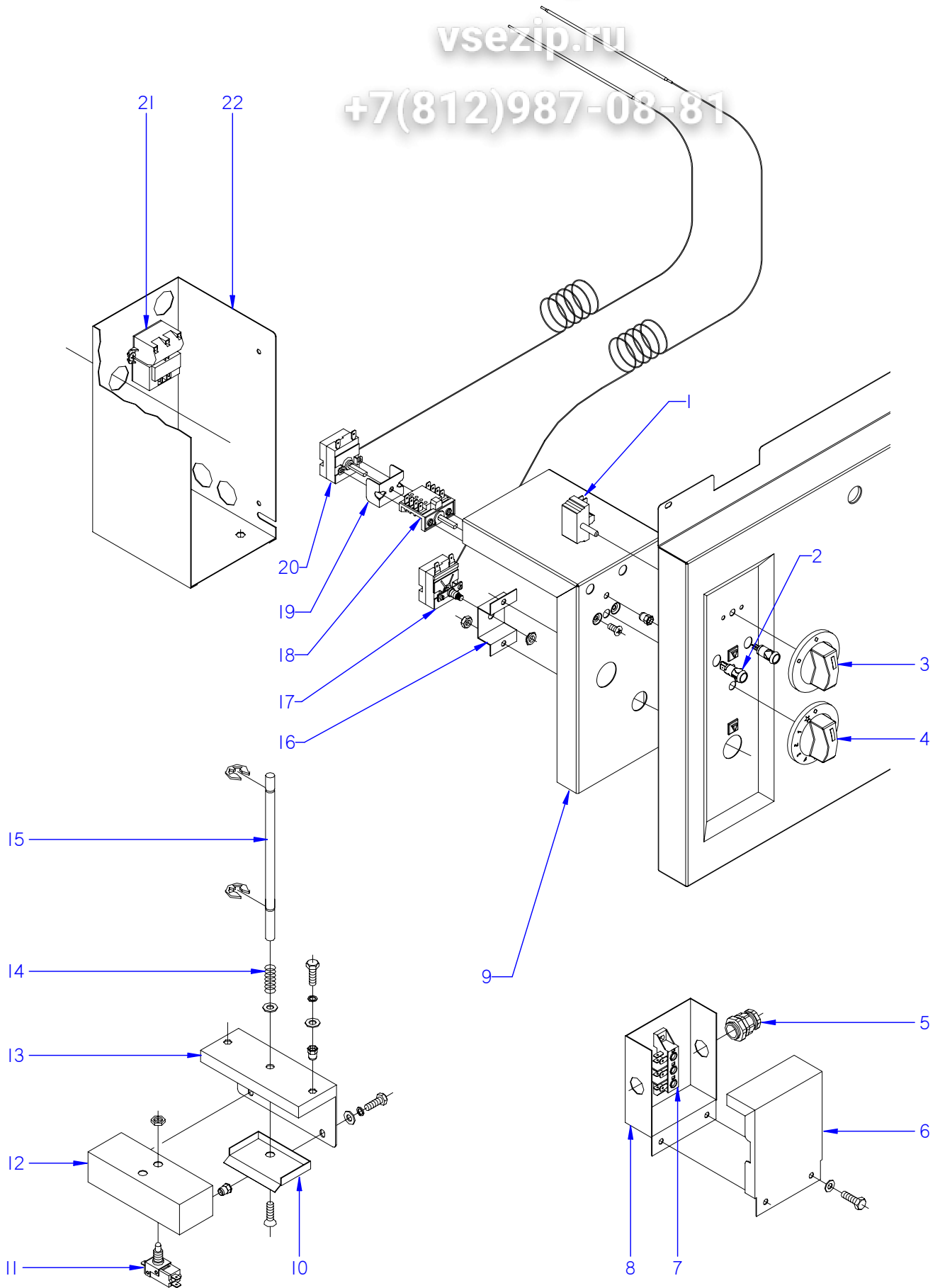

ITEM MARCADO EN COLOR = REPUESTO RECOMENDADO
COLOURED ITEM = RECOMMENDED SPARE PART

N plano	Firma	Fecha	Aparato	PARTE FUNCIONAL ELECTRICA	Lamina	Fagor Industrial S.Coop. FAGOR
C-2098	<i>(Signature)</i>	2008-06	SARTEN BASCULANTE SBG7-10		4	Oñate

Зип Общепит

MOD.	SARTEN BASCULANTE	ZCNA	PARTE FUNCIONAL ELECTRICA
-------------	--------------------------	------	----------------------------------

ITEM	CODIGO	DENOMINACION	TEXTO	SBG7-10				
1	T343008000	CONMUTADOR HGC	HGC SWITCH	1				
	Q151320000	TOR. ALOMADO M4X6 H.ZINCADO	CURVED SCREW M4X6 H. ZINC	2				
2	X143017000	PILOTO VERDE SARTEN	GREEN FRYPAN PILOT	1				
2	12047390	PILOTO VERDE 230V AC 8KW 16MM	GREEN PILOT 230V AC 8KW 16MM	1				
	X143018000	PILOTO AMBAR SARTEN	FRYING PAM AMBER PILOT	1				
	12024669	PILOTO AMBAR Ø18	AMBER PILOT Ø18	1				
3	H212103000	BOTON DE MANDO Ø6 (EN. AGUA)	CONTROL BUTTON Ø6 (WATER II	1				
4	X462101000	BOTON DE MANDO Ø6 SBG7-10	CONTROL BUTTON Ø6 SBG7-10	1				
5	R073004000	PRENSA ESTOPAS	STUFFING BOX	2				
	R073025000	CONTRATUERCA (GAES) 790.1300.0	COUNTERNUT (GAES) 790.1300.0	2				
	R073026000	JUNTA DE GOMA (GAES)	RUBBER SEAL (GAES)	2				
6	X342600000	TAPA CAJA REGLETA	STRIP BOX COVER	1				
7	U183046000	REGLETA AUXILIAR	AUXILIARY STRIP	1				
8	X342601000	CUADRO REGLETA	STRIP PANEL	1				
	Q012042000	TORNILLO EXAGONAL M6x15	HEXAGONAL BOLT M6x15	2				
	Q302022000	ARANDELA 16x6x1,2 A304	WASHER 16x6x1.2 A304	2				
9	X152667000	TAPA CAJA SOPORTE VALVULA	VALVE SUPPORT BOX COVER	1				
10	X152646000	PROTECCION SUPERIOR	UPPER PROTECTION	1				
	Q152024000	TORNILLO AVELLANADO M4x8 A304	COUNTERSUNK BOLT M4X8 A304	1				
11	X343015000	MICRORRUPTOR 32280001	MICROSWITCH 32280001	1				
11	X022138000	MICRORRUPTOR 250V AC 16A VDE	MICROSWITCH 250V AC 16A VDE	1				
12	X152681000	CAJA PORTA MICRO	MICRO HOLDER BOX	1				
	Q221342000	REMACHE EXAGONAL M5	HEXAGONAL RIVET M5	2				
13	X152680000	SOPORTE CAJA PORTA MICRO	MICRO HOLDER BOX SUPPORT	1				
	Q221342000	REMACHE EXAGONAL M5	HEXAGONAL RIVET M5	2				
	Q012031000	TORNILLO EXAGONAL M5x10 A304	HEXAGONAL BOLT M5x10 A304	2				
	Q302022000	ARANDELA 16x6x1,2 A304	WASHER 16x6x1.2 A304	2				
	Q262030000	ARANDELA GROW. A5 A304	WASHER GROW. A5 A304	2				
14	Z700603000	MUELLE 07777	SPRING 07777	1				
15	X152682000	EJE PULSADOR MICRO	MICRO BUTTON SHAFT	1				
	Q271033000	ARANDELA DE SEGURIDAD Ø6	SAFETY WASHER Ø6	2				

Зип Общепит

MOD.		SARTEN BASCULANTE	ZCNA	PARTE FUNCIONAL ELECTRICA				
ITEM	CODIGO	DENOMINACION	TEXTO	SBG7-10				
16	X152661000	SOPORTE LIMITADOR	LIMITER SUPPORT	1				
	Q162030000	TUERCA EXAGONAL M5	HEXAGONAL NUT M5	2				
17	R612103000	TERMOSTATO LIMITADOR	THERMOSTAT LIMITER	1				
	Q013023000	TORNILL. EXAGONAL M4x20 LATON	HEXAGONAL BOLT M4X20 BRASS	1				
	Q163020000	TUERCA EXAGONAL M4 LATON	HEXAGONAL NUT M4 BRASS	1				
	Q183001000	TUERCA CUADRADA M4	SQUARE NUT M4	1				
	Q563004000	LENGÜETA COMPONENTES DOBLE	DOUBLE COMPONENTS TONGUE	1				
	Z603022000	PLACA ASIEN TO CONEXIÓN MASA	SEATING PLATE EARTH CONNEC	1				
18	X163007000	CONMUTADOR ACOPLE TERMOS	THERMOSTAT CONNECT SWITCH	1				
19	X313001000	"U" SOPORTE TERMOSTATO	THERMOSTAT U SUPPORT	1				
20	X153000000	TERMOSTATO 50-310 C	THERMOSTAT 50-310 C	1				
	Q042021000	TORNILL. AVELLANADO M4x10 A304	COUNTERSUNK BOLT M4X10 A304	2				
21	X163014000	ENCENDEDOR 2 BUJIAS	LIGHTER 2 SPARK PLUG	1				
	Q082005000	TORNILLO CHAP.4,2X13 4.2X13	PLATE BOLT .4.2X13 4.2X13	2				
22	X152656000	SOPORTE VALVULA	VALVE SUPPORT	1				
	Q411304000	REMACHE AVIBULB Ø 4,8	AVIBULB RIVET Ø 4.8	4				
	Q221342000	REMACHE EXAGONAL M5	HEXAGONAL RIVET M5	2				

Зип Общепит

vsezip.ru

+7(812)987-08-81

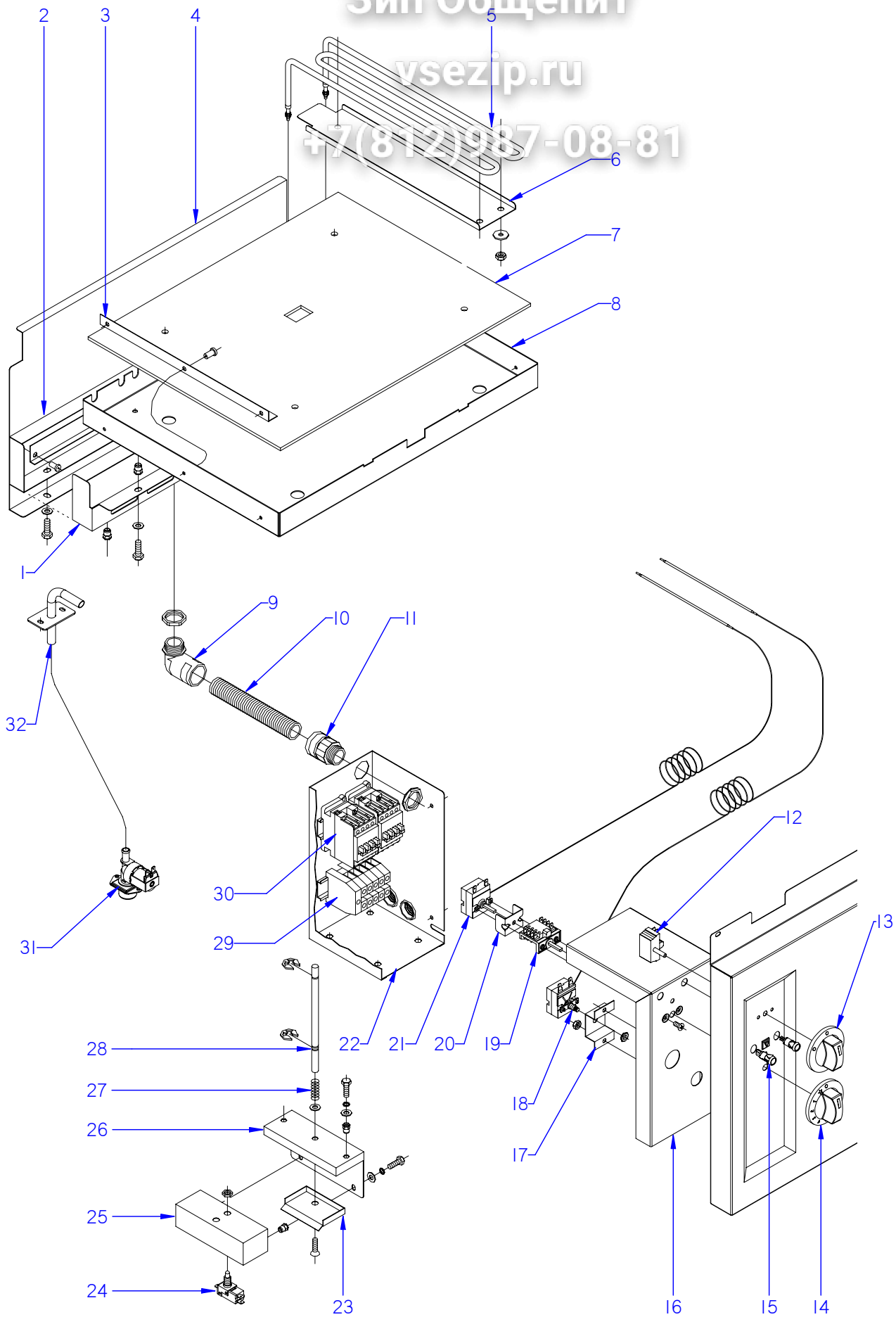

ITEM MARCADO EN COLOR = REPUESTO RECOMENDADO
COLOURED ITEM = RECOMMENDED SPARE PART

N plano	Firma	Fecha	Aparato	PARTE FUNCIONAL	Lamina	Fagor Industrial S.Coop. FAGOR
C-2099	<i>[Signature]</i>	2008-06	SARTEN BASCULANTE SBE7-10		5	Oñate

Зип Общепит

MOD.		SARTEN BASCULANTE		vsezip.ru		PARTE FUNCIONAL	
ITEM	CODIGO	DENOMINACION	TEXTO	SBE7-10			
1	X272618000	CUBIERTA BORNAS SBE-710	TERMINAL COVER SBE-710	1			
	Q012032000	TORNILLO EXAGONAL M5x15 A304	HEXAGONAL BOLT M5x15 A304	3			
	Q262030000	ARANDELA GROW. A5 A304	WASHER GROW. A5 A304	3			
	Q221342000	REMACHE EXAGONAL M5	HEXAGONAL RIVET M5	5			
2	X272619000	TAPA CUBIERTA BORNAS SBE-710	TERMINAL COVER LID SBE-710	1			
	X272612000	ESCUADRA SEPARADOR RESIST.	RESIST. DIVIDER BRACKET	1			
	Q012032000	TORNILLO EXAGONAL M5x15 A304	HEXAGONAL BOLT M5x15 A304	5			
	Q262030000	ARANDELA GROW. A5 A304	WASHER GROW. A5 A304	5			
	Q419005000	REMACHE 4x8 ALMG3 / ALUMINIO	RIVET 4X8 ALMG3 / ALUMINIUM	3			
3	X272603000	AMARRE AISLANTE	INSULATION FASTENING	3			
4	X272616000	PROTECCION AGUA A BORNAS	WATER PROTECTION TO TERMIN	1			
5	X273000000	RESISTENCIA 230V. 1500W. SBE-7	RESISTOR 230V 1500W SBE-7	6			
6	X272607000	AMARRE RESISTENCIAS	RESISTOR FASTENING	6			
	Q162040000	TUERCA EXAGONAL M6	HEXAGONAL NUT M6	18			
	Q301304000	ARANDELA PLANA Ø23x6,5x2	FLAT WASHER Ø23x6.5x2	18			
7	X272617000	AISLANTE 570X400X5	INSULATION 570X400X5	1			
8	X272620000	CUBIERTA RESISTENC. SBE-710	RESISTOR COVER SBE-710	1			
	Q221342000	REMACHE EXAGONAL M5	HEXAGONAL RIVET M5	7			
9	Z703006000	RACORD A 90 SFWO-P213T	CONNECTION A 90 SFWO-P213T	1			
	X143012000	CONTRATUERCA PG21 GAESTOP.	COUNTERNUT PG21 GAESTOP.	1			
10	3712300000	TUBO PG21 0233.204.023	PIPE PG21 0233.204.023	1			
11	X713021000	RACORD ICK 5020	CONNECTION ICK 5020	1			
12	T343008000	CONMUTADOR HGC	HGC SWITCH	1			
	Q151320000	TORN. ALOMADO M4X6 H.ZINCADO	HEXAGONAL CURVED HEAD M4X	2			
13	H212103000	BOTON DE MANDO Ø6 (EN. AGUA)	CONTROL BUTTON Ø6 (WATER II	1			
14	X482101000	BOTON DE MANDO Ø6 G-750Q	CONTROL BUTTON Ø6 G-750Q	1			
15	X143017000	PILOTO VERDE SARTEN	GREEN FRYPAN PILOT	1			
15	12047390	PILOTO VERDE 230V AC 8KW 16MM	GREEN PILOT 230V AC 8KW 16MM	1			
	X143018000	PILOTO AMBAR SARTEN	FRYING PAM AMBER PILOT	1			
	12024669	PILOTO AMBAR Ø18	AMBER PILOT Ø18	1			
16	X152667000	TAPA CAJA SOPORTE VALVULA	VALVE SUPPORT BOX COVER	1			

Зип Общепит

vsezip.ru

ZONA

PARTE FUNCIONAL

MOD.

SARTEN BASCULANTE

+7(812)987-08-81

ITEM	CODIGO	DENOMINACION	TEXTO	SBE7-10				
17	X152661000	SOPORTE LIMITADOR	LIMITER SUPPORT	1				
	Q162030000	TUERCA EXAGONAL M5	HEXAGONAL NUT M5	2				
18	R612103000	TERMOSTATO LIMITADOR	THERMOSTAT LIMITER	1				
	Q013023000	TORNILL. EXAGONAL M4x20 LATON	HEXAGONAL BOLT M4X20 BRASS	1				
	Q163020000	TUERCA EXAGONAL M4 LATON	HEXAGONAL NUT M4 BRASS	1				
	Q183001000	TUERCA CUADRADA M4	SQUARE NUT M4	1				
	Q563004000	LENGÜETA COMPONENT. DOBLE	DOUBLE COMPONENT TONGUE	1				
	Z603022000	PLACA ASIENTO CONEXIÓN MASA	SEATING PLATE EARTH CONNEC	1				
19	X163007000	CONMUTADOR ACOPLA TERMOS	THERMOSTAT CONNECT SWITCH	1				
20	X313001000	"U" SOPORTE TERMOSTATO	THERMOSTAT U SUPPORT	1				
21	X153000000	TERMOSTATO 50-310 C	THERMOSTAT 50-310 C	1				
	Q042021000	TORNIL. AVELLANADO M4x10 A304	COUNTERSUNK BOLT M4X10 A304	2				
22	X152656000	SOPORTE VALVULA	VALVE SUPPORT	1				
	X723014000	PASAMUROS DIAMETRO 30	WALL BUSHING DIAMETER 30	3				
	Q411304000	REMACHE AVIBULB Ø 4,8	AVIBULB RIVET Ø 4.8	4				
23	X152646000	PROTECCION SUPERIOR	UPPER PROTECTION	1				
	Q152024000	TORNILLO AVELLANADO M4x8 A304	COUNTERSUNK BOLT M4X8 A304	1				
24	X343015000	MICRORRUPTOR 32280001	MICROSWITCH 32280001	1				
24	X022138000	MICRORRUPTOR 250V AC 16A VDE	MICROSWITCH 250V AC 16A VDE	1				
25	X152681000	CAJA PORTA MICRO	MICRO HOLDER BOX	1				
	Q221342000	REMACHE EXAGONAL M5	HEXAGONAL RIVET M5	2				
26	X152680000	SOPORTE CAJA PORTA MICRO	MICRO HOLDER BOX SUPPORT	1				
	Q221342000	REMACHE EXAGONAL M5	HEXAGONAL RIVET M5	2				
	Q012031000	TORNILLO EXAGONAL M5x10 A304	HEXAGONAL BOLT M5x10 A304	2				
	Q302022000	ARANDELA 16x6x1,2 A304	WASHER 16x6x1.2 A304	2				
	Q262030000	ARANDELA GROW. A5 A304	WASHER GROW. A5 A304	2				
27	Z700603000	MUELLE 07777	SPRING 07777	1				
28	X152682000	EJE PULSADOR MICRO	MICRO BUTTON SHAFT	1				
	Q271033000	ARANDELA DE SEGURIDAD Ø6	SAFETY WASHER Ø6	2				

Зип Общепит

MOD.	SARTEN BASCULANTE			vsezip.ru	PARTE FUNCIONAL					
ITEM	CODIGO	DENOMINACION	TEXTO	SBE7-10						
29	P453025000	BORNES 10 WDU-10203.O	TERMINALS 10 WDU-10203.O	3						
	Z263302000	BORNA DE PASO AZUL	BLUE THROUGH TERMINAL	1						
	P453026000	BORNE TIER 10 WPE-10103.O	TERMINAL TIER 10 WPE-10103.O	1						
	Z263303000	TOPE FINAL	END STOP	1						
	R663055000	GUIA CONTACTOR L-120	CONTACTOR GUIDE L-120	1						
	Q419005000	REMACHE 4x8 ALMG3 / ALUMINIO	RIVET 4X8 ALMG3 / ALUMINIUM	2						
30	Z203050000	CONTAC. SIRIUS 3R 230V.50-60	CONTACT. SIRIUS 3R 230V.50-60	2						
	R663055000	GUIA CONTACTOR L-120	CONTACTOR GUIDE L-120	1						
	Q419005000	REMACHE 4x8 ALMG3 / ALUMINIO	RIVET 4X8 ALMG3 / ALUMINIUM	2						
31	Z701135000	E.V.SIMP.220V COD.255.208	E.V.SIMP.220V COD.255.208	1						
	Z601156000	REGULADOR 8L RO. 254.034	REGULATOR 8L RED 254.034	1						
	12096626	REGULADOR 8 L (ROJO)	REGULATOR 8L RED	1						
	Q032021000	TORNILLO ALOMADO M4X10	CURVED SCREW M4X10	2						
32	X466119000	CONJUNTO TUBO LLENADO CR	FILLER PIPE ASSEMBLY CR	1						
	Q152004000	TORN. APLASTADO M5x13 A304	HEXAGONAL FLAT SCREW M5x13	2						
S/Nº	3676900000	TUBO GOMA NEGRA D 17*10	BLACK RUBBER PIPE 17*10	1						
	Q881308000	ABRAZADERA 8-14L	CLAMP 8-14L	2						

MOD.		SARTEN BASCULANTE		ZONA	VARIOS			
ITEM	CODIGO	DENOMINACION	TEXTO	SBG7-10	SBE7-10			
	X026501000	FOLLETO DE INSTRUCCION. SBG	INSTRUCTION LEAFLET SBG	1				
	X046501000	FOLLETO DE INSTRUCCION. SBE	INSTRUCTION LEAFLET SBE		1			
	X463002000	ESQUEMA TEORICO SBG7-10	THEORETICAL DIAGRAM SBG7-	1				
	X343023000	ESQUEMA TEORICO	THEORETICAL DIAGRAM	1				
	X483002000	ESQUEMA TEORICO SBE7-10	THEORETICAL DIAGRAM SBE7-		1			
	X403002000	ESQUEMA TEORICO	THEORETICAL DIAGRAM		1			
	X463004000	PLANO DE MONTAJE SBG7-10	ASSEMBLY PLAN SBG7-10	1				
	X483003000	PLANO DE MONTAJE SBE7-10	ASSEMBLY PLAN SBE7-10		1			
	X463007000	LEYENDA SARTEN BASCULANTE	BOILING PAN LEGEND	1	1			
	X153021000	INSTALACION ELECTRICA	ELECTRIC INSTALLATION	1				
	U333003000	CABLE MASA ENCENDEDOR	LIGHTER EARTH CABLE	1				
	U323007000	CABLE ENCENDEDOR A BUJIA	LIGHTER TO SPARK PLUG CABLE	1				
	X163002000	CABLE BUJIA	SPARK PLUG CABLE	1				
	X463003000	CABL. ELECTROVALVULA SBG7-10	SOLENOID VALVE CABLE. SBG7	1				
	X483004000	CABL. ELECTROVALVULA SBE7-10	SOLENOID VALVE CABLE. SBE7		1			
	X143015000	CABLEADO SBE	WIRING SBE		1			
	X143004000	CABLEADO RESISTENCIAS	RESISTOR WIRING		1			
	X143016000	CABLEAD. REGLETA CONTACTOR	WIRING CONTACTOR STRIP		2			
	X463006000	CABLEADO ENTRADA DE AGUA SB	WATER INPUT WIRING SB	1	1			

MOD.	SARTEN BASCULANTE	ZONA vsezip.ru	REPUESTOS RECOMENDADOS RECOMMENDED SPARE PART
-------------	--------------------------	--------------------------	----------------------------------------------------------------

ITEM	CODIGO	DENOMINACION	TEXTO	SBG7-10	SBE7-10			
23	X266126000	MUELLE BISAGRA Ø5,5	SPRING HINGE Ø5,5	2	2			
20	X156115000	CASQUILLO	BUSHING	1	1			
4	U322118000	PILOTO COMPLETO 100.062	COMPLETE PILOT LIGHT 100.062	1				
	U442137000	INYECTOR Ø 0,40 GN	INJECTOR Ø 0.40 GN.	1				
	X022131000	BUJIA	SPARK PLUG	1				
16	X153004000	CODO 1-2 820 NOV 906.260	L-PIPE 1-2 820 NOV 906.260	2				
17	X262100000	ALARGADERO NEG. 999.975	BLACK EXTENSION 999.975	1				
18	12097292	VALVULA NOVA 820 REGULADA	VALVE REGULATED NOVA 820	1				
18	12024777	ELECTROVALV. 820 NOVA 60 Hz.	SOLENOID VALVE. 820 NOVA 60 H	1				
19	R275027000	CABLEADO ELECTROSIT 927.012	WIRING ELECTROSIT 927.012	1				
22	Z701135000	E.V.SIMP.220V COD.255.208	E.V.SIMP.220V COD.255.208	1				
1	T343008000	CONMUTADOR HGC	HGC SWITCH	1				
2	12047390	PILOTO VERDE 230V AC 8KW 16MM	GREEN PILOT 230V AC 8KW 16MM	1				
	12024669	PILOTO AMBAR Ø18	AMBER PILOT Ø18	1				
11	X022138000	MICRORRUPTOR 250V AC 16A VDE	MICROSWITCH 250V AC 16A VDE	1				
17	R612103000	TERMOSTATO LIMITADOR	THERMOSTAT LIMITER	1				
18	X163007000	CONMUTADOR ACOPLE TERMOS	THERMOSTAT CONNECT SWITCH	1				
20	X153000000	TERMOSTATO 50-310 C	THERMOSTAT 50-310 C	1				
5	X273000000	RESISTENCIA 230V. 1500W. SBE-7	RESISTOR 230V 1500W SBE-7		6			
12	T343008000	CONMUTADOR HGC	HGC SWITCH		1			
15	12047390	PILOTO VERDE 230V AC 8KW 16MM	GREEN PILOT 230V AC 8KW 16MM		1			
	12024669	PILOTO AMBAR Ø18	AMBER PILOT Ø18		1			
18	R612103000	TERMOSTATO LIMITADOR	THERMOSTAT LIMITER		1			
19	X163007000	CONMUTADOR ACOPLE TERMOS	THERMOSTAT CONNECT SWITCH		1			
21	X153000000	TERMOSTATO 50-310 C	THERMOSTAT 50-310 C		1			
24	X022138000	MICRORRUPTOR 250V AC 16A VDE	MICROSWITCH 250V AC 16A VDE		1			
31	Z701135000	E.V.SIMP.220V COD.255.208	E.V.SIMP.220V COD.255.208		1			

SBG 910, 710, 915 M, 910 M

+7(812)987-08-81

230 V 1N 50/60 Hz

IGV	1 1a	2 2a	3 3a	4 4a	5 5a	6 6a
0						
1	X	X			X	X
2	X	X		X		X
3	X	X	X	X		

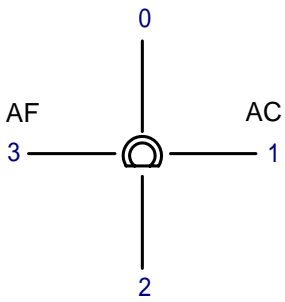

mod.
AD

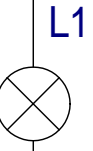
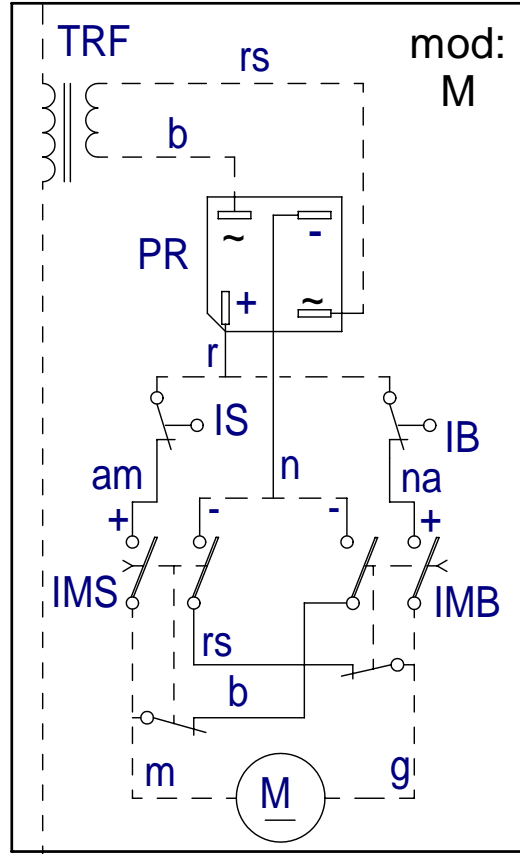
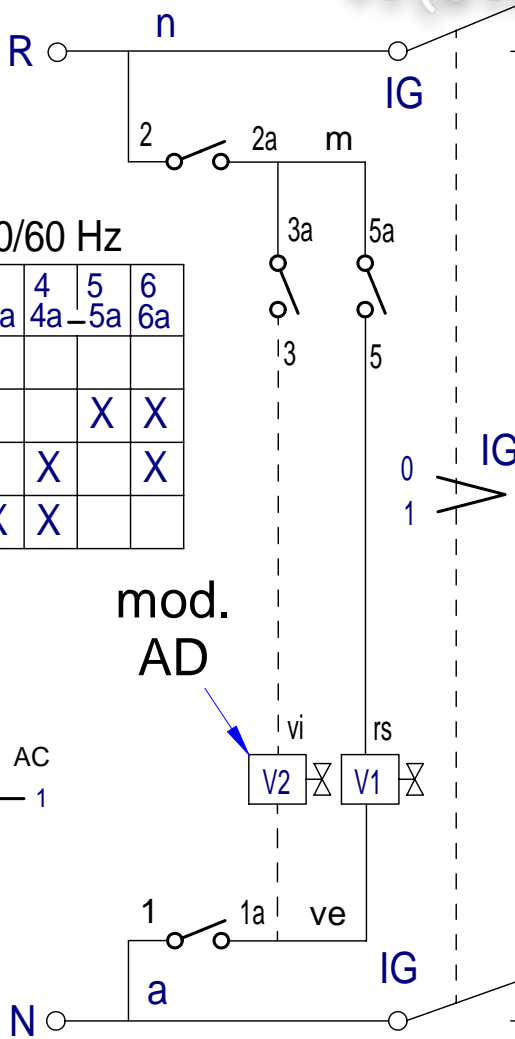

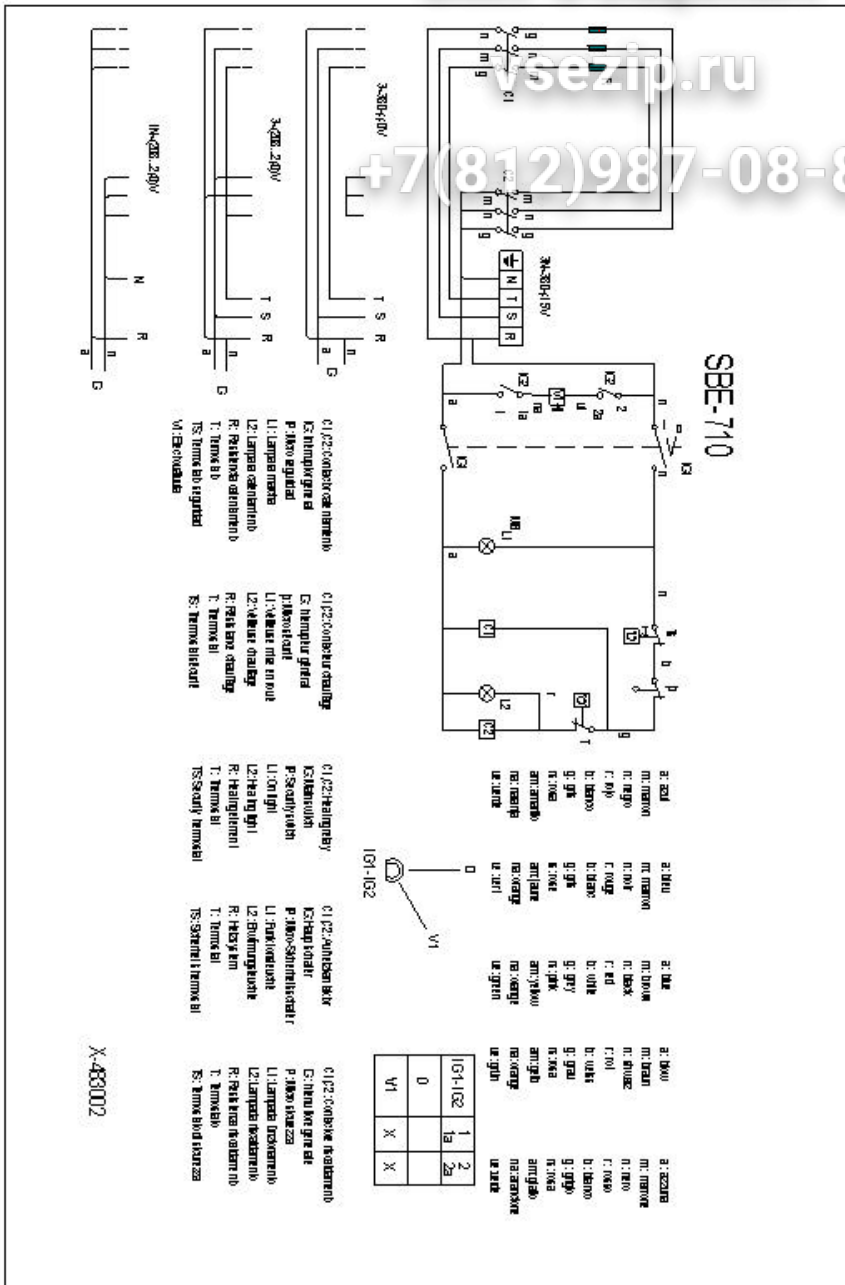

X-483002

Esquema teórico SBE		
Nº	Plaza	
Nº	Modificación	
Elaborado		Fecha
Dibujado		J. Etxeberria 30-11-2002
Proyectado		J. Etxeberria 30-11-2002
Comprobado		J. Etxeberria
Escala		
SARTI		

Зип Общепит

vsezip.ru

+7(812)987-08-81

IGV	1 1a	2 2a	3 3a	4 4a	5 5a	6 6a
0						
1	X	X			X	X
2	X	X		X		X
3	X	X	X	X		

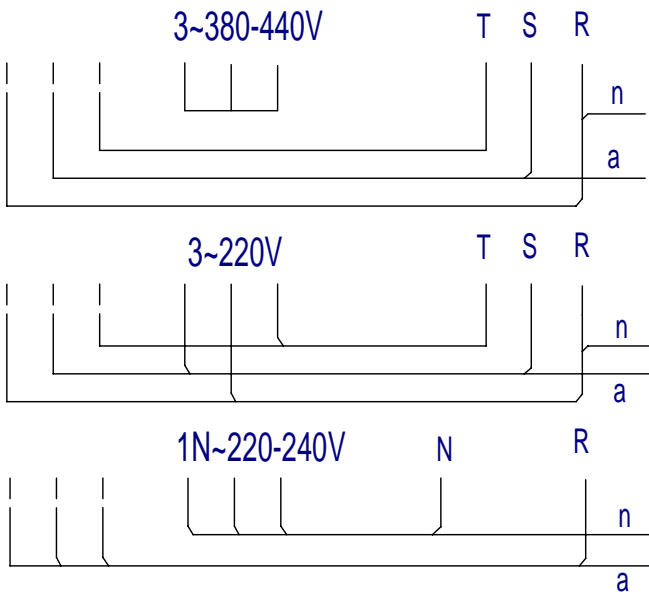
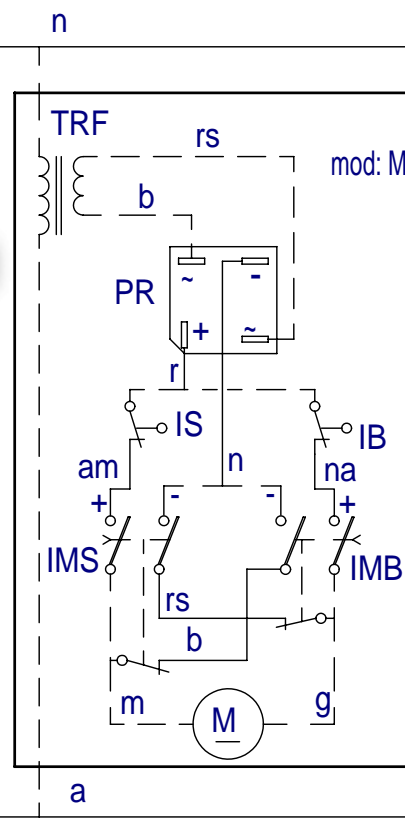
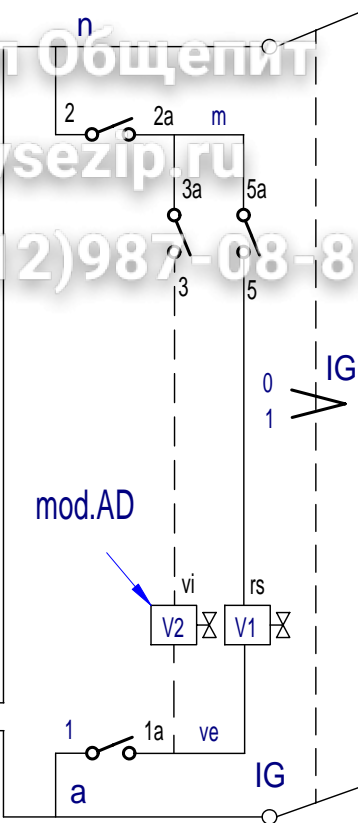
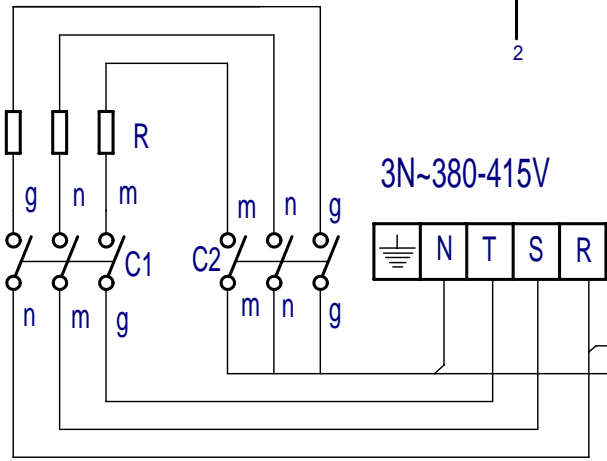

SBE 710,
910 M, 915

Зип Общепит

vsezip.ru

+7(812)987-08-81

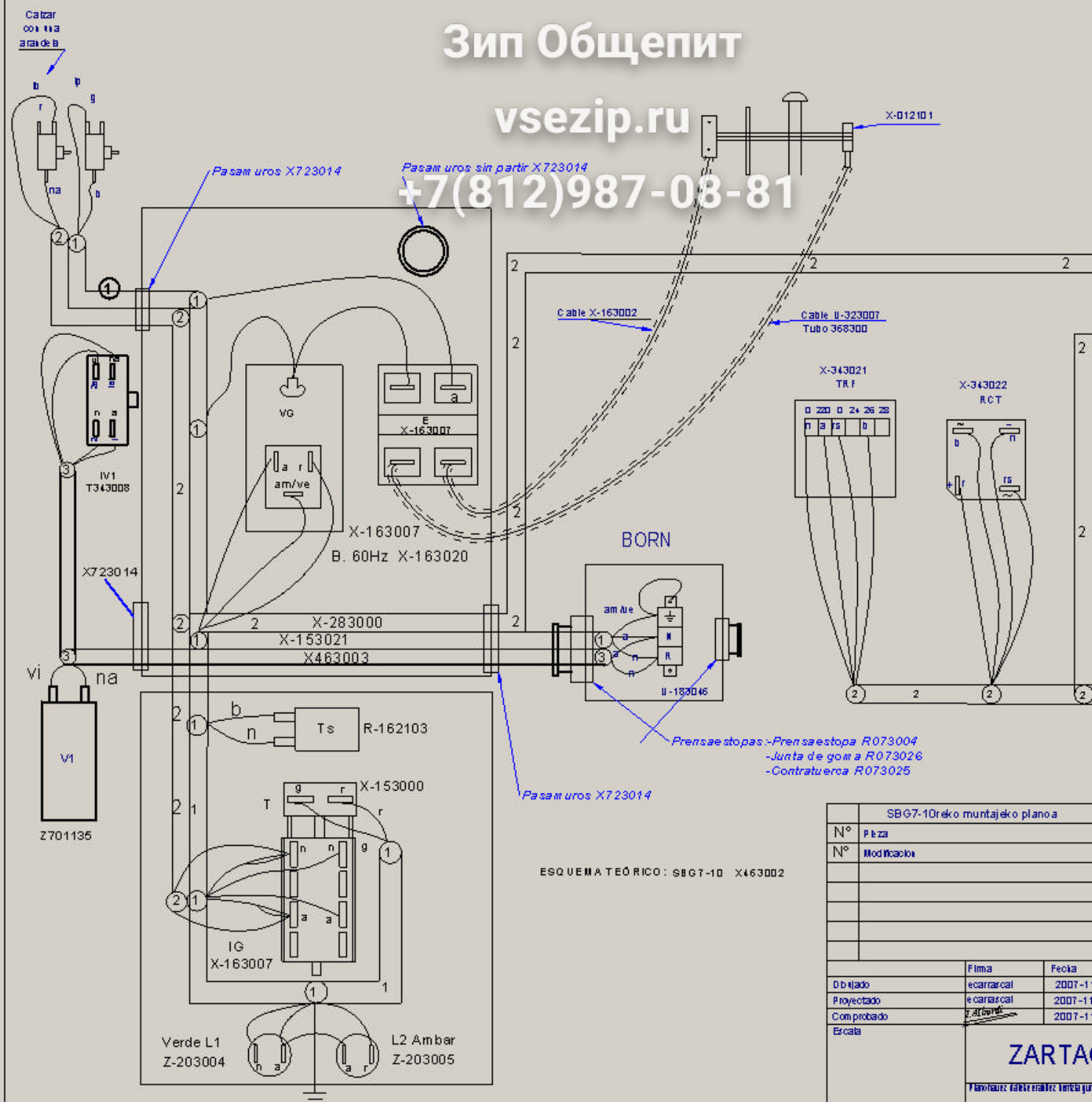

Cablear con una arañada

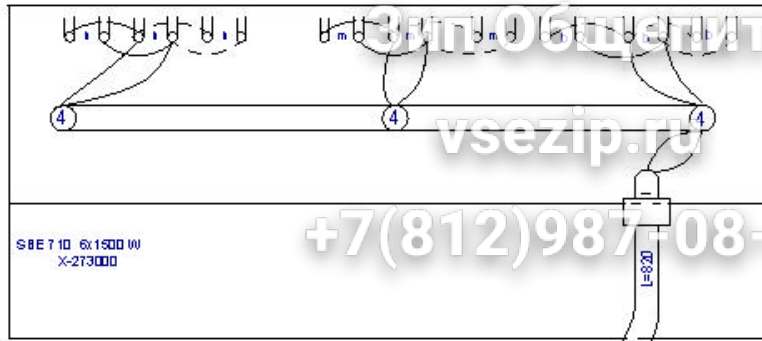

Instalación	SBE7-10
1	X143015
2	X283000
3	X143016
4	X143004
5	X483004

+7(812)987708-81

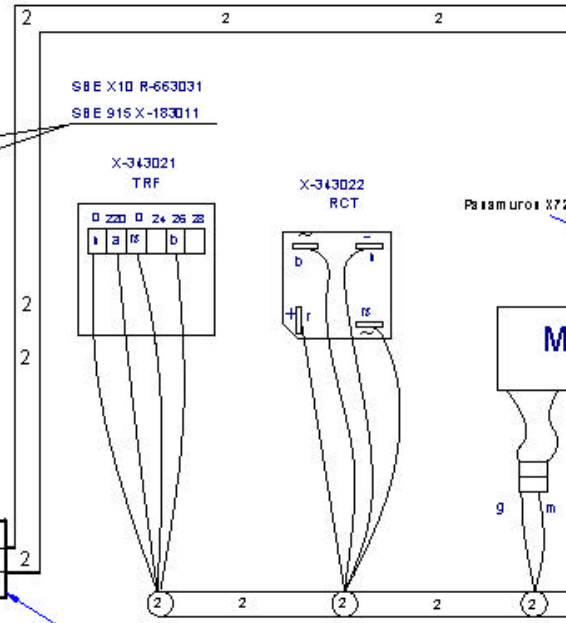
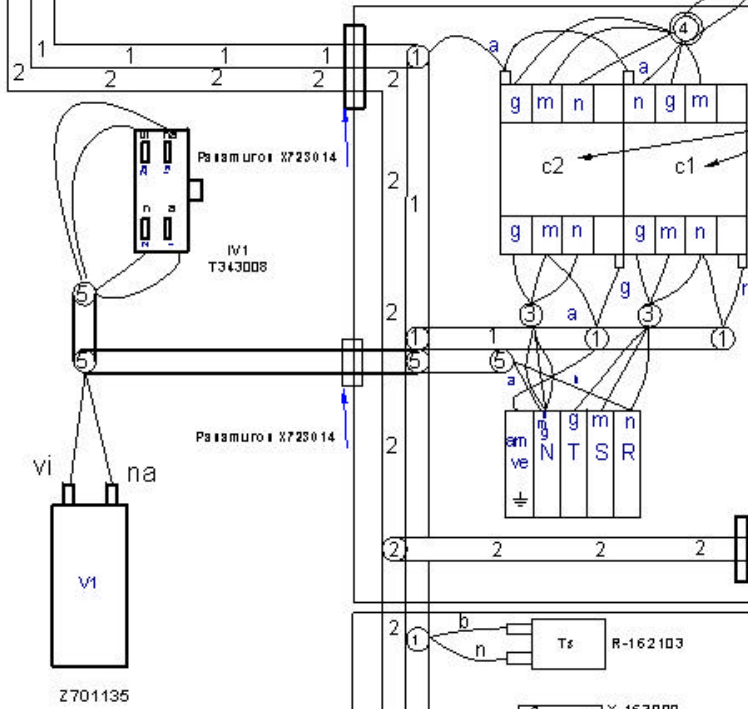

Presillas tipo P-Preisaestopa R033002
-Junta de goma R033026
-Contratiebica R033025

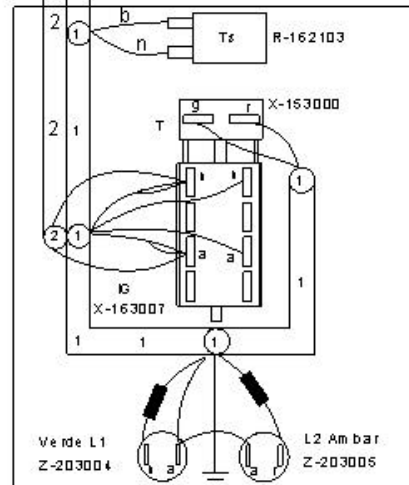

SGE7-10reko muntajeko plano a		
Nº	Pieza	
Nº	Modifikazioa	
Diseñado	Elmascual	2007-11-
Proyectado	ecarrascal	2007-11-
Comprobado	<i>J. Garcia</i>	2007-11-
Escala		
ZARTAG		
Para hacer cables entre los bloques		

Зип Общежит

Simb/LENG	ESPAÑOL	ENGLISH	FRENCH	DEUTSCH
C1, C2	= Contactor Calentamiento	Contacteur Chauffe	Heating Contactor	Heizschütz
CN	= Control de Nivel de agua	Control of water Level	Commande de niveau d'eau	Steuerung des Wasserspiegels
E	= Generador de Chispa	Spark generator	Générateur d'étincelle	Funkengenerator
IB	= Micro tope bajada	Microswitch of lowered Limit	Microcontact de la limite abaissée	Mikroschalter der gesenkten Begrenzung
IG	= Interruptor general	General switch	Commutateur général	Allgemeiner Schalter
IGV	= Interruptor electrovalvas de agua	Switch electrovalvula water	Commutez l'eau d'electrovalvula	Schalten Sie electrovalvula Wasser
IE	= Pulsador de Encendido	Ignition Switch	Commutateur d'allumage	Zündung-Schalter
IMB	= Pulsador bajada	lowered switch	commutateur abaisse	gesenkter Schalter
IMS	= Pulsador subida	Raised switch	Commutateur augmenté	Angehobener Schalter
IP	= Micro seguridad	security microswitch	microcontact de sécurité	Sicherheitsmikroschalter
IS	= Micro tope subida	Microswitch of rise Limit	Microcontact de la limite d'élévation	Mikroschalter der Aufstieg Begrenzung
L1	= Lámpara marcha	Operation Light	Lumière d'opération	Betriebs-Licht
L2	= Lámpara calentamiento	Heating Light	Lumière de chauffage	Heizungs-Licht
M	= Motor de elevacion	Motor of elevation	Moteur d'altitude	Motor des Aufzugs
P	= Presostato de Camara	Water Level Switch	Commutateur de niveau d'eau	Wasserspiegel-Schalter
PR	= Puente rectificador	Electrical bridge rectifier	Pont redresseur électrique	Elektrischer Brückengleichrichter
R	= Resistencia Calentamiento.	Résistance Chauffe	Heating Resistors	Widerstand Aufheizung
RE	= Regulador Energia	Regulator of Energy	Régulateur d'énergie	Regler von Energie
T	= Termostato	Thermostat	Thermostat	Thermostat
TRF	= Transformador	Transformer	Transformateur	Transformator
TS	= Termostato de seguridad	Security Thermostat	Thermostat de sécurité	Sicherheits-Thermostat
TRP	= Termopar	Thermocouple	Thermocouple	Thermoelement
VG1,VG2	= ElectroVálvula gas	Electrical gas valve	Clapet à gaz électrique	Elektrisches Gichtventil
V1	= Valvula Agua CALIENTE	ElectroValve of Hot Water	Électrovalve d'eau chaude	Elektroventil des Heißwassers
V2	= Valvula Agua FRIA	ElectroValve of cold Water	Électrovalve d'eau froide	Elektroventil des kalten Wassers
V3	= Valvula Agua Caldera	electrovalve of water boiler	électrovalve de chauffe-eau	Elektroventil des Warmwasserboilers
	= COLORES	COLOUR	COULEURS	FARBEN
a	= Azul	Blue	Bleu	Blau
am	= Amarillo	Yellow	Jaune	Gelb
am/ve	= Amarillo/verde	Yellow / green	Jaune / vert	Gelb/grün
b	= Blanco	White	Blanc	Weiß
g	= Gris	Grey	Gris	Grau
m	= Marrón	Brown	Marron	Braun
n	= Negro	Black	Noir	Schwarz
na	= Naranja	Orange	Orange	Orange
r	= Rojo	Red	Rouge	Rot
rs	= Rosa	Pink	Rose	Rosa
ve	= Verde	Green	Vert	Grün
vi	= Violeta	Purple	Violet	Violett