

Зип Общепит

vsezip.ru

DESPIECE TECNICO

+7(812)987-08-81

**Cocinas a gas todo plancha  
Gas ranges with solid top  
Fourneaux plaque coup de feu à gaz  
Gas-herde mit glühplatte  
Cucine tuttapiastra a gas  
Fogão a gás todo em placa**

**GAMA 900**

**Modelos:**

**CG9-10**

**CG9-11**

**CGE9-11**

***Junio 2009 June***

***Revisado Mayo 2014 May Revised***

**FAGOR** 

FAGOR INDUSTRIAL

Зип-Общепит

vsezip.ru

+7(812)987-08-81

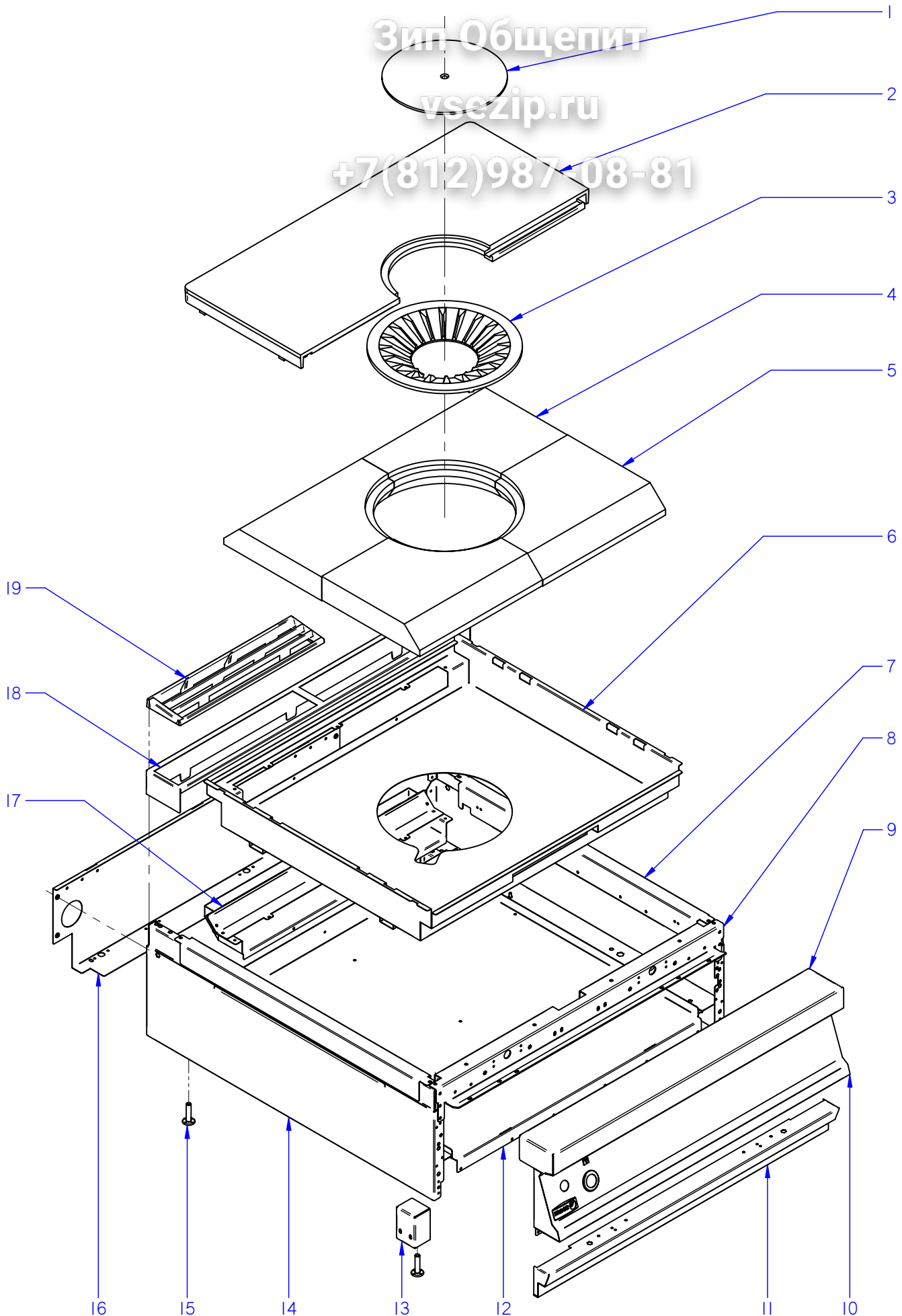

ITEM MARCADO EN COLOR = REPUESTO RECOMENDADO  
COLOURED ITEM = RECOMMENDED SPARE PART

N plano	Firma	Fecha	Aparato	MUEBLE	Lamina	Fagor Industrial S.Coop. <b>FAGOR</b>
C-2350	<i>(Signature)</i>	2009-06	COCINA CG9-10		1	Oñate

MOD.		COCINAS		ZONA		MUEBLE / UNIT			
ITEM	CODIGO	DENOMINACION	TEXTO	CG9-10					
1	U195421000	RODELA	GUIDE RING	1					
2	U025412000	MEDIA PLACA G900	MEDIUM PLATE G900	2					
3	U195420000	RODELA DIFUSORA FG-8	DISPENSER GUIDE RING FG-8	1					
4	U615408000	REFRACTARIO DERECHO	RIGHT REFRACTORY	2					
5	U615407000	REFRACTARIO IZQUIERDO	LEFT REFRACTORY	2					
6	U615464000	CAJON REFRACTARIO	REFRACTORY DRAWER	1					
7	R062810000	PANEL LATERAL DERECHO G900	RIGHT SIDE PANEL G900	1					
	Q221342000	REMACHE EXAGONAL M5	HEXAGONAL RIVET M5	9					
	Q221343000	REMACHE EXAGONAL M6	HEXAGONAL RIVET M6	1					
8	U022632000	ESCUA INTER AMARRE ANTE 1 M	BRACKET INTER FASTE. FRONT	1					
	Q221342000	REMACHE EXAGONAL M5	HEXAGONAL RIVET M5	4					
	Q012032000	TORNILLO EXAGONAL M5x15	HEXAGONAL BOLT M5x15	6					
9	S105402000	ANTERIOR MESA 1 M	BENCH FRONT 1 M	1					
	Q152004000	TORNIL, APLASTADO M5x13 A304	FLAT HEADED BOLT M5x13 A304	2					
	Q302022000	ARANDELA 16x6x1,2 A304	WASHER 16x6x1.2 A304	2					
10	U022858/000	PORTAMANDOS COMPL. CG9-10	CONTROL HOLDER CG9-10	1					
	U022836000	ESCUDO FAGOR	FAGOR EMBLEM	1					
	Q221023000	CLIP SUJECIÓN RÁPIDA Ø5	RAPID CONNECT CLIP Ø5	2					
	Q152004000	TORNIL, APLASTADO M5x13 A304	FLAT HEADED BOLT M5x13 A304	2					
11	H352817000	ZOCALO BAÑO MARIA	BAIN MARIE SKIRTING	1					
	Q419005000	REMACHE 4x8 ALMG3 / ALUMINIO	RIVET 4X8 ALMG3 / ALUMINIUM	2					
12	U022629000	BASE 1 M GAS	BASE 1 M GAS	1					
	Q419005000	REMACHE 4x8 ALMG3 / ALUMINIO	RIVET 4X8 ALMG3 / ALUMINIUM	9					
13	H012805000	ESCUADRA AMARRE PATA	LEG FASTENING BRACKET	2					
	Q162030000	TUERCA EXAGONAL M5	HEXAGONAL NUT M5	4					
	Q302022000	ARANDELA 16x6x1,2 A304	WASHER 16x6x1.2 A304	4					
	Q221345000	REMACHE EXAGONAL M10	HEXAGONAL RIVET M10	2					
14	R062811000	PANEL LATERAL IZQUIERDO G900	LEFT SIDE PANEL G900	1					
	Q221342000	REMACHE EXAGONAL M5	HEXAGONAL RIVET M5	3					
	Q221343000	REMACHE EXAGONAL M6	HEXAGONAL RIVET M6	5					



Зип Общепит

ysezip.ru

+7(812)987-08-81

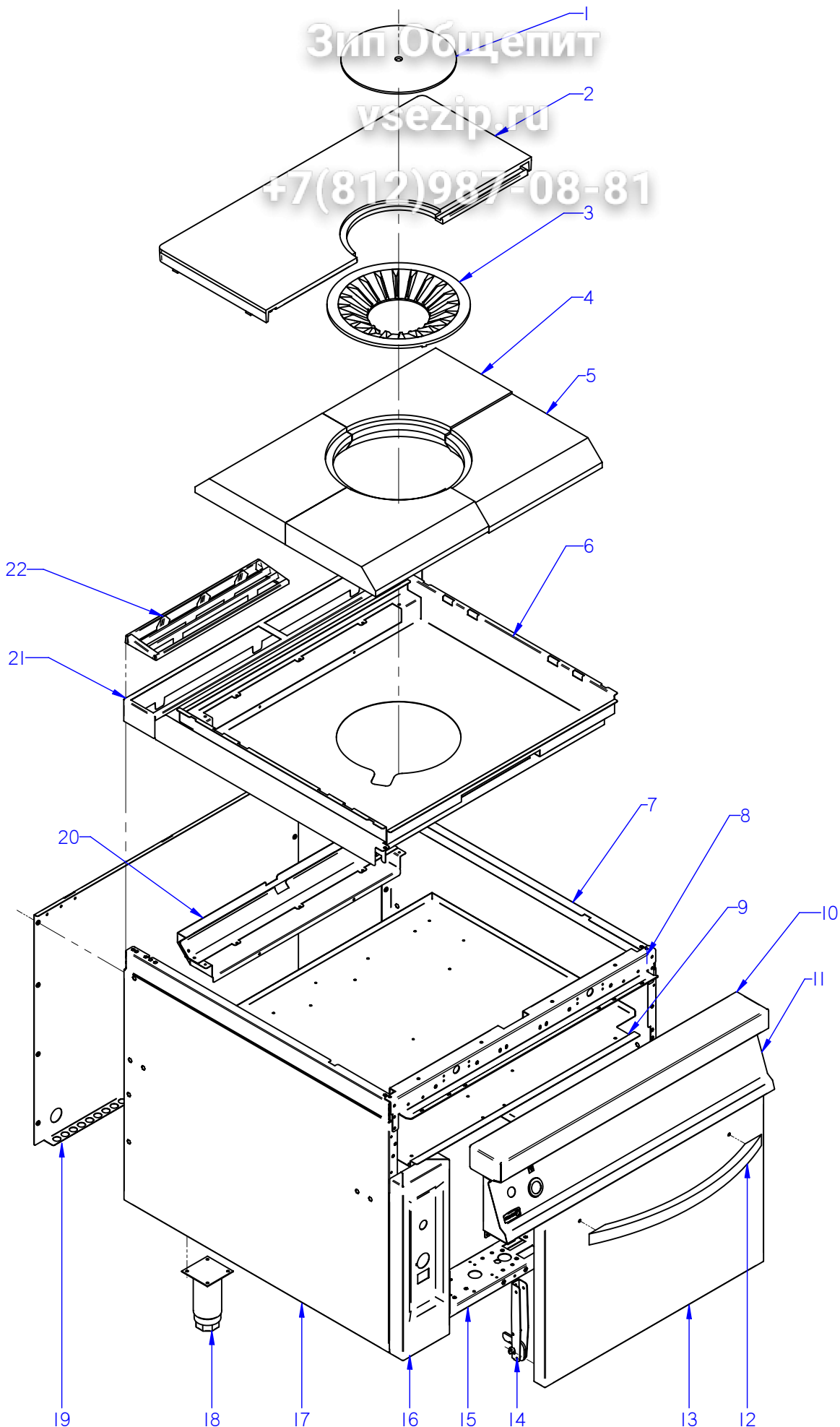

ITEM MARCADO EN COLOR = REPUESTO RECOMENDADO  
COLOURED ITEM = RECOMMENDED SPARE PART

N plano	Firma	Fecha	Aparato	MUEBLE	Lamina	Fagor Industrial S.Coop. <b>FAGOR</b>
C-2351	<i>[Signature]</i>	2009-06	COCINA CG9-11 / CGE9-11		2	Oñate

MOD.		COCINAS		ZONA		MUEBLE / UNIT			
ITEM	CODIGO	DENOMINACION	TEXTO	CG9-11	CGE9-11				
1	U195421000	RODELA	GUIDE RING	1	1				
2	U025412000	MEDIA PLACA G900	MEDIUM PLATE G900	2	2				
3	U195420000	RODELA DIFUSORA FG-8	DISPENSER GUIDE RING FG-8	1	1				
4	U615408000	REFRACTARIO DERECHO	RIGHT REFRACTORY	2	2				
5	U615407000	REFRACTARIO IZQUIERDO	LEFT REFRACTORY	2	2				
6	U615464000	CAJON REFRACTARIO	REFRACTORY DRAWER	1	1				
7	U022842000	PANEL LATERAL DERECHO G9-00	RIGHT SIDE PANEL G9-00	1	1				
	Q221343000	REMACHE EXAGONAL M6	HEXAGONAL RIVET M6	11	11				
	Q221342000	REMACHE EXAGONAL M5	HEXAGONAL RIVET M5	11	11				
	Q012043000	TORNILLO EXAGONAL M6x20 A304	HEXAGONAL BOLT M6x20 A304	2	2				
	Q152004000	TORNILLO APLASTADO M5x13 A304	FLAT HEADED BOLT M5x13 A304	3	3				
8	U022632000	ESCUA INTER AMAR ANTE 1 M	BRACKET INTER FASTE. FRONT	1	1				
	Q221342000	REMACHE EXAGONAL M5	HEXAGONAL RIVET M5	4	4				
	Q012032000	TORNILLO EXAGONAL M5x15	HEXAGONAL BOLT M5x15	4	4				
	Q152004000	TORNIL, APLASTADO M5x13 A304	FLAT HEADED BOLT M5x13 A304	6	6				
	Q302022000	ARANDELA 16x6x1,2 A304	WASHER 16x6x1.2 A304	6	6				
9	U022613000	BASE BANDEJAS 1 M	TRAY BASE 1 M	1	1				
	Q419005000	REMACHE 4x8 ALMG3 / ALUMINIO	RIVET 4X8 ALMG3 / ALUMINIUM	2	2				
	Q152004000	TORNIL, APLASTADO M5x13 A304	FLAT HEADED BOLT M5x13 A304	3	3				
10	S105402000	ANTERIOR MESA 1 M	BENCH FRONT 1 M	1	1				
	Q152004000	TORNIL, APLASTADO M5x13 A304	FLAT HEADED BOLT M5x13 A304	2	2				
	Q302022000	ARANDELA 16x6x1,2 A304	WASHER 16x6x1.2 A304	2	2				
11	U022855000	PORTAMANDOS COMPL. CG9-11	CONTROL HOLDER CG9-11	1	1				
	U022836000	ESCUDO FAGOR	FAGOR EMBLEM	1	1				
	Q221023000	CLIP SUJECIÓN RÁPIDA Ø5	RAPID CONNECT CLIP Ø5	2	2				
	Q152004000	TORNIL, APLASTADO M5x13 A304	FLAT HEADED BOLT M5x13 A304	4	4				
12	U020504000	ASA DE HORNO COMPLETA G900	COMPL. OVEN HANDLE G900	1	1				
	Q012041000	TORNILLO EXAGONAL M6x10	HEXAGONAL BOLT M6x10	2	2				
	Q302022000	ARANDELA 16x6x1,2 A304	WASHER 16x6x1.2 A304	2	2				
	<b>12038310</b>	<b>KIT PUERTA HORNO</b>	<b>OVEN DOOR KIT</b>	<b>1</b>	<b>1</b>				
13	U910501000	PUERTA DE HORNO	OVEN DOOR	1	1				

MOD.	COCINAS	ZONA	MUEBLE / UNIT					
ITEM	CODIGO	DENOMINACION	TEXTO	CG9-11	CGE9-11			
14	U020528000	BISAGRA CIERRE HORNO	OVEN LOCK HINGE	2	2			
	Q152022000	TORNILLO M6x8	BOLT M6x8	6	6			
15	U022625000	LISTON SOPORTE PATAS 1 M	LEG SUPPORT STRIP 1 M	2	2			
16	U022843000	PORTAMANDOS LATERAL HORNO	OVEN SIDE CONTROL HOLDER	1	-			
16	U962829000	PORTAMAND. LATERAL HORNO AD	OVEN SIDE CONTROL HOLD. AD	1	-			
16	U672855000	PORTAMANDOS LATERAL HORNO	OVEN SIDE CONTROL HOLDER	-	1			
16	12041036	PORTAM. LATERAL HORNO ELECT.	OVEN SIDE CONTROL HOLDER	-	1			
	Q152004000	TORNIL, APLASTADO M5x13 A304	FLAT HEADED BOLT M5x13 A304	2	2			
17	X162813000	PANEL LATERAL IZQUIERDO G900	LEFT SIDE PANEL G900	1	1			
	Q221343000	REMACHE EXAGONAL M6	HEXAGONAL RIVET M6	11	11			
	Q221342000	REMACHE EXAGONAL M5	HEXAGONAL RIVET M5	11	11			
	Q012043000	TORNILLO EXAGONAL M6x20 A304	HEXAGONAL BOLT M6x20 A304	2	2			
	Q152004000	TORNILLO APLASTADO M5x13 A304	FLAT HEADED BOLT M5x13 A304	3	3			
18	X260151000	PATA REGULABLE	ADJUSTABLE LEG	4	4			
	Q411304000	REMACHE AVIBULB Ø 4,8	AVIBULB RIVET Ø 4.8	16	16			
19	U562853000	PANEL POSTERIOR 1 M	REAR PANEL 1 M	1	1			
	Q419005000	REMACHE 4x8 ALMG3 / ALUMINIO	RIVET 4X8 ALMG3 / ALUMINIUM	8	8			
20	U615467000	ANTERIOR DE CHIMENEA	FLUEPIPE FRONT	1	1			
S/Nº	U615466000	POSTERIOR CHIMENEA	REAR FLUEPIPE	1	1			
	Q419005000	REMACHE 4x8 ALMG3 / ALUMINIO	RIVET 4X8 ALMG3 / ALUMINIUM	11	11			
21	R205439000	SOPORTE EMBELLECEDOR 1 M	TRIM SUPPORT 1 M	1	1			
22	R205425000	EMBELLECEDOR ESMALTE	ENAMEL TRIM	2	2			

Зип Общепит

vsezip.ru

+7(812)987-08-81

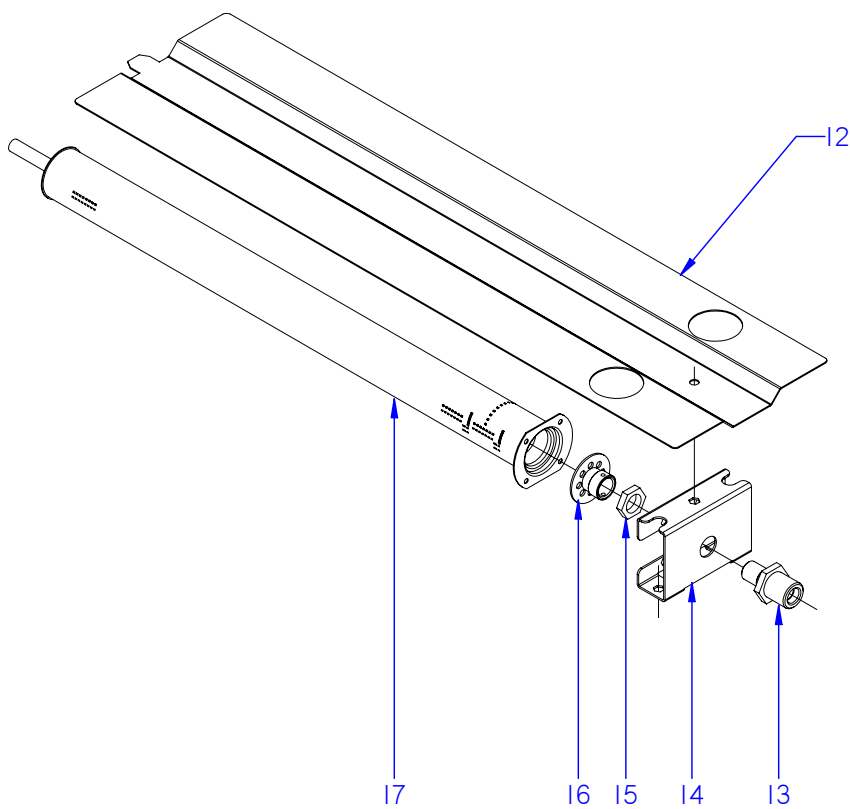
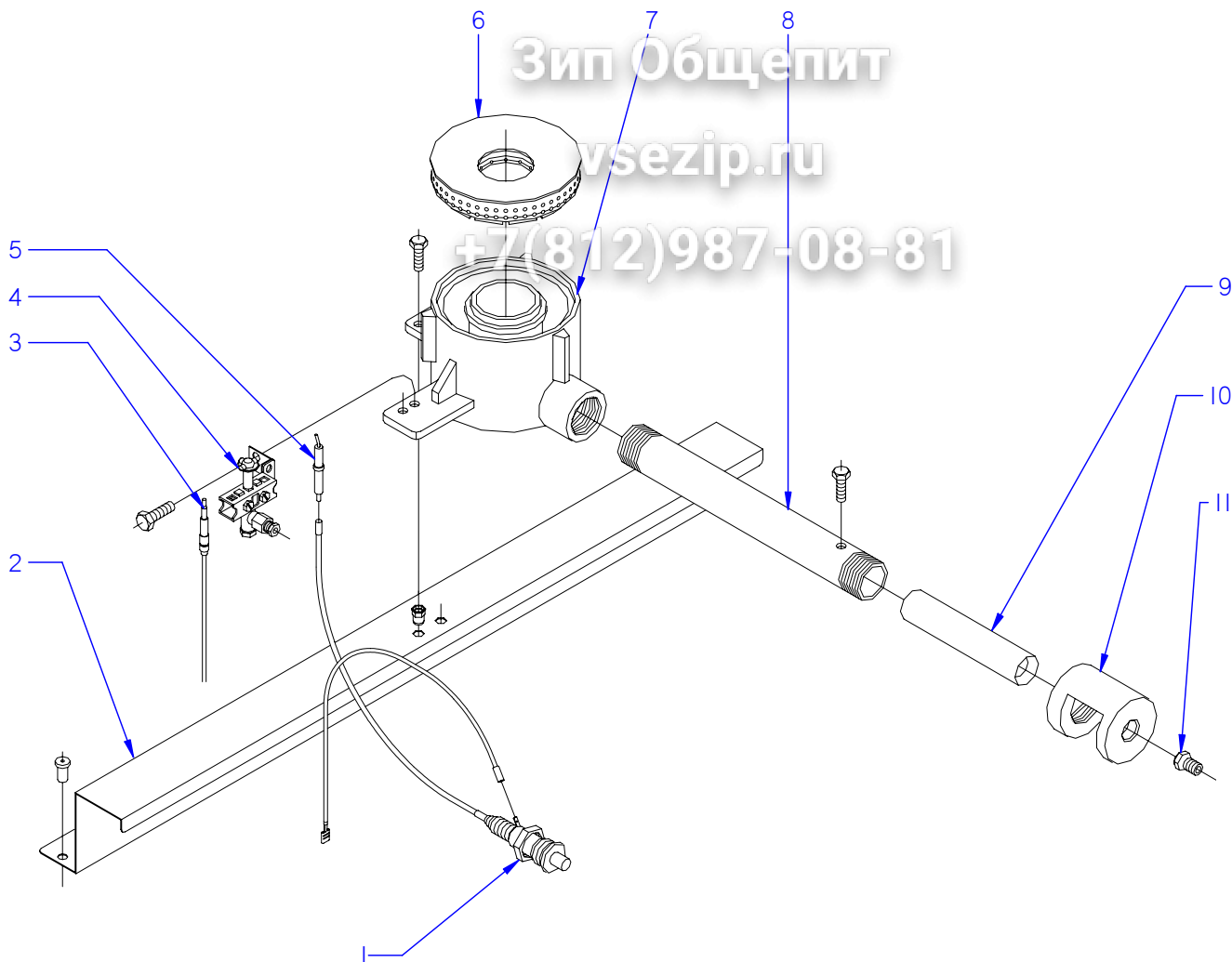

ITEM MARCADO EN COLOR = REPUESTO RECOMENDADO  
COLOURED ITEM = RECOMMENDED SPARE PART

N plano	Firma	Fecha	Aparato	QUEMADORES	Lamina	Fagor Industrial S.Coop. <b>FAGOR</b>
C-2352	<i>(Signature)</i>	2009-06	COCINAS CG9-10 / CG9-11 / CG9-11		3	Oñate



MOD.		COCINAS		ZONA		QUEMADORES / BURNERS		
ITEM	CODIGO	DENOMINACION	TEXTO	CG9-10	CG9-11	CGE9-11		
1	S113034000	PIEZOELECTRICO	PIEZOELECTRIC	1	2	1		
1	12043897	PIEZOELECTRICO COMPLETO	COMPLETE PIEZOELECTRIC	1	2	1		
S/Nº	12043907	ANILLO ADAPTADOR	ADAPTER RING	1	1	1		
S/Nº	U333003000	CABLE MASA ENCENDEADOR	LIGHTER EARTH CABLE	1	1	1		
2	U612653000	SOPORTE QUEMADOR DE MESA	BURNER SUPPORT STRIP	1	1	1		
	Q419005000	REMACHE 4x8 ALMG3 / ALUMINIO	RIVET 4X8 ALMG3 / ALUMINIUM	2	2	2		
	Q221342000	REMACHE EXAGONAL M5	HEXAGONAL RIVET M5	2	2	2		
3	U222130000	TERMOPAR L=600	THERMOCOUPLE L=600	1	1	1		
4	U192104000	PILOTO COMPLETO	COMPLETE PILOT LIGHT	1	1	1		
S/Nº	U442131000	AMARRE DEL. PILOTO 978.021	PILOT FASTENING 978.021	1	1	1		
S/Nº	U442137000	INYECTOR Ø 0,4 GN	INJECTOR Ø 0.4 GN.	1	1	1		
5	X022131000	BUJIA	SPARK PLUG	1	1	1		
S/Nº	U323030000	CABLE BUJIA	SPARK PLUG CABLE	1	1	1		
6	U195701500	QUEMADOR 10850 KCAL. PINTADO	BURNER10850 KCAL.	1	1	1		
6	12091667	QUEMADOR 11,5 Kw PINTADO	BURNER 11,5 Kw PAINTED	1	1	1		
7	U195702000	CUERPO DE QUEMADOR MECANI.	BURNER BODY	1	1	1		
8	U195703000	TUBO MEZCLADOR	MIXING PIPE	1	1	1		
	Q223019000	TUERCA 3/8 GAS LATÓN	NUT 3/8 GAS BRASS	1	1	1		
	Q153002000	TORNILLO TAPON	CAP BOLT	1	1	1		
9	U775701000	VENTURI QUEMADOR	VENTURI QUEMADOR	1	1	1		
	Q012031000	TORNILLO EXAGONAL M5x10 A304	HEXAGONAL BOLT M5x10 A304	1	1	1		
10	U615700500	CAMARA DE MEZCLA PINTADA	PAINT MIXING CHAMBER	1	1	1		
11	R302400000	TOBERA Ø 1,65 BP	NOZZLE Ø 1,65 BP	1	1	1		
11	U054400000	TOBERA Ø 2,50 GN	NOZZLE Ø 2,50 GN	1	1	1		
12	U915613000	DEFLECTOR QUEMADOR HORNO	OVEN BURNER DEFLECTOR	—	2	—		
	Q152004000	TORNIL, APLASTADO M5x13 A304	FLAT HEADED BOLT M5x13 A304	—	1	—		
	Q302022000	ARANDELA 16x6x1,2 A304	WASHER 16x6x1.2 A304	—	1	—		
13	X505724000	MANGUITO PORTATOBERAS	NOZZLE HOLDER SLEEVE	—	1	—		
14	U105635000	AMARRE QUEMADOR HORNO(HG)	OVEN BURNER FASTENING (HG)	—	1	—		
	Q012031000	TORNILLO EXAGONAL M5x10 A304	HEXAGONAL BOLT M5x10 A304	—	2	—		
	Q222041000	REMACHE EXAGONAL M4 (INOX)	HEXAGONAL RIVET M4 (INOX)	—	4	—		



Зип Общепит

vsezip.ru

+7(812)987-08-81

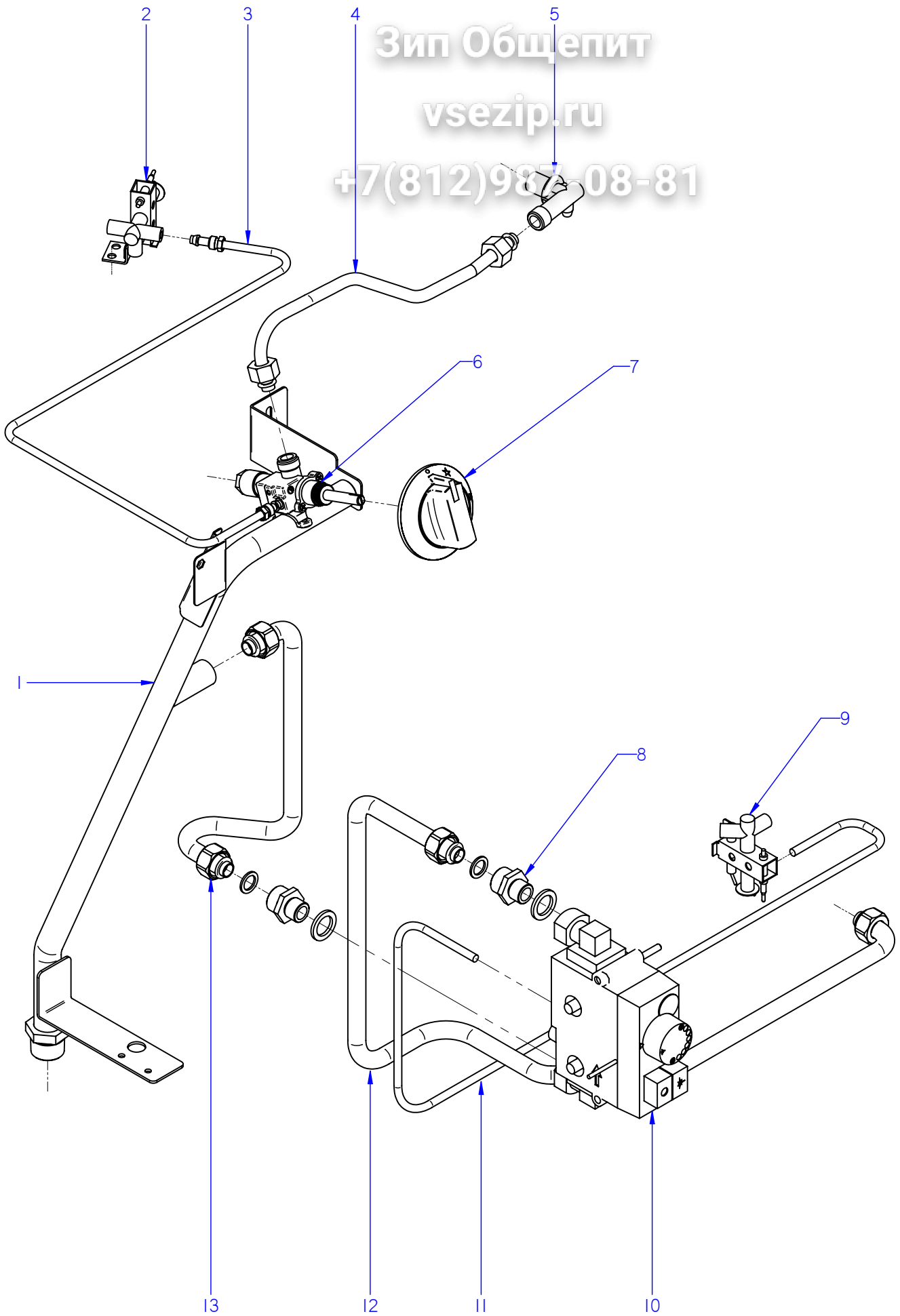

ITEM MARCADO EN COLOR = REPUESTO RECOMENDADO  
COLOURED ITEM = RECOMMENDED SPARE PART

N plano	Firma	Fecha	Aparato	CONDUCCIONES Y GRIFOS	Lamina	Fagor Industrial S.Coop. <b>FAGOR</b>
C-2353	<i>(Signature)</i>	2009-06	COCINAS CG9-10 / CG9-11 / CG9-11		4	Oñate

MOD.	COCINAS	ZONA	CONDUCCIONES Y GRIFOS / PIPES AND T					
ITEM	CODIGO	DENOMINACION	TEXTO	CG9-10	CG9-11	CGE9-11		
1	U645055000	DISTRIBUIDOR COMPLET. CG9-10	COMPL. DISTRIBUTOR CG9-10	1	_	_		
1	U615058000	DISTRIBUIDOR COMPLET. CG9-11	COMPL. DISTRIBUTOR CG9-11	_	1	_		
1	U615062000	DISTRIBUIDOR COMPLET. CGE9-11	COMPL. DISTRIBUTOR CGE9-11	_	_	1		
	Q221342000	REMACHE EXAGONAL M5	HEXAGONAL RIVET M5	1	1	1		
	Q152004000	TORNIL, APLASTADO M5x13 A304	FLAT HEADED BOLT M5x13 A304	2	1	2		
	U635008000	TUERCA CIEGA 3/4	BLIND NUT 3/4	2	_	_		
	Q306051000	ARANDELA TAPON Ø23,5x3	LID WASHER Ø23.5x3	2	_	_		
2	U192104000	PILOTO COMPLETO	COMPLETE PILOT LIGHT	1	1	1		
3	U615060000	TUBO PILOTO	PILOT PIPE	1	1	1		
	X205028000	BICONO Ø 6	BICONE Ø 6	1	1	1		
	U195009000	MANGUITO EMPALME	CONNECTION HOSE	1	1	1		
4	U205034000	TUBO VALVULA QUEMADOR	BURNER VALVE PIPE	1	1	1		
5	U915014000	PORTATOVERAS HORNO	OVEN NOZZLE HOLDER	1	1	1		
6	U942102000	GRIFO 18700 BY-PASS 1,20	TAP 18700 BY-PASS 1,20	1	1	1		
S/Nº	U912104000	BRIDA AMARRE GRIFO 1/2"	TAP FASTENING FLANGE 1/2"	1	1	1		
	Q122032000	TORNILLO ALLEN M5x15	ALLEN BOLT M5x15	1	1	1		
7	U022117000	MANDO MONT COCINA GAS Ø8	GAS COOK. ASSEMBLY CTRL Ø8	1	1	1		
8	U202103000	MANGUITO REDUCCION 1/2-3/8"	REDUCTION HOSE 1/2-3/8"	_	2	_		
	Q306058000	ARANDELA 25x17X2.5	WASHER 25x17X2.5	_	2	_		
9	U322118000	PILOTO COMPLETO 100.062	COMPLETE PILOT LIGHT 100,062	_	1	_		
S/Nº	U442137000	INYECTOR Ø 0,4 GN	INJECTOR Ø 0.4 GN.	_	1	_		
S/Nº	U562130000	TERMOPAR L=850	THERMOCOUPLE L=850	_	1	_		
	Q012031000	TORNILLO EXAGONAL M5x15 A304	HEXAGONAL BOLT M5x15 A304	_	2	_		
10	U134324000	VALVULA MINISIT 0710.654	VALVE MINISIT 0710.654	_	1	_		
S/Nº	Q307041000	JUNTA TORICA 25,4x20,2x2,6	O-RING 25.4x20.2x2.6	_	2	_		
S/Nº	U134317000	MANDO NEGRO MINI 916.124	BLACK CTRL. MINI 916.124	_	1	_		
S/Nº	U134318000	CUBIERTA MINISIT 903.052	COVER MINISIT 903.052	_	1	_		
S/Nº	Q031322000	TORNILLO ALOMADO M4x15	CURVED SCREW M4X15	_	8	_		
S/Nº	U264300000	RACOR 3/8 906,252	CONNECTION 3/8 906.252	_	2	_		
S/Nº	U134323000	RACORD BICONO 6 958.031	BICONE CONNECTION 6 958.031	_	1	_		



Зип Общепит

vsezip.ru

+7(812)987-08-81

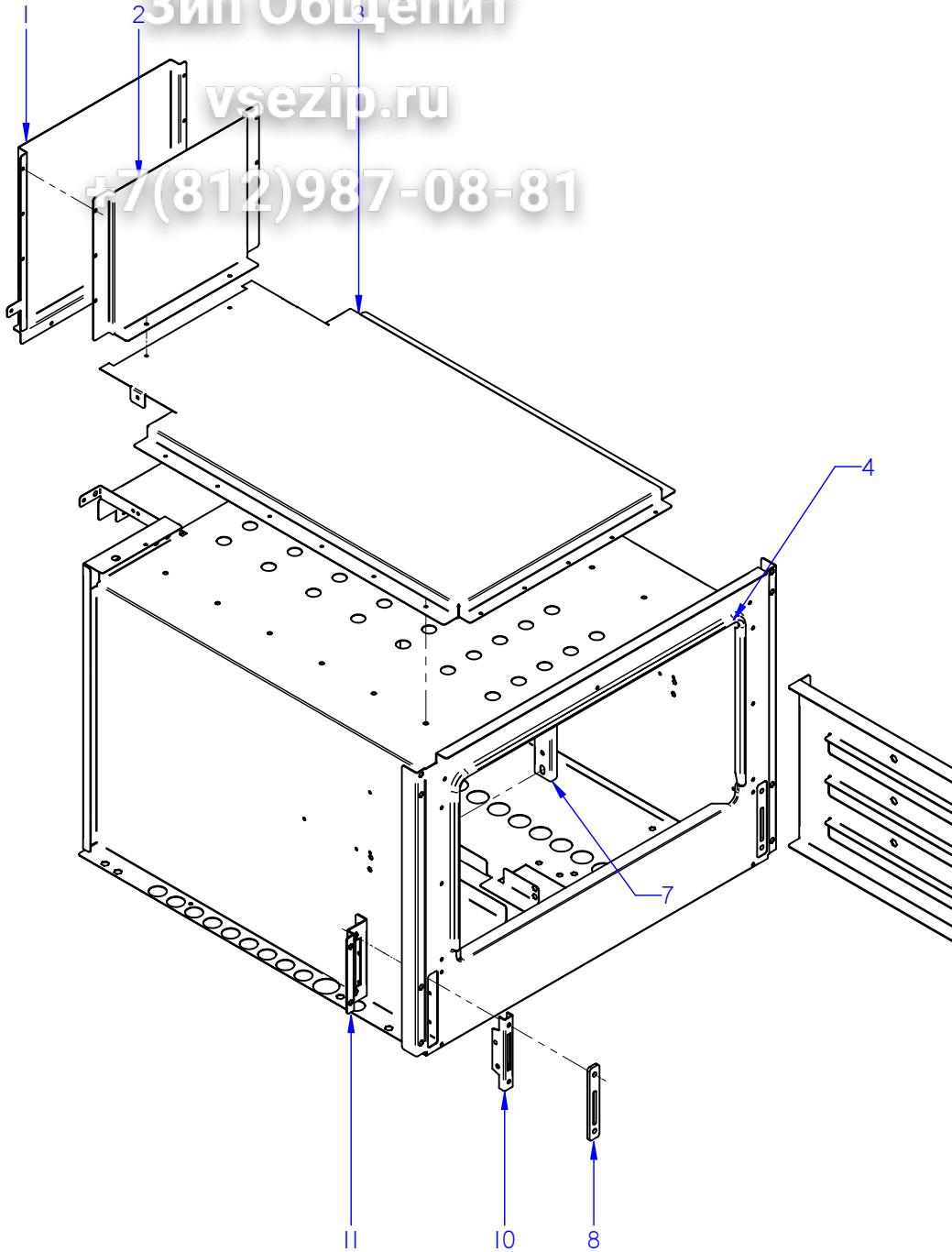

ITEM MARCADO EN COLOR = REPUESTO RECOMENDADO  
COLOURED ITEM = RECOMMENDED SPARE PART

N plano	Firma	Fecha	Aparato	Lamina	Fagor Industrial S. Coop. <b>FAGOR</b> Ortze
C-2354	<i>(Signature)</i>	2009-06	COCINA CG9-11	5	

HORNO



Зип Общепит

vsezip.ru

+7(812)987-08-81

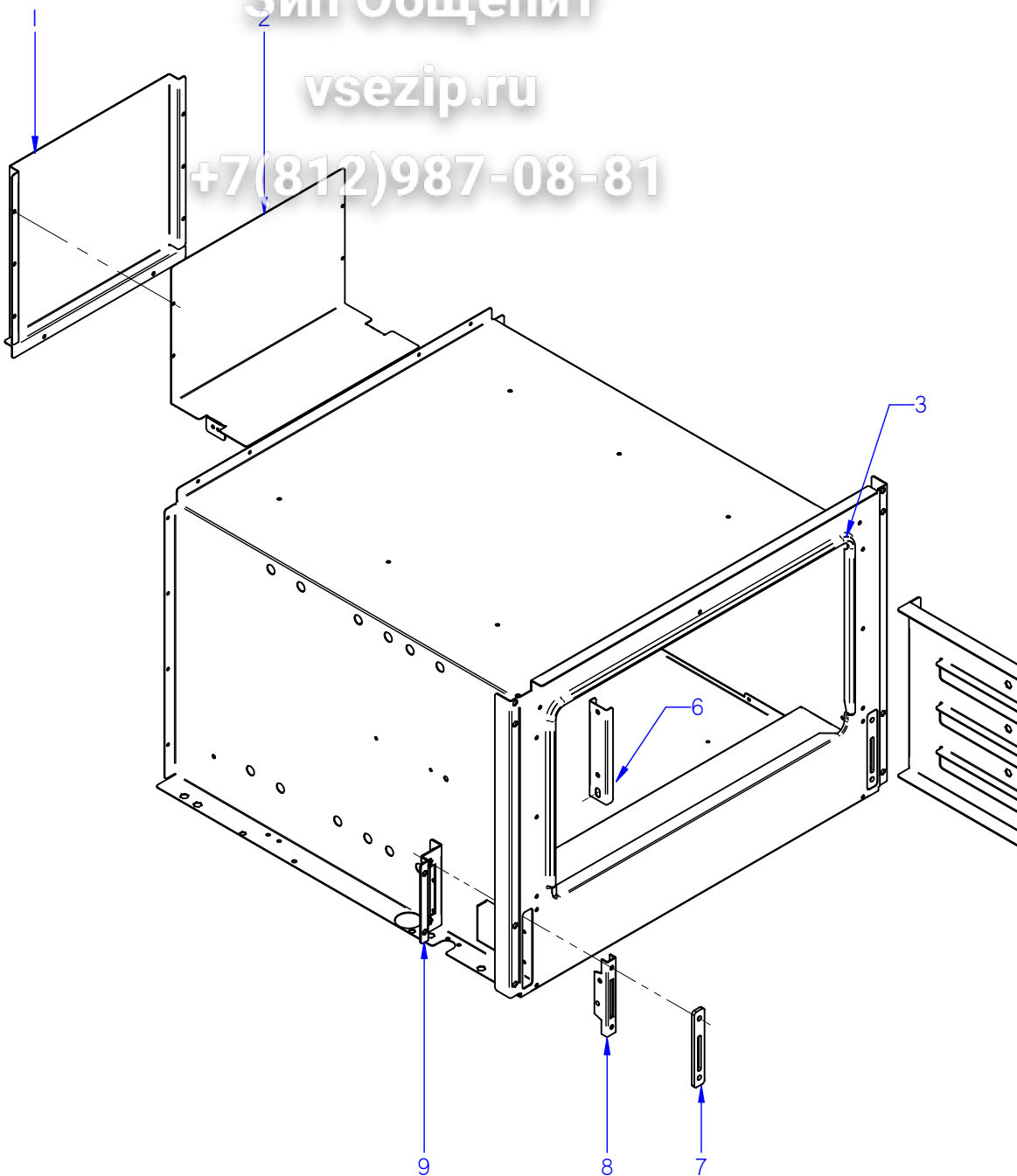

ITEM MARCADO EN COLOR = REPUESTO RECOMENDADO  
COLOURED ITEM = RECOMMENDED SPARE PART

N plano	Firma	Fecha	Aparato	HORNO	Lamina	Fagor Industrial S. Coop. <b>FAGOR</b> Onofre
C-23355	<i>(Signature)</i>	2009-06	COCINA CGE9-11		6	





Зип Общепит

vsezip.ru

+7(812)987-08-81

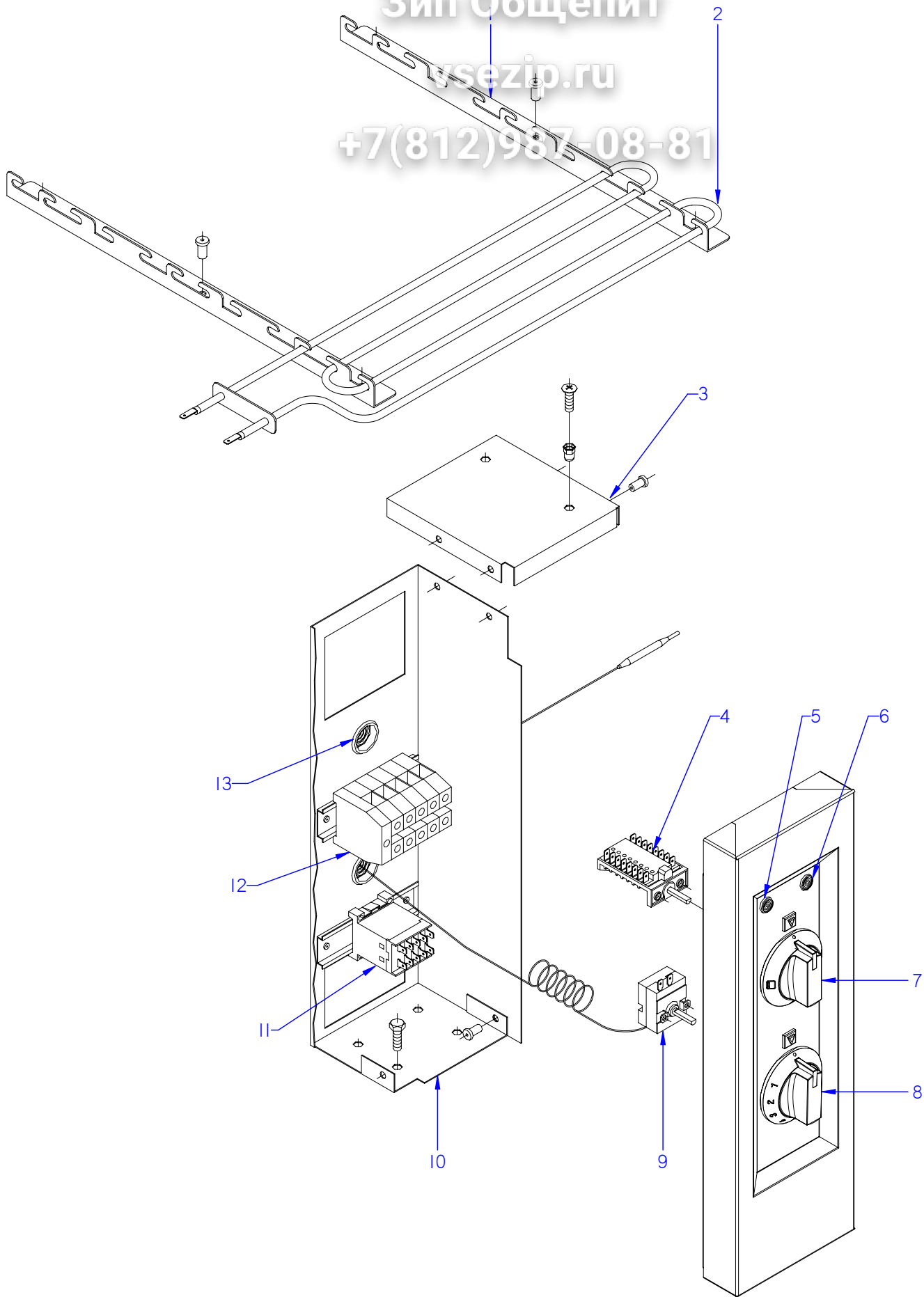

ITEM MARCADO EN COLOR = REPUESTO RECOMENDADO  
COLOURED ITEM = RECOMMENDED SPARE PART

N plano	Firma	Fecha	Aparato	CONJUNTO FUNCIONAL ELECTRICO	Lamina	Fagor Industrial S.Coop. <b>FAGOR</b>
C-2356	<i>[Signature]</i>	2009-06	COCINA CGE9-11		7	Oñate

MOD.		COCINAS		ZONA		CONJUNTO FUNCIONAL ELECTRICO			
ITEM	CODIGO	DENOMINACION	TEXTO	CGE9-11					
1	U805613000	ESCUADRA SOPOR. RESISTENCIAS	SUPP. BRACKET RESISTORS	4					
	Q419005000	REMACHE 4x8 ALMG3 / ALUMINIO	RIVET 4X8 ALMG3 / ALUMINIUM	12					
2	U803004000	RESISTENCIA 1000W/230V	RESISTOR 1000W -230V	6					
3	U673051000	TAPA DE CUADRO ELECTRICO	ELECTRIC PANEL COVER	1					
	Q419005000	REMACHE 4x8 ALMG3 / ALUMINIO	RIVET 4X8 ALMG3 / ALUMINIUM	4					
	Q419005000	REMACHE 4x8 ALMG3 / ALUMINIO	RIVET 4X8 ALMG3 / ALUMINIUM	2					
	Q221342000	REMACHE EXAGONAL M5	HEXAGONAL RIVET M5	2					
	Q012032000	TORNILLO EXAGONAL M5x15 A304	HEXAGONAL BOLT M5x15	2					
	Q012032000	TORNILLO EXAGONAL M5x15 A304	HEXAGONAL BOLT M5x15	2					
4	U673006000	CONMUTADOR	SWITCH	1					
	Q151320000	TORNILLO ALOMADO M4x6 H.ZINC.	CURVED SCREW M4X6 H. ZINC	2					
5	R693055000	PILOTO VERDE 41227000C7	GREEN PILOT 41227000C7	1					
5	12047390	PILOTO VERDE 230V AC 8KW 16MM	GREEN PILOT 230V AC 8KW 16M	1					
6	R693056000	PILOTO AMBAR 41227000A4	AMBER PILOT 41227000A4	1					
6	12024669	PILOTO AMBAR Ø18	AMBER PILOT Ø18	1					
7	U173006000	MANDO MONTADO CE Ø6	CONTROL CE Ø6	1					
8	U173005000	MANDO CE Ø6 TERMOSTATO	CONTROL Ø6 THERMOSTAT	1					
9	X153000000	TERMOSTATO 50-310° C	THERMOSTAT 50-310 C	1					
	Q151320000	TORNILLO ALOMADO M4x6 H.ZINC.	CURVED SCREW M4X6 H. ZINC	2					
10	U673050000	CUADRO ELECTRICO	ELECTRICAL PANEL	1					
11	Z213007000	CONTACTOR 3TF2010-3AL2	CONTACTOR 3TF2010-3AL2	1					
	R663055000	GUIA CONTACTOR L-120	CONTACTOR GUIDE L-120	1					
	Q419005000	REMACHE 4x8 ALMG3 / ALUMINIO	RIVET 4X8 ALMG3 / ALUMINIUM	4					
12	P453025000	BORNES 10 WDU-10203.0	TERMINALS 10 WDU-10203.0	3					
	Z263302000	BORNA NEUTRO AZUL 57A 10mm	BLUE NEUTRAL TERMINAL 57A	1					
	U803009000	BORNA PASO AZUL 16 MM.	BLUE TAP TERMINAL 16MM	1					
	P453026000	BORNA TIERRA 10 WPE-10103.0	TERMINAL TIER 10 WPE-10103.0	1					
	Z263303000	TOPE FINAL	END STOP	1					
	R663055000	GUIA CONTACTOR L-120	CONTACTOR GUIDE L-120	1					
13	X723014000	PASAMUROS AMETRO 30		2					



MOD.		FREIDORAS		ZONA		REPUESTOS RECOMENDADOS RECOMMENDED SPARE PART			
ITEM	CODIGO	DENOMINACION	TEXTO	CG9-10	CG9-11	CGE9-11			
14	U020528000	BISAGRA CIERRE HORNO	OVEN LOCK HINGE	—	2	2			
3	U222130000	TERMOPAR L=600	THERMOCOUPLE L=600	1	1	1			
4	U192104000	PILOTO COMPLETO	COMPLETE PILOT LIGHT	1	1	1			
S/Nº	U442131000	AMARRE DEL. PILOTO 978.021	PILOT FASTENING 978.021	1	1	1			
S/Nº	U442137000	INYECTOR Ø 0,4 GN	INJECTOR Ø 0.4 GN.	1	1	1			
5	X022131000	BUJIA	SPARK PLUG	1	1	1			
12	U915613000	DEFLECTOR QUEMADOR HORNO	OVEN BURNER DEFLECTOR	—	2	—			
2	U192104000	PILOTO COMPLETO	COMPLETE PILOT LIGHT	1	1	—			
6	U942102000	GRIFO 18700 BY-PASS 1,20	TAP 18700 BY-PASS 1,20	1	1	—			
9	U322118000	PILOTO COMPLETO 100.062	COMPLETE PILOT LIGHT 100,062	—	1	—			
S/Nº	U442137000	INYECTOR Ø 0,4 GN	INJECTOR Ø 0.4 GN.	—	1	—			
S/Nº	U562130000	TERMOPAR L=850	THERMOCOUPLE L=850	—	1	—			
10	U134324000	VALVULA MINISIT 0710.654	VALVE MINISIT 0710.654	—	1	—			
4	U965613000	JUNTA HORNO FIBRA DE VIDRIO	FURNACE FIBERGLASS BOARD	—	1	—			
10	12041846	GUIA BISAGRA G700 Y G900	HINGE GUIDE G700 Y G900	—	2	—			
3	U965613000	JUNTA HORNO FIBRA DE VIDRIO	FURNACE FIBERGLASS BOARD	—	—	1			
8	12041846	GUIA BISAGRA G700 Y G900	HINGE GUIDE G700 Y G900	—	—	2			
2	U803004000	RESISTENCIA 1000W/230V	RESISTOR 1000W -230V	—	—	6			
4	U673006000	CONMUTADOR	SWITCH	—	—	1			
5	12047390	PILOTO VERDE 230V AC 8KW 16MM	GREEN PILOT 230V AC 8KW 16M	—	—	1			
6	12024669	PILOTO AMBAR Ø18	AMBER PILOT Ø18	—	—	1			
9	X153000000	TERMOSTATO 50-310º C	THERMOSTAT 50-310 C	—	—	1			

# Зип Общепит

vsezi.ru

+7(812)987-08-81

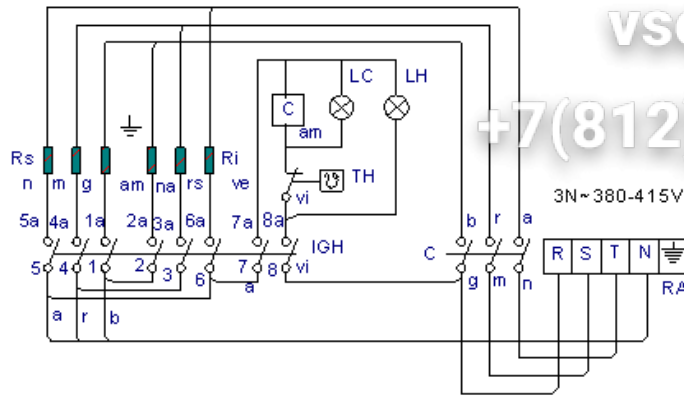

- RA: Regleta de Alimentacion
- IGH: Conmutador General Horno
- C: Contactor
- LC: Lampara Calentamiento Horno
- LH: Lampara Horno Encendido
- TH: Termostato de Horno
- Rs: Resistencia Homo Superior
- Ri: Resistencia Horno Inferior

- r = rojo-red-rouge
- m = marron-brown-marron
- g = gris-grey-gris
- n = negro-black-noir
- a = azul-blue-bleu
- b = blanco-white-blanc
- vi = violeta-violette-violet
- am = amarillo-yellowjaune
- na = naranja-orange-orang
- rs = rosa-rose-pink
- ve = verde-green-vert
- am/ve = amarillo/verde-yell

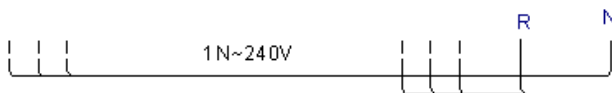
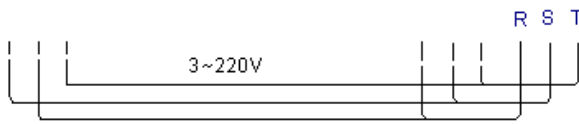
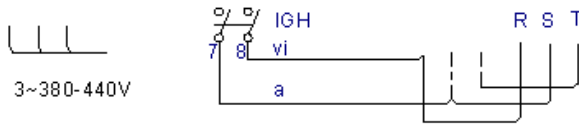

	1_2	3_4	5_6	7	8
	1a	2a	3a	4a	5a
0					
1	X		X	X	X
2	X	X	X	X	X
3		X	X		X

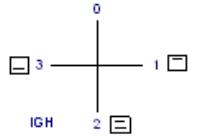

Esquema teorico adhesivo		
Nº	Pieza	
Nº	Modificacion	
Dibujado		Fecha
Proyectado		01-11-200
Comprobado		
Escala		
1/1		
Firma		
M. J. Malib		
Fecha		
01-11-200		