

Зип Общепит

vsezip.ru

DESPIECE TECNICO

+7(812)987-08-81

**Cocinas centrales
Gas central ranges
Fourneaux traversants
Zentral-herde
Cucine centrale
Fogões centrais**

GAMA 1000

Modelos:

CG-1002

Julio 2010 July

Revisado Julio 2013 July Revised

FAGOR 

F A G O R I N D U S T R I A L

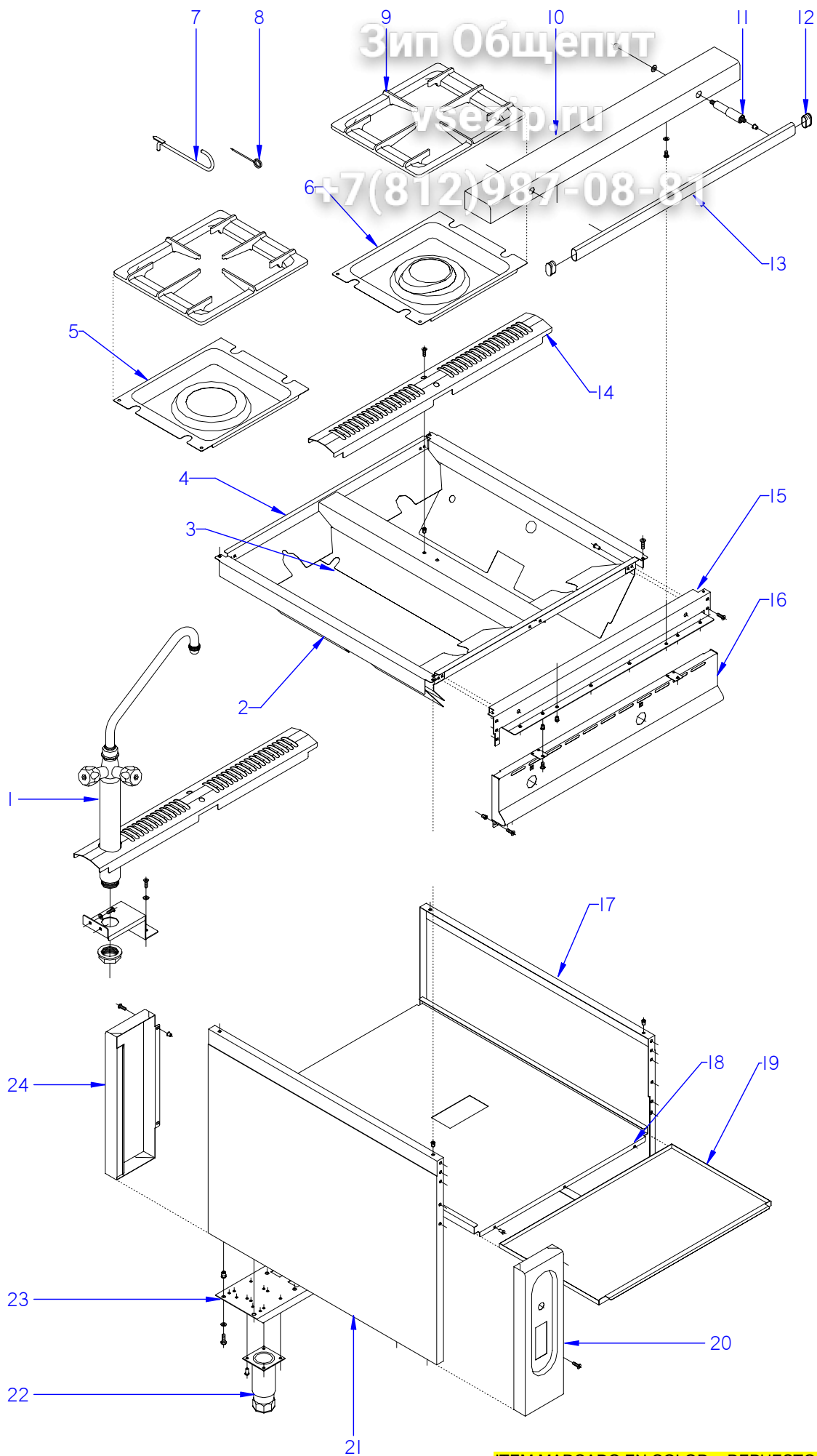

ITEM MARCADO EN COLOR = REPUESTO RECOMENDADO
 COLOURED ITEM = RECOMMENDED SPARE PART

N plano	Firma	Fecha	Aparato	MUEBLE / FITTING	Lamina	Fagor Industrial S.Coop. FAGOR
C-2688	<i>(Signature)</i>	2010-07	COCINAS / RANGES CG-1002		1	Oñate

MOD.		COCINAS / RANGES	ZONA / ZONE	MUEBLE / FITTING			
ITEM	CODIGO CODE	DENOMINACION	NAME	CG-1002			
1	1100002785	KIT GRIFO DE AGUA	TAP WATER KIT	1			
2	U865404000	LATERAL DE MESA	SIDE TABLE	2			
	Q152004000	TORNIL, APLASTADO M5x13 A304	FLAT HEADED BOLT M5x13 A304	4			
	Q221342000	REMACHE EXAGONAL M5	HEXAGONAL RIVET M5	4			
3	U865406000	CENTRAL MESA	CENTRAL TABLE	1			
	Q221342000	REMACHE EXAGONAL M5	HEXAGONAL RIVET M5	2			
4	U865405000	INTERIOR DE MESA	BENCH SIDE	2			
	Q412000000	REMACHE TUBULAR Ø4 x 8	TUBULAR RIVET Ø4 x 8	6			
5	U025405000	VERTEDERO 8000	DISCHARGE 8000	2			
6	U025404000	VERTEDERO 4000	DISCHARGE 4000	2			
7	623600000	PALANCA LEVANTAPLACAS	LIFTING LEVER PLATES	1			
8	623500000	AGUJA LIMPIEZA	NEEDLE CLEANING	1			
9	U035409000	PARRILLA G900	GRILLE G900	4			
10	U865407000	ANTERIOR MESA	BENCH FRONT	2			
	Q152004000	TORNIL, APLASTADO M5x13 A304	FLAT HEADED BOLT M5x13 A304	4			
11	U705410000	AMARRE DISTANCIADOR PASAM.	TIE RAIL SPACER	4			
	Q161360000	TUERCA EXAGONAL M10 H.ZINCA.	H. ZINC M10 HEX NUT	4			
	Q232060000	ARANDELA A10	WASHER A10	4			
12	U702831000	TAPON DE PASAMANOS	CAP HANDRAILS	4			
	Q411308000	REMACHE TUBTARA M10	TUBTARA RIVET M10	4			
13	U862803000	PASAMANOS	HANDRAILS	2			
14	U865400000	EMBELLECEDOR CHIMENEA	FLUE TRIM	1			
14	U865400000S	EMBELLECEDOR CHIMENEA ESM.	GLAZED FLUE TRIM	1			
	Q032035000	TORNILLO ALOMADO M5X30	ALOHA SCREW M5X30	2			
15	R162613000	ESCUADRA AMARRE ANTER. MESA	PREVIOUS TIE SQUARE TABLE	2			
	Q152004000	TORNIL, APLASTADO M5x13 A304	FLAT HEADED BOLT M5x13 A304	12			
16	U862800000	PANEL PORTAMANDOS	CONTROL HOLDER PANEL	2			
	Q152004000	TORNIL, APLASTADO M5x13 A304	FLAT HEADED BOLT M5x13 A304	4			
17	U862802000	PANEL LATERAL DERECHO	RIGHT SIDE PANEL	1			
	Q221342000	REMACHE EXAGONAL M5	HEXAGONAL RIVET M5	10			

Зип Общепит

vsezip.ru

812-987-08-81

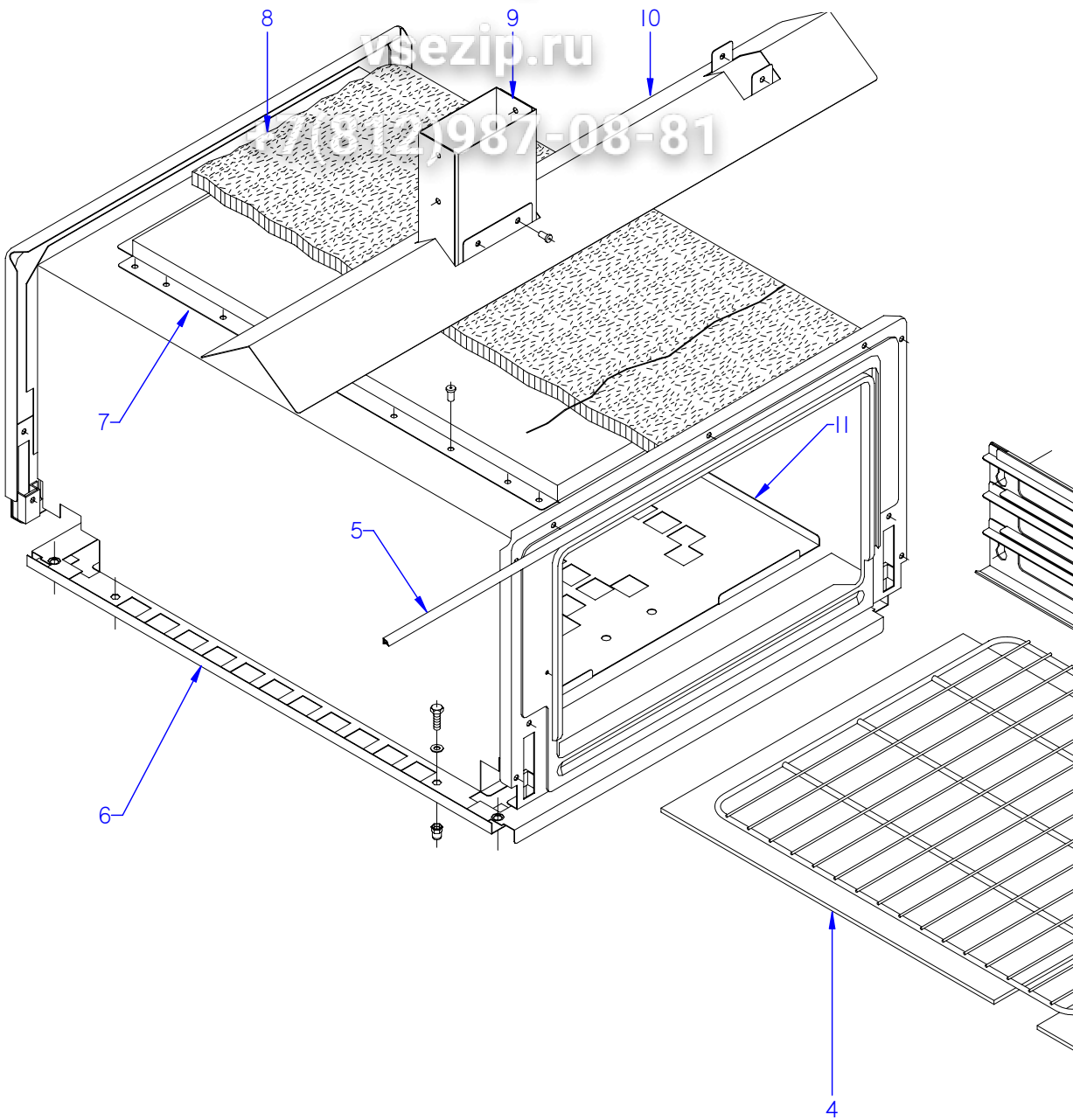

ITEM MARCADO EN COLOR = REPUESTO RECOMENDADO
COLOURED ITEM = RECOMMENDED SPARE PART

N plano	C-26889
Firma	
Fecha	2010-07
Aparato	HORNO PASANTE / THROUGH OVEN COCINAS / RANGES CG-1002
Lamina	2
Order	Fagor Industrial S. Coop.

Зип Общепит

vsezip.ru

+7(812)987-08-81

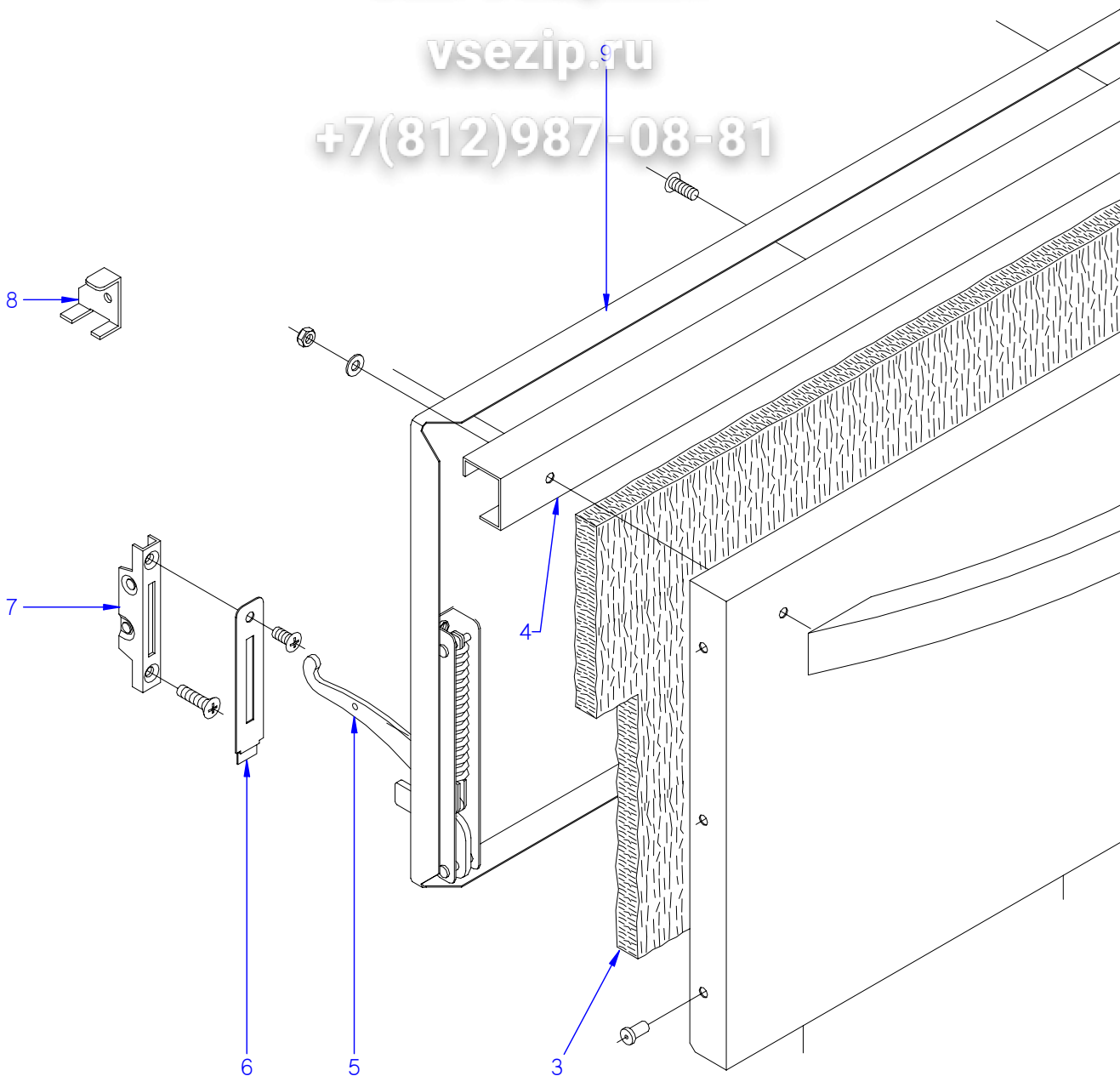

ITEM MARCADO EN COLOR = REPUUESTO RECOMENDADO
COLOURED ITEM = RECOMMENDED SPARE PART

N plano	Firma	Fecha	Aparato	PUERTA / DOOR	Lamina	Fogor Industrial S. Coop. FOGOR Orre
C-2690	<i>(Signature)</i>	2010-07	COCINAS / RANGES	CG-1002	3	

Зип Общепит

vsezip.ru

+7(812)987-08-81

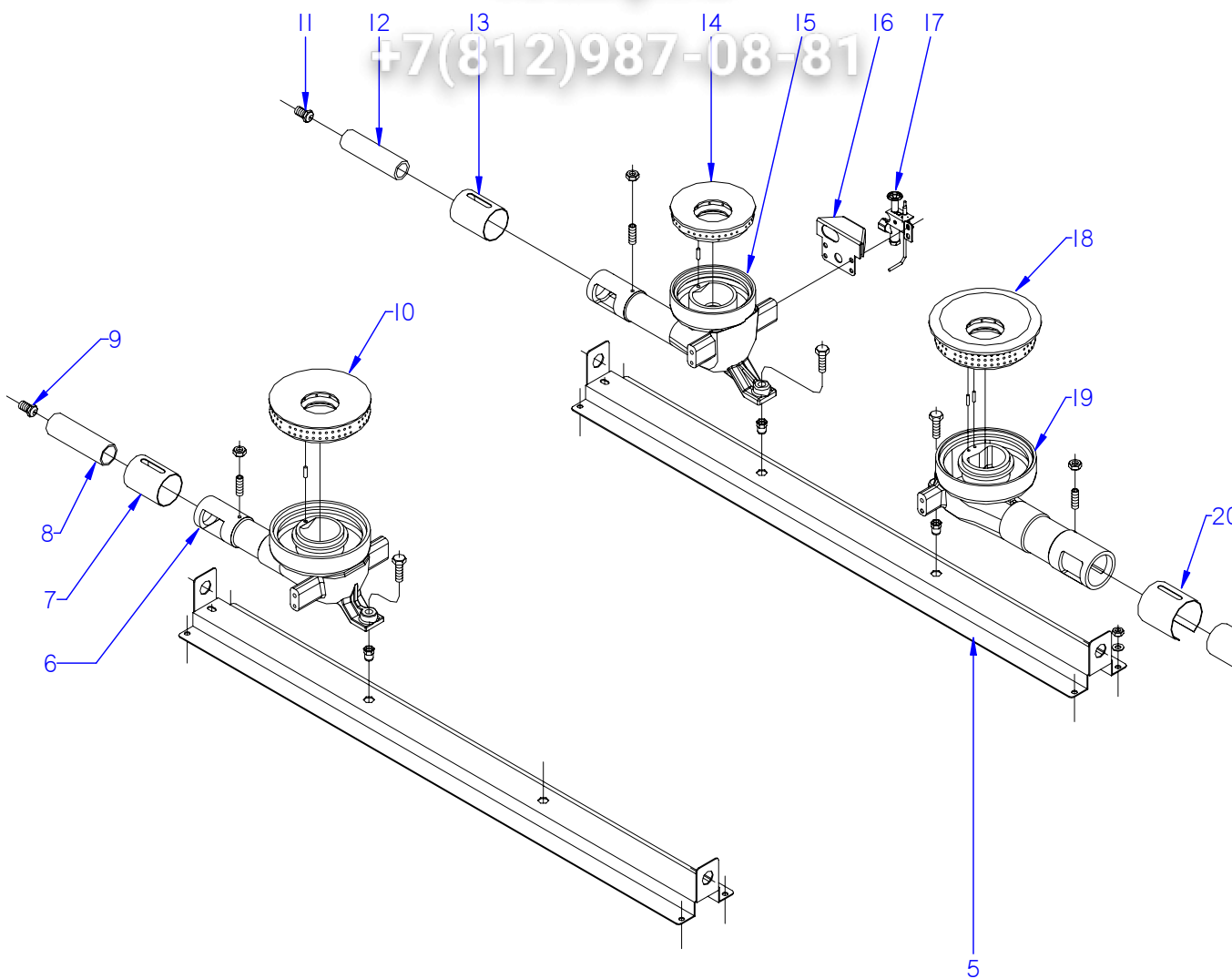

ITEM MARCADO EN COLOR = REPUESTO RECOMENDADO
COLOURED ITEM = RECOMMENDED SPARE PART

N plano	Firma	Fecha	Aparato	Lamina	Fogor Industrial s. Coop.
C-2691	<i>(Signature)</i>	2010-07	COCINAS / RANGES CG-1202	4	Onšte
			QUEMADORES / BURNERS		FAGOR

MOD.	COCINAS / RANGES	ZONA / ZONE	QUEMADORES / BURNERS				
ITEM	CODIGO CODE	DENOMINACION	NAME	CG-1002			
1	U325708000	DIFUSOR QUEMADOR HORNO	OVEN BURNER DIFFUSER	1			
	R252624000	PITON SOPORTE	PITON SUPPORT	1			
	Q162004000	TUERCA EXAGONAL M6	HEXAGONAL NUT M6	1			
	Q302022000	ARANDELA 16x6x1,2 A304	WASHER 16x6x1.2 A304	1			
2	U855700000	QUEMADOR HORNO	OVEN BURNER	1			
3	U325707000	REGULADOR DE AIRE	AIR CONTROL	1			
	Q012031000	TORNILLO EXAGONAL M5x10 A304	HEXAGONAL BOLT M5X10 A304	1			
4	N502401000	TOBERA Ø 1,70 B.P.	NOZZLE Ø 1,70 B.P.	1			
4	U054400000	TOBERA Ø 2,5 G.N.	NOZZLE Ø 2,5 G.N.	1			
4	942450000	TOBERA Ø 5,35 G.V.	NOZZLE Ø 5,35 G.V.	1			
5	U862604000	LISTON SOPORTE QUEMADOR	BURNER SUPPORT STRIP	2			
	Q162004000	TUERCA EXAGONAL M6	HEXAGONAL NUT M6	8			
	Q302022000	ARANDELA 16x6x1,2 A304	WASHER 16x6x1.2 A304	8			
6	U025702000	CUERPO QUEMADOR 8.000 Kcal/H	BURNER BODY 8.000 Kcal/H	1			
	Q371026000	MANGUITO DE SUJECION Ø 4x14	HANDLE Ø 4x14	1			
	Q131542000	VARILLA ROSCADA M6x15	THREADED ROD M6X15	1			
	Q162004000	TUERCA EXAGONAL M6	HEXAGONAL NUT M6	1			
7	U265702000	REGULADOR DE AIRE	AIR CONTROL	1			
8	U565700000	VENTURI QUEMADOR 8.000	BURNER VENTURI 8.000	1			
9	631000000	TOBERA Ø 1,40 B.P. (8.000)	NOZZLE Ø 1,40 B.P. (8.000)	1			
9	R614500000	TOBERA Ø 2 G.N. (8.000)	NOZZLE Ø 2 G.N. (8.000)	1			
9	U262401000	TOBERA Ø 4,10 G.V. (8.000)	NOZZLE Ø 4,10 G.V. (8.000)	1			
10	U135702500	QUEMADOR 8000	BURNER 8000	1			
11	U122407000	TOBERA Ø 1,05 B.P. (4.000)	NOZZLE Ø 1,05 B.P. (4.000)	2			
11	910510000	TOBERA Ø 1,5 G.N. (4.000)	NOZZLE Ø 1,5 G.N. (4.000)	2			
11	R302401000	TOBERA Ø 4 G.V. (4.000)	NOZZLE Ø 4 G.V. (4.000)	2			
12	U125720000	VENTURI QUEMADOR 4000	VENTURI BURNER 4000	2			
13	U265702000	REGULADOR DE AIRE	AIR CONTROL	2			
14	U445731000	QUEMADOR 4000 (00545-010)	BURNER 4000 (00545-010)	2			
14	12039162	QUEMADOR 4000 Kcal/H	BURNER 4000 Kcal/H	2			

MOD.	COCINAS / RANGES	ZONA / ZONE	QUEMADORES / BURNERS					
ITEM	CODIGO CODE	DENOMINACION	NAME	CG-1002				
15	U025701000	CUERPO QUEMADOR 4000 Kcal/H	BURNER BODY 4000 Kcal/H	2				
	Q371026000	MANGUITO DE SUJECION Ø 4x14	HANDLE Ø 4x14	2				
	Q131542000	VARILLA ROSCADA M6x15	THREADED ROD M6X15	2				
	Q162004000	TUERCA EXAGONAL M6	HEXAGONAL NUT M6	2				
16	U025708000	PROTECTOR PILOTO POSTERIOR	REAR GUARD PILOT	4				
	Q419005000	REMACHE 4X8 ALMG3 / ALUMINIO	RIVET 4X8 ALMG3 / ALUMINIUM	4				
17	11U4421340	CONJUNTO PILOTO COMPLETO	COMPLETE PILOT UNIT	4				
S/Nº	X012126000	CUERPO SIN RAC. 901.210	BODY WITHOUT CONNEC. 901.2	4				
S/Nº	U134323000	RACORD BICONO 6 958.031	BICONE CONNECTION 6 958.031	4				
S/Nº	U442132000	CABEZA PILOTO 975.016	PILOT HEAD 975.016	4				
S/Nº	U442131000	AMARRE DELANTERO PI 978.021	FRONT FASTENING PI 978.021	4				
S/Nº	U442130000	AMARRE TRASERO PI 978.009	REAR FASTEN. PI 978.009	4				
S/Nº	X012116000	TORNILLO AMA. 953.007	FAST. BOLT 953.007	4				
S/Nº	X012122000	REGULADOR AIRE 912.001	AIR CONTROL 912.001	4				
S/Nº	U442137000	INYECTOR Ø 0,4 GN	INJECTOR Ø 0.4 GN.	4				
18	U235701500	DIFUSOR 10.500 Kcal/H	DIFFUSER 10.500 Kcal/H	1				
18	12047137	DIFUSOR 10.500	DIFFUSER 10.500	1				
19	U025703000	CUERPO QUEMADOR 10000 Kcal/H	BURNER BODY 10000 Kcal/h	1				
	Q371028000	MANGUITO DE SUJECION Ø 3x14	HANDLE Ø 3x14	2				
	Q131542000	VARILLA ROSCADA M6x15	THREADED ROD M6X15	1				
	Q162004000	TUERCA EXAGONAL M6	HEXAGONAL NUT M6	1				
20	U025706000	REGULADOR DE AIRE 10.000	AIR CONTROL 10.000	1				
21	U235702000	VENTURI QUEMADOR 10.500	BURNER VENTURI 10,500	1				
22	U112401000	TOBERA Ø 1,55 B.P. (10.500)	NOZZLE Ø 1,55 B.P. (10.500)	1				
22	R275050000	TOBERA Ø 2,35 G.N. (10.500)	NOZZLE Ø 2,35 G.N. (10.500)	1				
22	U192402000	TOBERA Ø 4,90 G.V. (10.500)	NOZZLE Ø 4,90 G.V. (10.500)	1				

Зип Общепит

vsezip.ru

+7(812)987-08-81

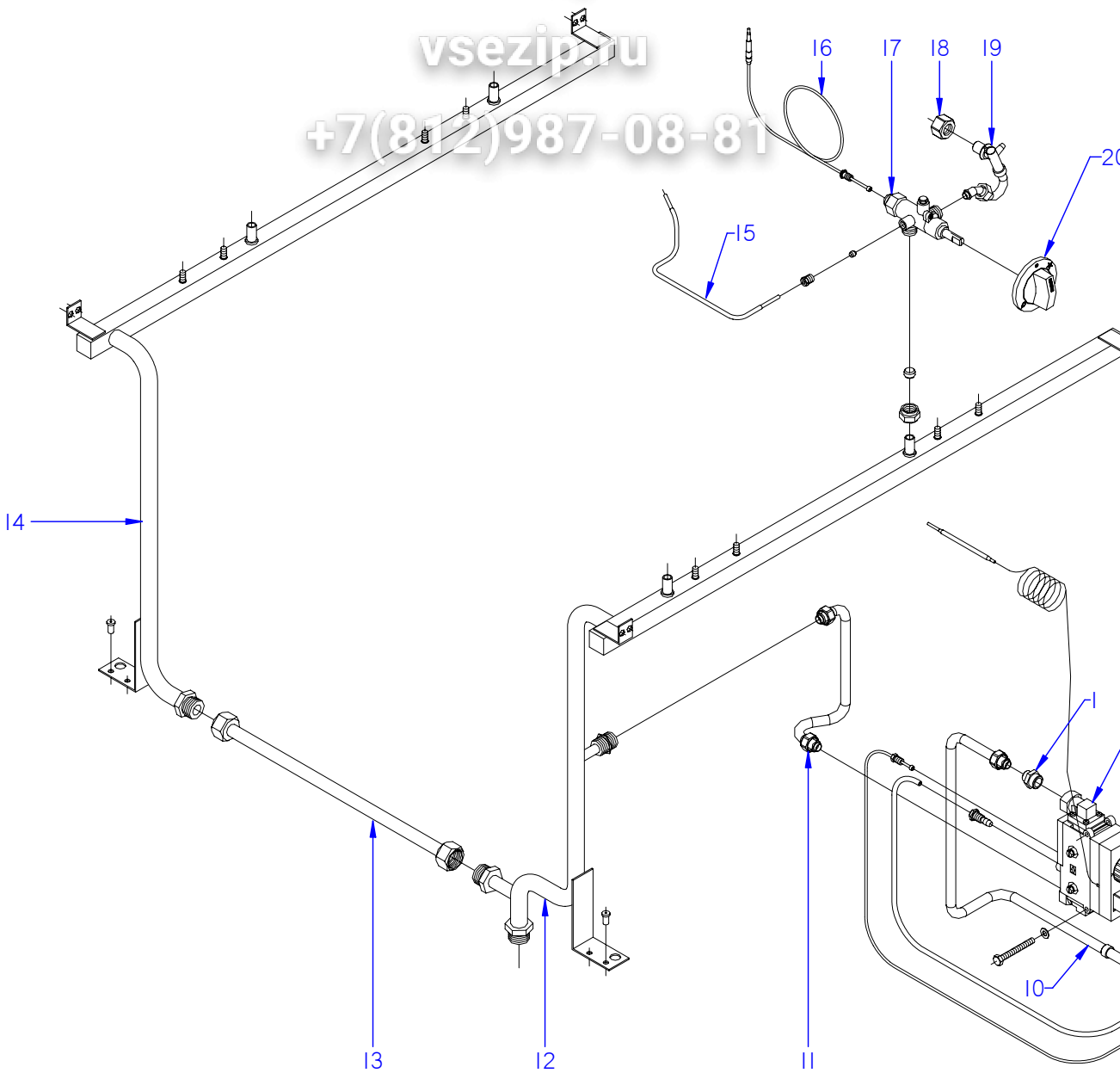

ITEM MARCADO EN COLOR = REPUUESTO RECOMENDADO
COLOURED ITEM = RECOMMENDED SPARE PART

N plano	Firma	Fecha	Aparato	Lamina	Fagor Industrial S. Coop. Onofre
C-2692		2010-07	PARTE FUNCIONAL GAS / GAS FUNCTIONAL PART COCINAS / RANGES CG-1002	5	

MOD.	COCINAS / RANGES	ZONA / ZONE	PARTE FUNCIONAL GAS GAS FUNCTIONAL PART				
ITEM	CODIGO CODE	DENOMINACION	NAME	CG-1002			
1	U875017000	MANGUITO R3/8"-R1/2"	HOSE R3/8"-R1/2"	2			
	U055043000	BICONO Ø 12	BICONE Ø 12	2			
2	U134324000	VALVULA MINISIT 0710.654	VALVE MINISIT 0710.654	1			
S/Nº	U134317000	MANDO NEGRO MINI 916.124	BLACK CTRL. MINI 916.124	1			
S/Nº	U134318000	CUBIERTA MINISIT 903.052	COVER MINISIT 903.052	1			
S/Nº	Q031322000	TORNILLO ALOMADO M4x15	CURVED SCREW M4X15	8			
S/Nº	U134323000	RACORD BICONO 6 958.031	BICONE CONNECTION 6 958.031	1			
S/Nº	U264300000	RACOR 3/8 906,252	CONNECTION 3/8 906.252	2			
S/Nº	Q307041000	JUNTA TORICA 25,4x20,2x2,6	O-RING 25.4x20.2x2.6	2			
3	U322118000	PILOTO COMPLETO BP 100.162	PILOT UNIT BP 100.162	1			
S/Nº	U442137000	INYECTOR Ø 0,4 GN	INJECTOR Ø 0.4 GN.	1			
4	X022131000	BUJIA	SPARK PLUG	1			
5	U323030000	CABLE BUJIA	SPARK PLUG CABLE	1			
6	U333003000	CABLE MASA ENCENDEDOR	LIGHTER EARTH CABLE	1			
7	S113034000	PIEZOELECTRICO	PIEZOELECTRIC	1			
7	12043897	PIEZOELECTRICO COMPLETO	COMPLETE PIEZOELECTRIC	1			
S/Nº	12043907	ANILLO ADAPTADOR	ADAPTER RING	1			
8	U565036000	TUBO PILOTO HORNO	PILOT PIPE BURNER	1			
	U134323000	RACORD BICONO 6 958.031	BICONE CONNECTION 6 958.031	2			
9	U562130000	TERMOPAR L=850	THERMOCOUPLE L=850	1			
10	U025017000	TUBO MINISIT A QUEMADOR	MINISIT BURNER PIPE	1			
	Q223019000	TUERCA 3/8 GAS LATÓN	NUT 3/8 BRASS GAS	1			
	U055043000	BICONO Ø 12	BICONE Ø 12	1			
	Q153002000	TORNILLO TAPON	SCREW CAP	1			
11	U025014000	TUBO EMPALME A MINISIT	SPLICE TUBE MINISIT	1			
12	U865000000	COND. GENERAL CG-1202 ANTER.	BEF. GENERAL PIPING CG-1202	1			
	Q411304000	REMACHE AVIBULB Ø 4,8	AVIBULB RIVET Ø 4.8	2			
13	U855010000	TUBO DISTRIBUIDOR COMPLETO	FULL DISTRIBUTOR PIPE	1			

