

Зип Общепит

vsezip.ru

DESPIECE TECNICO / SPARE PARTS BOM

+7(812)987-08-81

Baño maría
Bain marie
Bain marie
Bain maries
Bagno maria
Banho maria

GAMA 700 RANGE

Modelos / Models:

BMG7-10

BME7-05

BME7-10

Junio 2008 June

Revisado Mayo 2014 May Revised

FAGOR 

FAGOR INDUSTRIAL

Зип Общежит

vseparts.ru

+7(812)2987-08-81

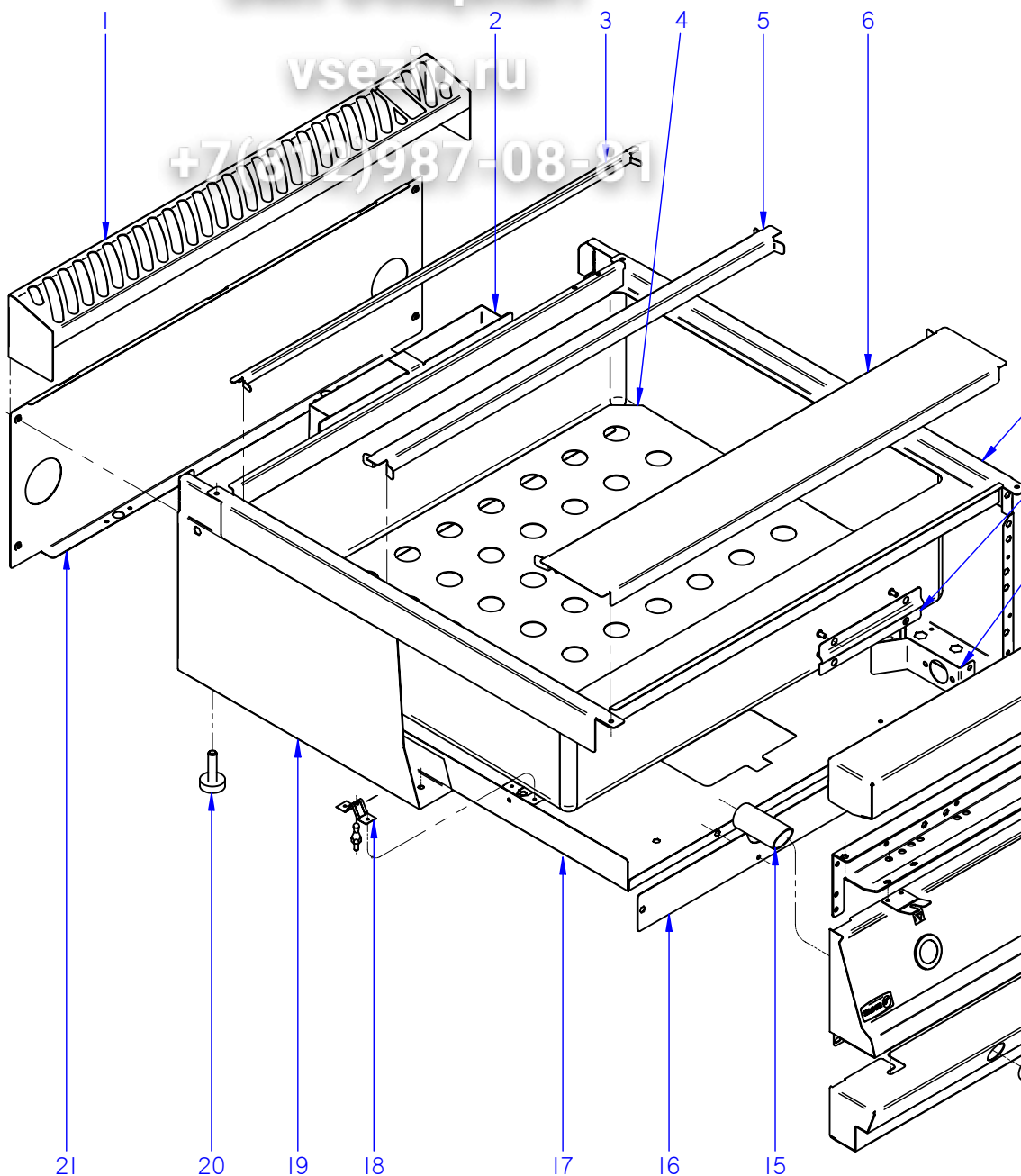

ITEM MARCADO EN COLOR = REPUESTO RECOMENDADO
COLOURED ITEM = RECOMMENDED SPARE PART

N plano	Firma	Fecha	Aparato	Lamina	Fagor Industrial S. Coop.
C-2100		2008-06	BAÑO MARIA G700	1	Onete
MUEBLE					



Зип Общепит

MOD.		BAÑO MARIA		ZONA	MUEBLE		
ITEM	CODIGO	DENOMINACION	TEXTO	BMG7-10	BME7-05	BME7-10	
1	H215402000	EMBELLECEDOR POSTERI. 1M BM	REAR TRIM. 1M BM	1	-	1	
1	H215401000	EMBELLECEDOR POSTER. 1/2M BM	REAR TRIM. 1/2M BM	-	1	-	
2	H212604000	SEMICHIMENEA ANTERIOR	FRONT SEMI-FLUEPIPE	1	-	-	
	H312606000	SEMICHIMENEA POSTERIOR	REAR SEMI-FLUEPIPE	1	-	-	
	Q419005000	REMACHE 4x8 ALMG3 / ALUMINIO	RIVET 4X8 ALMG3 / ALUMINIUM	10	-	-	
3	H316111000	SEPAR. CUBETAS POSTERIOR 1M	REAR TRAY DIVIDER 1M	1	-	1	
3	H326107000	SEPAR. CUBETAS POSTERIOR 1/2M	REAR TRAY DIVIDER 1/2M	-	1	-	
4	H216125000	PANEL SEPARADOR BM 710 Q	PANEL DIVIDER BM 710 Q	1	-	1	
4	H216115000	PANEL SEPARADOR BM 705 Q	PANEL DIVIDER BM 705 Q	-	1	-	
5	R986105000	SEPARADOR DE CUBETAS	TRAY DIVIDER	2	-	2	
5	R966104000	SEPARADOR DE CUBETAS	TRAY DIVIDER	-	2	-	
6	H216124000	PROTECTOR REBOSADERO	OVERFLOW GUARD	1	-	1	
6	H216106000	PROTECTOR REBOSADERO	OVERFLOW GUARD	-	1	-	
7	H216120000	CUBA COMPLETA BMG7-10	COMPLETE TUB BMG7-10	1	-	-	
7	H216105000	CUBA COMPLETA BME7-05	COMPLETE TUB BME7-05	-	1	-	
7	H216123000	CUBA COMPLETA BME7-10	COMPLETE TUB BME7-10	-	-	1	
	Q012031000	TORNILLO EXAGONAL M5x10 A304	HEXAGONAL BOLT M5x10 A304	4	4	4	
	Q302022000	ARANDELA 16x6x1,2 A304	WASHER 16x6x1.2 A304	4	4	4	
8	H316112000	PROTECCION BULBO	BULB PROTECTION	1	1	1	
	Q162030000	TUERCA EXAGONAL M5	HEXAGONAL NUT M5	4	4	4	
	Q232030000	ARANDELA A5	WASHER A5	4	4	4	
9	Z201101000	ESCUADRA AMARRE ELECTROVA	SOLENOID VALVE BRACKET	1	1	1	
	Q152004000	TORNILLO APLASTADO M5x13 A304	FLAT HEADED BOLT M5x13 A304	2	2	2	
	Q306039000	ARANDELA JUNTA Ø23,8x16,2x1,5	WASHER SEAL Ø23.8x16.2x1.5	2	2	2	
	Q162030000	TUERCA EXAGONAL M5	HEXAGONAL NUT M5	2	2	2	
10	H125409000	ANTERIOR MESA 1M G-700	FRONT BENCH 1M G-700	1	-	1	
10	H125403000	ANTERIOR MESA 1/2M G-700	FRONT BENCH 1/2M G-700	-	1	-	
	Q152004000	TORNILLO APLASTADO M5x13 A304	FLAT HEADED BOLT M5x13 A304	2	2	2	
	Q302022000	ARANDELA 16x6x1,2 A304	WASHER 16x6x1.2 A304	2	2	2	

Зип Общепит

MOD.		BAÑO MARIA		ZONA		MUEBLE	
ITEM	CODIGO	DENOMINACION	TEXTO	BMG7-10	BME7-05	BME7-10	
11	H602603000	ESCUADRA AMARRE ANTERIOR 1 M	FRONT BRACKET FASTENING 1	1	-	1	
11	H602602000	ESCUADRA AMARRE ANTERI. 1/2 M	FRONT FASTENING BRACKET 1	-	1	-	
	Q012031000	TORNILLO EXAGONAL M5x10 A304	HEXAGONAL BOLT M5x10 A304	6	6	6	
	Q221342000	REMACHE EXAGONAL M5	HEXAGONAL RIVET M5	6	6	6	
	Q302022000	ARANDELA 16x6x1,2 A304	WASHER 16x6x1.2 A304	6	6	6	
12	H212811000	PORTAMANDOS COMPL. BMG-710Q	CONTROL HOLDER BMG-710Q	1	-	-	
12	H212808000	PORTAMANDOS COMPL. BME-705	CONTROL HOLDER BME-705	-	1	-	
12	H212815000	PORTAMANDOS COMPL. BME-710	CONTROL HOLDER BME-710	-	-	1	
	Q152004000	TORNIL. APLASTADO M5X13 A 304	FLAT HEADED SCREW M5x13 A	4	4	4	
	Q221343000	REMACHE EXAGONAL M6	HEXAGONAL RIVET M6	2	2	2	
	U912805000	ESCUDO FAGOR G700	FAGOR EMBLEM G700	1	1	1	
	Q221023000	CLIP SUJECIÓN RÁPIDA Ø5	RAPID CONNECT CLIP Ø5	2	2	2	
13	H212813000	ZOCALO BMG7-10 Q	SKIRTING BMG7-10 Q	1	-	-	
13	H602803000	ZOCALO 7-05 Q	SKIRTING 7-05 Q	-	1	-	
13	H602816000	ZOCALO 7-10 Q	SKIRTING 7-10 Q	-	-	1	
	Q151336000	TORNILLO SOPORTE GUIAS	GUIDE SUPPORT BOLT	2	2	2	
	Q221343000	REMACHE EXAGONAL M6	HEXAGONAL RIVET M6	4	4	4	
	Q012031000	TORNILLO EXAGONAL M5x10 A304	HEXAGONAL BOLT M5x10 A304	2	2	2	
	Q302022000	ARANDELA 16x6x1,2 A304	WASHER 16x6x1.2 A304	2	2	2	
14	H212821000	EMBELLECED. TUBO ENCENDIDO	IGNITION PIPE TRIM	1	-	-	
15	H212819000	DISTANCIADOR	SPACER	1	-	-	
	Q306027000	ARANDELA PLANA 33.8X27X1.5	FLAT WASHER 33.8X27X1.5	1	-	-	
	Q221324000	TUERCA 3/4 GAS	NUT 3/4 GAS	1	-	-	
16	H212603000	TAPA BASE	BASE COVER	1	-	-	
	Q221341000	REMACHE EXAGONAL M4	HEXAGONAL RIVET M4	2	-	-	
	Q152004000	TORNIL. APLASTADO M5X13 A 304	FLAT HEADED SCREW M5x13 A	2	-	-	
17	H212806000	BASE BMG-710	BASE BMG-710	1	-	-	
17	H212805000	BASE BME-705	BASE BME-705	-	1	-	
17	H212816000	BASE BME-710	BASE BME-710	-	-	1	
	Q419005000	REMACHE 4x8 ALMG3 / ALUMINIO	RIVET 4X8 ALMG3 / ALUMINIUM	8	8	8	
	Q221342000	REMACHE EXAGONAL M5	HEXAGONAL RIVET M5	6	6	6	

Зип Общежит

vsezip.ru

+7(812)987-08-81

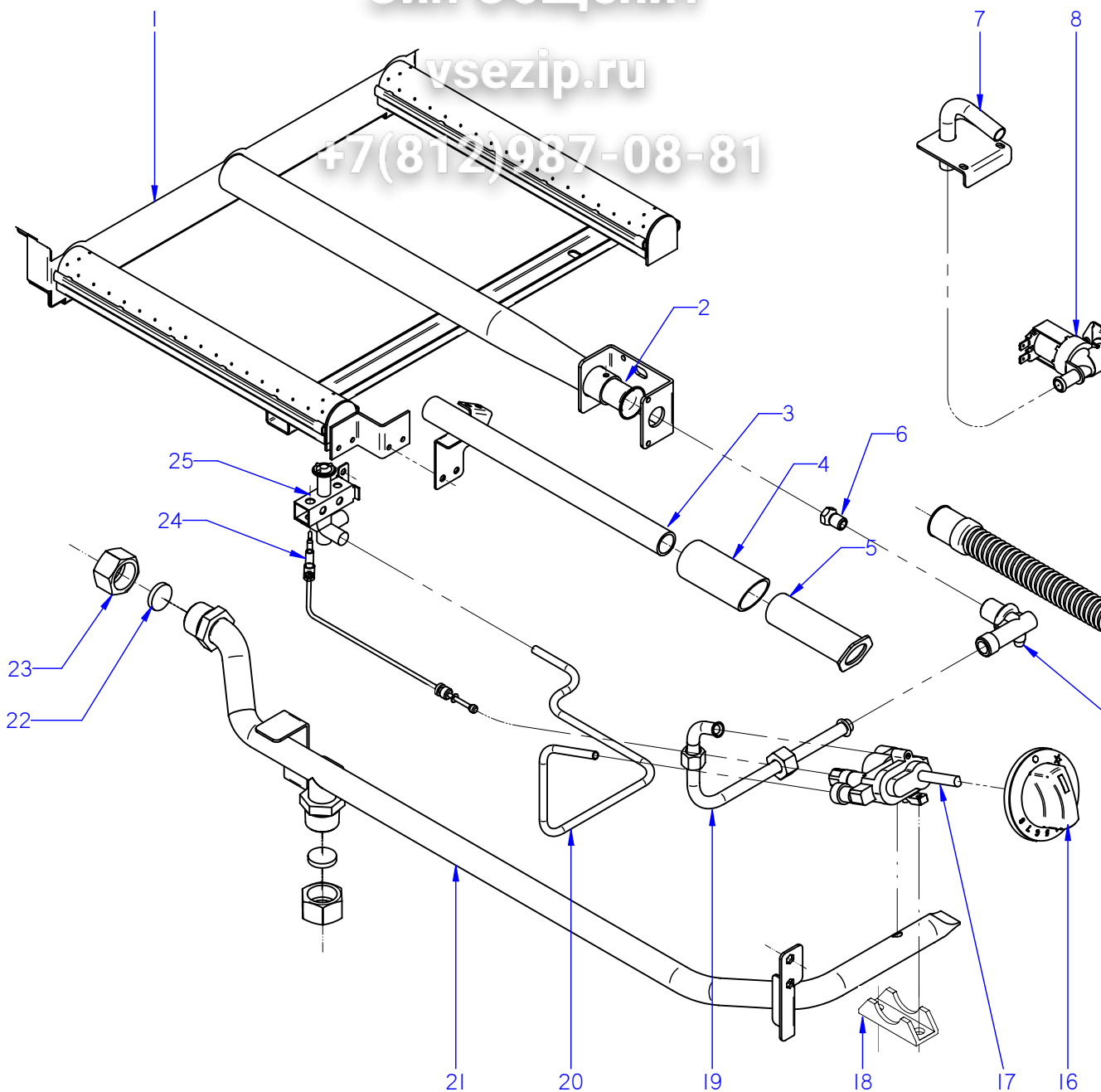

ITEM MARCADO EN COLOR = REPUUESTO RECOMENDADO
COLOURED ITEM = RECOMMENDED SPARE PART

N plano	C-2101
Firma	
Fecha	2008-06
Aparato	BAÑO MARIA VMG7-10
PARTE FUNCIONAL	
Lamina	2
Fagor Industrial S. Coop. Onate	

Зип Общепит

MOD.		BAÑO MARIA		ZONA vsezip.ru		PARTE FUNCIONAL			
ITEM	CODIGO	DENOMINACION	TEXTO	BMG7-10					
1	H215707000	QUEMADOR COMPLETO BMG-710	COMPLETE BURNER BMG-710	2					
2	U325707000	REGULADOR DE AIRE	AIR REGULATOR	1					
	Q012031000	TORNILLO EXAGONAL M5x10 A304	HEXAGONAL BOLT M5x10 A304	3					
3	H215704000	TUBO ENCENDIDO COMPLETO	COMPLETE IGNITION PIPE	1					
	Q012031000	TORNILLO EXAGONAL M5x10 A304	HEXAGONAL BOLT M5x10 A304	2					
4	H212819000	DISTANCIADOR	SPACER	1					
	Q306027000	ARANDELA PLANA 33.8X27X1.5	FLAT WASHER 33.8X27X1.5	1					
	Q221324000	TUERCA 3/4 GAS	NUT 3/4 GAS	1					
5	H212821000	EMBELLECED. TUBO ENCENDIDO	IGNITION PIPE TRIM	1					
6	R422400000	TOBERA Ø 1,25 (But.-Prop.)	NOZZLE Ø1.25 (BUT-PROP.)	1					
6	9429500000	TOBERA Ø 1,90 (Gas Natural)	NOZZLE Ø1.90 (NATURAL GAS)	1					
6	U192402000	TOBERA Ø 4,90 (Gas Villa)	NOZZLE Ø4.90 (City gas)	1					
7	H216127000	TUBO LLENADO	FILLER PIPE	1					
	Q419005000	REMACHE 4x8 ALMG3 / ALUMINIO	RIVET 4X8 ALMG3 / ALUMINIUM	2					
S/Nº	3676900000	TUBO GOMA NEGRA Ø 17*10	BLACK RUBBER PIPE 17*10	1					
	Q881302000	ABRAZADERA Ø 12/20	CLAMP 12/20	2					
8	Z701135000	E.V.SIMP.220V COD.255.208	E.V.SIMP.220V COD.255.208	1					
	Z601156000	REGULADOR 8L RO. 254.034	REGULATOR 8L RED 254.034	1					
	12096626	REGULADOR 8 L (ROJO)	REGULATOR 8 L (RED)	1					
	Q032021000	TORNILLO ALOMADO M4X10	CURVED SCREW M4X10	2					
9	H216111000	REBOSADERO	OVERFLOW	1					
	Q306038000	ARANDELA JUNTA Ø31X21X1.5	WASHER SEAL Ø31X21X1.5	2					
10	T343008000	CONMUTADOR HGC	HGC SWITCH	1					
	Q151320000	TOR. ALOMADO M4X6 H.ZINCADO	CURVED SCREW M4X6 H. ZINC	2					
11	H212103000	BOTON DE MANDO Ø6 (EN. AGUA)	CONTROL BUTTON Ø6 (WATER	1					
12	H216109000	GUIA REBOSADERO	OVERFLOW GUIDE	1					
13	H216110000	TUERCA GUIA REBOSADERO	OVERFLOW GUIDE NUT	1					
14	Z220903000	MANGUERA DESAGÜE	DRAINAGE HOSE	1					
	Q881305000	ABRAZADERA Ø 25-40	CLAMP Ø25-40	1					
15	U265033000	PORTATOBERAS HORNO Ø10	OVER NOZZLE HOLDER Ø10	1					
16	H212101000	BOTON DE MANDO Ø8 BMG700	CONTROL BUTTON Ø8 BM G700	1					

Зип Общепит

vsezip.ru

+7(812)987-08-81

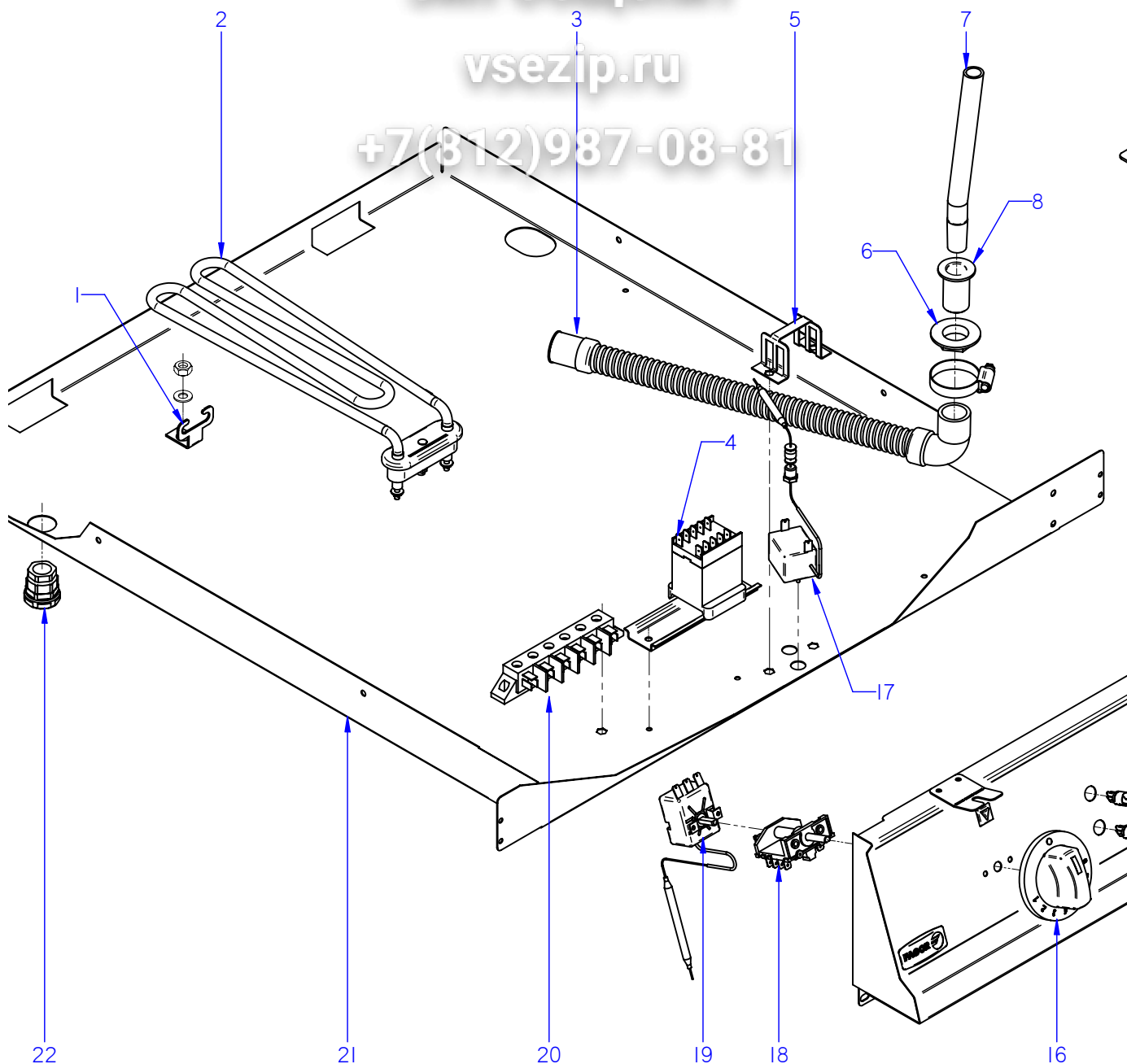

ITEM MARCADO EN COLOR = REPUUESTO RECOMENDADO
COLOURED ITEM = RECOMMENDED SPARE PART

N plano	Firma	Fecha	Aparato	PARTE FUNCIONAL	Lamina	Fagor Industrial S. Coop.
C-2102	<i>(Signature)</i>	2008-06	BAÑO MARIA BME7-05 / BME7-10		3	Onete



MOD.		BAÑO MARIA		ZONA		PARTE FUNCIONAL			
ITEM	CODIGO	DENOMINACION	TEXTO	BME7-05	BME7-10				
1	Z603602000	SOPORTE RESISTENCIA TANQUE	TANK RESISTOR SUPPORT	1	3				
	Q162030000	TUERCA EXAGONAL M5	HEXAGONAL NUT M5	1	3				
	Q232030000	ARANDELA A5	WASHER A5	1	3				
2	R223005000	RESISTENCIA TANQUE	TANK RESISTOR	1	3				
3	Z220903000	MANGUERA DESAGÜE	DRAINAGE HOSE	1	1				
	Q881305000	ABRAZADERA Ø 25-40	CLAMP Ø25-40	1	1				
4	Z213007000	CONTACTOR 3F2010-3AL2	CONTACTOR 3F2010-3AL2	—	1				
	R663055000	GUIA CONTACTOR L-120	CONTACTOR GUIDE L-120	—	1				
	Q221342000	REMACHE EXAGONAL M5	HEXAGONAL RIVET M5	—	2				
	Q152004000	TORNILLO APLASTADO M5x13 A304	FLAT HEADED BOLT M5x13 A30	—	2				
5	Z203060000	AMARRE LIMITADOR	LIMITER FASTENING	1	1				
	Q152004000	TORNILLO APLASTADO M5x13 A304	FLAT HEADED BOLT M5x13 A30	2	2				
6	H216110000	TUERCA GUIA REBOSADERO	OVERFLOW GUIDE NUT	1	1				
7	H216111000	REBOSADERO	OVERFLOW	1	1				
	Q306038000	ARANDELA JUNTA Ø31X21X1.5	WASHER SEAL Ø31X21X1.5	2	2				
8	H216109000	GUIA REBOSADERO	OVERFLOW GUIDE	1	1				
9	H216127000	TUBO LLENADO	FILLER PIPE	1	1				
	Q419005000	REMACHE 4x8 ALMG3 / ALUMINIO	RIVET 4X8 ALMG3 / ALUMINIUM	2	2				
S/Nº	3676900000	TUBO GOMA NEGRA Ø 17*10	BLACK RUBBER PIPE 17*10	1	1				
	Q881302000	ABRAZADERA Ø 12/20	CLAMP 12/20	2	2				
10	Z701135000	E.V.SIMP.220V COD.255.208	E.V.SIMP.220V COD.255.208	1	1				
	Z601156000	REGULADOR 8L RO. 254.034	REGULATOR 8L RED 254.034	1	1				
	12096626	REGULADOR 8 L (ROJO)	REGULATOR 8 L (RED)	1	1				
11	T343008000	CONMUTADOR HGC	HGC SWITCH	1	1				
	Q151320000	TOR. ALOMADO M4X6 H.ZINCADO	CURVED SCREW M4X6 H. ZINC	2	2				
12	R693055000	PILOTO VERDE 41227000C7	GREEN PILOT 41227000C7	1	1				
	12047390	PILOTO VERDE 230V AC 8KW 16MM	GREEN PILOT 230V AC 8KW 16	1	1				
13	H212103000	BOTON DE MANDO Ø6 (EN. AGUA)	CONTROL BUTTON Ø6 (WATER)	1	1				
14	H212808000	PORTAMANDOS COMPL. BME-705	CONTROL HOLDER BME-705	1	—				
14	H212815000	PORTAMANDOS COMPL. BME-710	CONTROL HOLDER BME-710	—	1				

MOD.		BAÑO MARIA		ZONA		VARIOS	
ITEM	CODIGO	DENOMINACION	TEXTO	BMG7-10	BME7-05	BME7-10	
	H316500000	FOLLETO INSTRUCCIONES BMG	INSTRUCTION LEAFLET BMG	1	-	-	
	H316501000	FOLLETO INSTRUCCIONES BMG	INSTRUCTION LEAFLET BMG	1	-	-	
	H213009000	ESQ. TEORICO ADHESIVO BMG710	THEORETICAL DIAG. LABEL BM	1	-	-	
	H213008000	ESQUEMA DE MONTAJE BMG710	ASSEMBLY DIAGRAM BMG710	1	-	-	
	H213007000	CABLEAD. PORTAMANDOS BMG710	WIRING CONTROL HOLDER BM	1	-	-	
	H213004000	CABL. CONMUTADOR- ELECTROVA	CABLE. SWITCH-SOLENOID VA	1	-	-	
	H213010000	CABLEAD. VALVULA AGUA BM 700 EA	WATER VALVE WIRING BM 700	1	-	-	
	H326500000	FOLLETO DE INSTRUCCIONES BME	INSTRUCTION LEAFLET BME	-	1	1	
	H366501000	FOLLETO DE INSTRUCCIONES BME	INSTRUCTION LEAFLET BME	-	1	1	
	H213002000	ESQUEMA TEORICO ADH. BME705	THEORETICAL DIAGRAM ADH. B	-	1	-	
	J183003000	ESQUEMA TEORICO BME6-05	THEORETICAL DIAG. BME6-05	-	1	-	
	H213006000	ESQUEMA TEORICO ADH. BME710	THEORETICAL DIAGRAM	-	-	1	
	J153003000	ESQUEMA TEORICO FE6-05,CMF6-05	THEORETICAL DIAGRAM	-	-	1	
	H213003000	ESQUEMA DE MONTAJE BME	ASSEMBLY DIAGRAM BME	-	1	-	
	J303002000	ESQUEMA DE MONTAJE BM	ASSEMBLY DIAGRAM BM	-	1	-	
	H213003000	ESQUEMA DE MONTAJE BME	ASSEMBLY DIAGRAM BME	-	-	1	
	R223003000	CABLEADO CONT. RES. FI-6 Y 8	WIRING CONT. RES. FI-6 & 8	-	-	1	
	H213005000	CABLEAD. REGLETA CONMUTADOR	WIRING SWITCH STRIP	-	-	1	
	R223002000	CABLEADO REGLETA CONTACTOR	CONTACTOR STRIP WIRING	-	-	1	
	H213004000	CABL. CONMUTADOR- ELECTROVA	CABLE. SWITCH-SOLENOID VA	-	1	1	
	H213010000	CABLEAD. VALVULA AGUA BM 700 EA	WATER VALVE WIRING BM 700	-	1	1	
	H213001000	CABLEAD. MANDO-BME7-05	WIRING CONTROL HOLDER BM	-	1	-	
	R223006000	CABLEAD. PORTAMANDOS BME 910	WIRING CONTROL HOLDER BM	-	-	1	
	J183002000	INSTALACION ELECTRICA BME6-05	ELECT. INSTALLATION BME6-05	-	1	-	
	12046142	CABLE. TENSOR PORTAMANDOS	WIRING TENSOR PORTAMAND.	-	1	1	

Зип Общепит

MOD.	BAÑO MARIA	ZONA	PIEZAS ESPECIFICAS PARA LOS DIST GASES
-------------	-------------------	-------------	---

ITEM	CODIGO	DENOMINACION	TEXTO	BMG7-10			
		<u>BUTANO - PROPANO</u>	<u>BUTANE - PROPANE</u>				
6	R422400000	TOBERA Ø 1,25	NOZZLE Ø 1.25	1			
S/N	U136501000	INDICADOR (BUTANO-PROPANO)	INDICATOR (BUTANE-PROPANE)	1			
		<u>GAS NATURAL</u>	<u>NATURAL GAS</u>				
6	9429500000	TOBERA Ø 1,90	NOZZLE Ø 1.90	1			
25	U442137000	INYECTOR Ø 0,40	INJECTOR Ø 0.40	1			
S/N	U134402000	INDICADOR GAS NATURAL	INDICATOR GAS NATURAL	1			
		<u>GAS VILLA</u>	<u>TOWN GAS</u>				
6	U192402000	TOBERA Ø 4,90 GAS VILLA	NOZZLE Ø4.90 (Town gas)	1			
S/N	U134310000	INDICADOR GAS VILLA	INDICATOR TOWN GAS	1			

MOD.		BAÑO MARIA		ZONA	REPUESTOS RECOMENDADOS RECOMMENDED SPARE PART		
ITEM	CODIGO	DENOMINACION	TEXTO	BMG7-10	BME7-05	BME7-10	
8	Z701135000	E.V.SIMP.220V COD.255.208	E.V.SIMP.220V COD.255.208	1	-	-	
10	T343008000	CONMUTADOR HGC	HGC SWITCH	1	-	-	
	Q151320000	TOR. ALOMADO M4X6 H.ZINCADO	CURVED SCREW M4X6 H. ZINC	2	-	-	
12	H216109000	GUIA REBOSADERO	OVERFLOW GUIDE	1	-	-	
13	H216110000	TUERCA GUIA REBOSADERO	OVERFLOW GUIDE NUT	1	-	-	
14	Z220903000	MANGUERA DESAGÜE	DRAINAGE HOSE	1	-	-	
17	H352101000	TERMOSTATO MTZ-22300	THERMOSTAT MTZ-22300	1	-	-	
24	U222130000	TERMOPAR L=600	THERMOCOUPLE L=600	1	-	-	
25	U322118000	PILOTO COMPLETO 100,062	COMPLETE PILOT LIGHT 100.06	1	-	-	
	U442137000	INYECTOR Ø 0,40 (Gas Natural)	NOZZLE Ø0.4 (GAS NATURAL)	1	-	-	
2	R223005000	RESISTENCIA TANQUE	TANK RESISTOR	-	1	3	
3	Z220903000	MANGUERA DESAGÜE	DRAINAGE HOSE	-	1	1	
6	H216110000	TUERCA GUIA REBOSADERO	OVERFLOW GUIDE NUT	-	1	1	
8	H216109000	GUIA REBOSADERO	OVERFLOW GUIDE	-	1	1	
9	H216127000	TUBO LLENADO	FILLER PIPE	-	1	1	
10	Z701135000	E.V.SIMP.220V COD.255.208	E.V.SIMP.220V COD.255.208	-	1	1	
11	T343008000	CONMUTADOR HGC	HGC SWITCH	-	1	1	
12	12047390	PILOTO VERDE 230V AC 8KW 16MM	GREEN PILOT 230V AC 8KW 16	-	1	1	
15	12024669	PILOTO AMBAR Ø18	AMBER PILOT Ø18	-	1	1	
17	Z213014000	TERMOSTATO LIMITADOR	THERMOSTAT LIMITER	-	1	1	
18	X163007000	CONMUT. ACOPLA TERMOSTATO	THERMOSTAT CONNECTION SV	-	1	1	
19	Z203014000	TERMOSTATO CALDERIN	WASH DRUM THERMOSTAT	-	1	1	

Зип Общепит

vsezip.ru

+7(812)987-08-81

Зип Общепит

vsezip.ru

+7(812)987-08-81

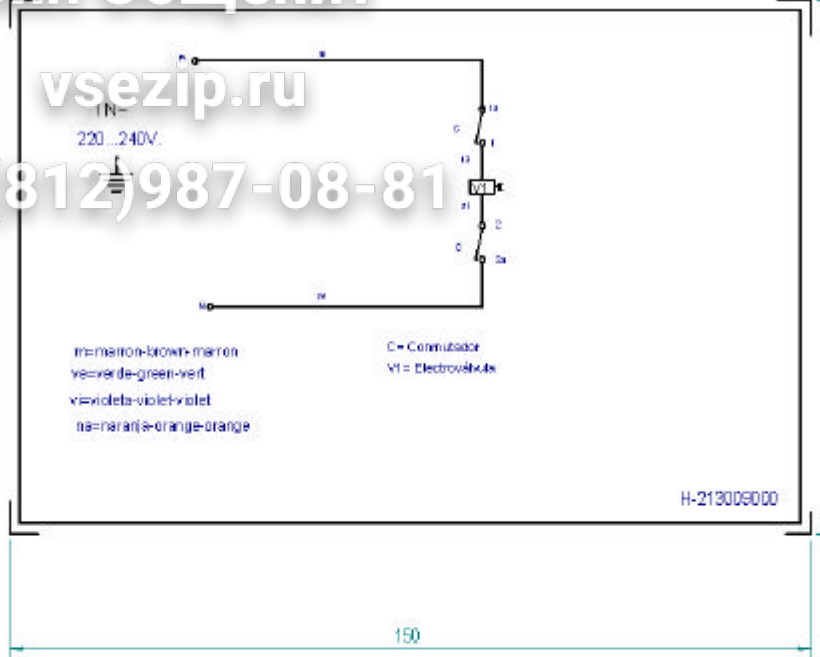

NOTA: - LAS INSCRIPCIONES RESISTIRAN SIN MODIFICACION APRECIABLE, EL FROTAMIENTO DURANTE 15 SEG. DE UN ALGODON EMPAPADO EN GASOLINA.

Plastico blanco alto brillo

Esquema tecnico adhesivo BMG7.10		H213009000	
Nº	Pieza	Materia	Nº Clasificacion
Nº	Modificacion	Propuesta de	Fecha
			Tolerancias generales
			≤ 5 : 5.0-10.0 $5-25 \pm$: ≥ 10.0 $25-50 \pm$: ∞
Dibujado	jaqaba	Fecha	2007-07-08
Proyectado	jaqaba	Fecha	2007-07-08
Comprobado	jaqaba	Fecha	2007-07-08
Escala			
BAÑO-MARIA Plano blanco adhesivo usado en laminado por laminado gris			Mecanizado superficial Plano numero HB-74441 Sustituye al Nº Sustituido por



Fagor Industrial,oop.Ek., Mugelua

BME 905, 705, 705 EA, 605, EM 49 ESBME 40, EBM 350, 400, 400 BL

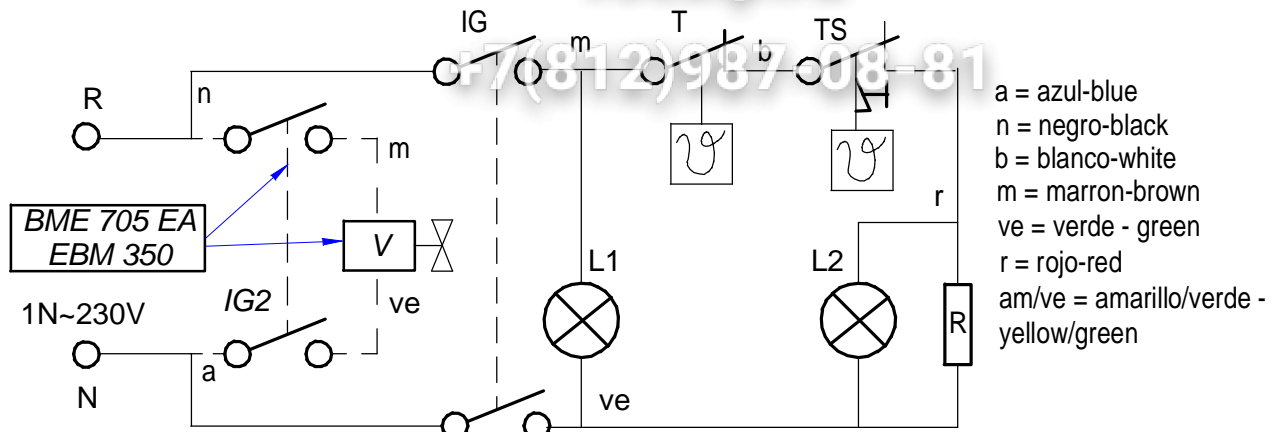

L1: Luz de encendido/Operation lamp
 TS: Termostato de seguridad/Security thermostat
 IG, IG2: Interruptor general/Main switch
 V: Electrovalvula de agua/Water inlet

L2: Luz de calentamiento/Heating lamp
 T: Termostato regulable/Adjustable thermostat
 R: Resistencia/Resistance

J183003000

-	Theoretical diagram: BM6-05		-	-	J183003000	-
Zk./Nº	Pieza		Cant.	Materiala/Material	Klas. zk/Nº Clas.	Gainazal akabera/Tratamiento
Zk./Nº	Aldaketa/Modificaciones		Nork proposatua/Propuesta de		Data/Fecha	Perdoi orokorrak Tolerancias generales
-	-	-	-	-	-	< 5 ± 0.2 50 ÷ 100 ± 0.8
-	-	-	-	-	-	5 ÷ 25 ± 0.4 >100± 1
-	-	-	-	-	-	25 ÷ 50 ± 0.6 α ± 1
-	-	-	-	-	-	-
Marratzua/Dibujado	Sinadura/Firma	Data/Fecha	 Fagor Industrial, Koop. Elk, Mugatua			Gainazal perdoia Mecanizado superficial
Proiektatua/Proyectado	e.carrascal	2008-10-23				-
Egiatzatua/Comprobado	<i>I.Alberdi</i>	2008-10-23				-
Eskala/Escala	COOKING					Plano Zk./Plano Nº HB-80491
-	Plano hau ezin daiteke erabili, ez berriztatu, gure baimenik gabe.					- Zk. ord. du
-						- Zk.gaitik ord.

Зип Общепит

BME9-10 BME-710

vsezip.ru

+7(812)987-0801

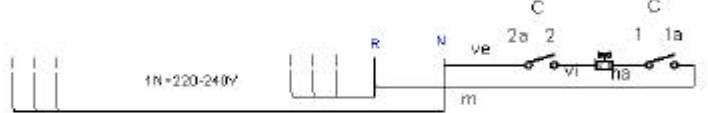
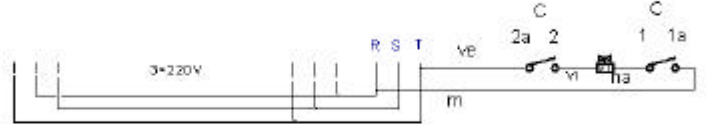
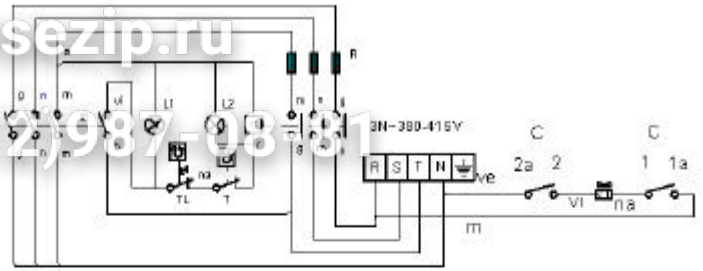

- r = rojo-rojo
- m = marrón-oscuro-marrón
- g = gris-gris gris
- n = negro-oscuro-oscuro
- g = azul-azul-oscuro
- b = blanco-oscuro-blanco
- am/ro = amarillo-rojo
- yl/g/m = amarillo-verde/verde/verde
- pa/m/ro = pardo/marrón-rojo
- ve = verde-oscuro-verde
- v = violeta-oscuro-violeta
- na = naranja-oscuro-naranja
- m = marrón-oscuro-marrón
- IG: Interruptor general
- L1: Lámpara fluorescente
- T: Termostato regulable (50-90 °C)
- L2: Lámpara calentamiento
- C: Condensador de calentamiento
- R: Resistencia
- TL: Termostato limitado
- D: Condensador
- VI: Electroválvula

H213006000

Esquema teórico adhesivo BME7-10 c/ agua				H213006000	
Nº	Pieza	Cont.	Material	Nº Clasificación	Acabado
Nº	Modificación	Propuesta de		Fecha	Tolerancias generales
					$\leq +$: 50-100 $\leq -$: ≥ 100 \pm : ∞
Dibujado	Firma	Fecha	 Façor Industrial, R.o.p. E.R., Muguelas		Mecanizado superficial
Proyectado	algibez	2007.07.09			
Comprobado					
Escala					
				Plano número HB-74440	
Plano hecho en el taller de planos por ordenador gpa				Sustituye al Nº Sustituido por	

Зип Общедит

BME 910, BME 710, BME 710 EA

FTE, FE 6 05, CMF 6-05

vsezip.ru

+7(812)981-1181

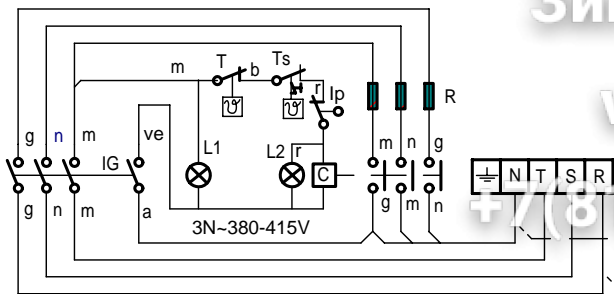

- r = rojo / red
- m = marron / brown
- g = gris / grey
- n = negro / black
- a = azul / blue
- b = blanco / white
- ve = verde / Green
- am/ve = amarillo-verde / Yellow-green

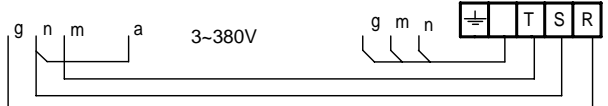
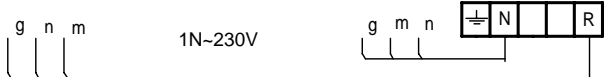
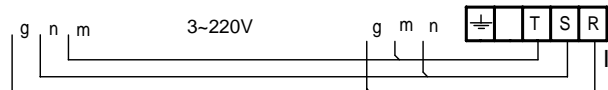

- IG : Interruptor general / Main switch
- IGV : Interruptor de Llenado / Switch electrovalvula water (Mod. EA)
- Ip : Interruptor de seguridad / Security switch (Mod. FE)
- L1 : Lámpara funcionamiento / Operating lamp
- L2 : Lámpara calentamiento / Heating Lamp
- C : Contactor de calentamiento / heating contactor
- R : Resistencia de Calentamiento / Resistance heating
- T : Termostato / thermostat
- Ts : Termostato de seguridad / Hi-limit thermostat
- V : Electrovalvua Agua / Water ElectroValve (mod. EA)

J153003000

-	Esquema teorico FE 605, FTE, CMF 605, BM 710, BM 910		J153003000	
Zk./Nº	Pieza	Cant.	Materiala/Material	Klas. zk/Nº Clas. Gainazal akabera/Tratamiento
Zk./Nº	Aldaketa/Modificaciones		Nork proposatua/Propuesta de	Data/Fecha
-	-	-	-	-
-	-	-	-	-
-	-	-	-	-
-	-	-	-	-
-	-	-	-	-
	Sinadura/Firma	Data/Fecha	 Fagor Industrial, Koop. Elk, Mugatua	
Marratzua/Dibujado	M.Maillo	2011-10-23		
Proiektatua/Proyectado	M.Maillo	2011-10-23		
Egiaztatua/Comprobado	J.Alberdi	2011-10-23		
Eskala/Escala	COOKING			Gainazal perdoia Mecanizado superficial
				Plano Zk./Plano Nº HB-80489
				- Zk. ord. du
	Plano hau ezin daiteke erabili, ez berriztatu, gure baimenik gabe.			- Zk.gaitik ord.

1/2 Modulo BME 605, BME 705, BME 905

Зип Общепит

BM605 3x1,5mm2	Z603041	7A
BM705 3x1,5mm2	X363018	8,7A
BM905 3x1,5mm2	X363018	12A

Resistencia		
1,6 KW	J303001	BME-605
2 KW	R-223005	BME-705
2,8 KW	Z-203601	BME-905

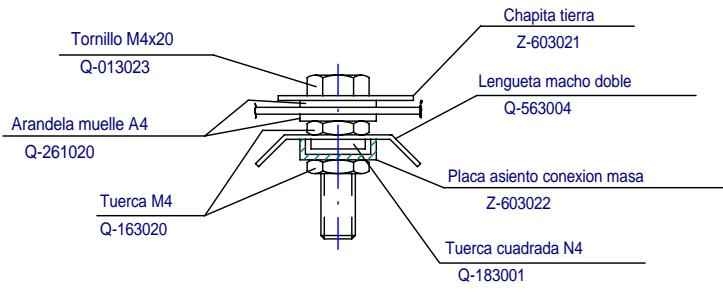
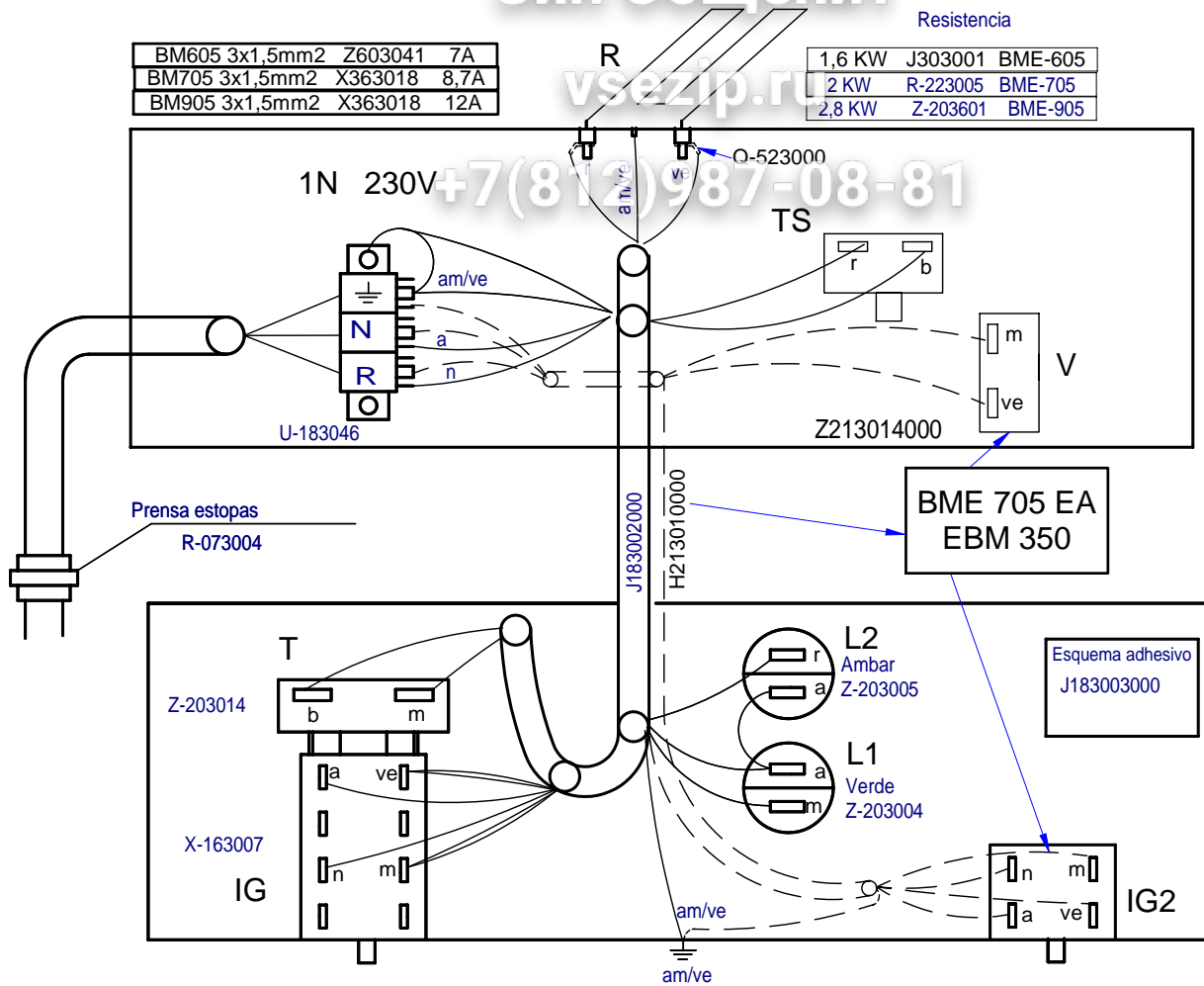

- Plano Montaje BM X05		- J303002000	
Zk./Nº	Pieza	Cant.	Materia/Material
Zk./Nº	Aldaketa/Modificaciones		Nork proposatua/Propuesta de
-	-	-	-
-	-	-	-
-	-	-	-
-	-	-	-
Sinadura/Firma			Data/Fecha
Marratzua/Dibujado	M.Maillo	2009-05-12	 Fagor Industrial, Koop. Elk, Mugatua
Proiektatua/Proyectado	M.Maillo	2009-05-12	
Egiaztatua/Comprobado	<i>J.Alberdi</i>	2009-05-12	
Eskala/Escala	1:1		Plano Zk./Plano Nº
			COOKING
			HB-80531
			- Zk. ord. du
			- Zk.gaitik ord.

Plano hau ezin daiteke erabili, ez berriztatu, gure baimenik gabe.

3 x 2 KW R223005

BME

Зип-Общепит

vsezip.ru

+7(812)987-08-81

BME 710, 910 = 8,7A

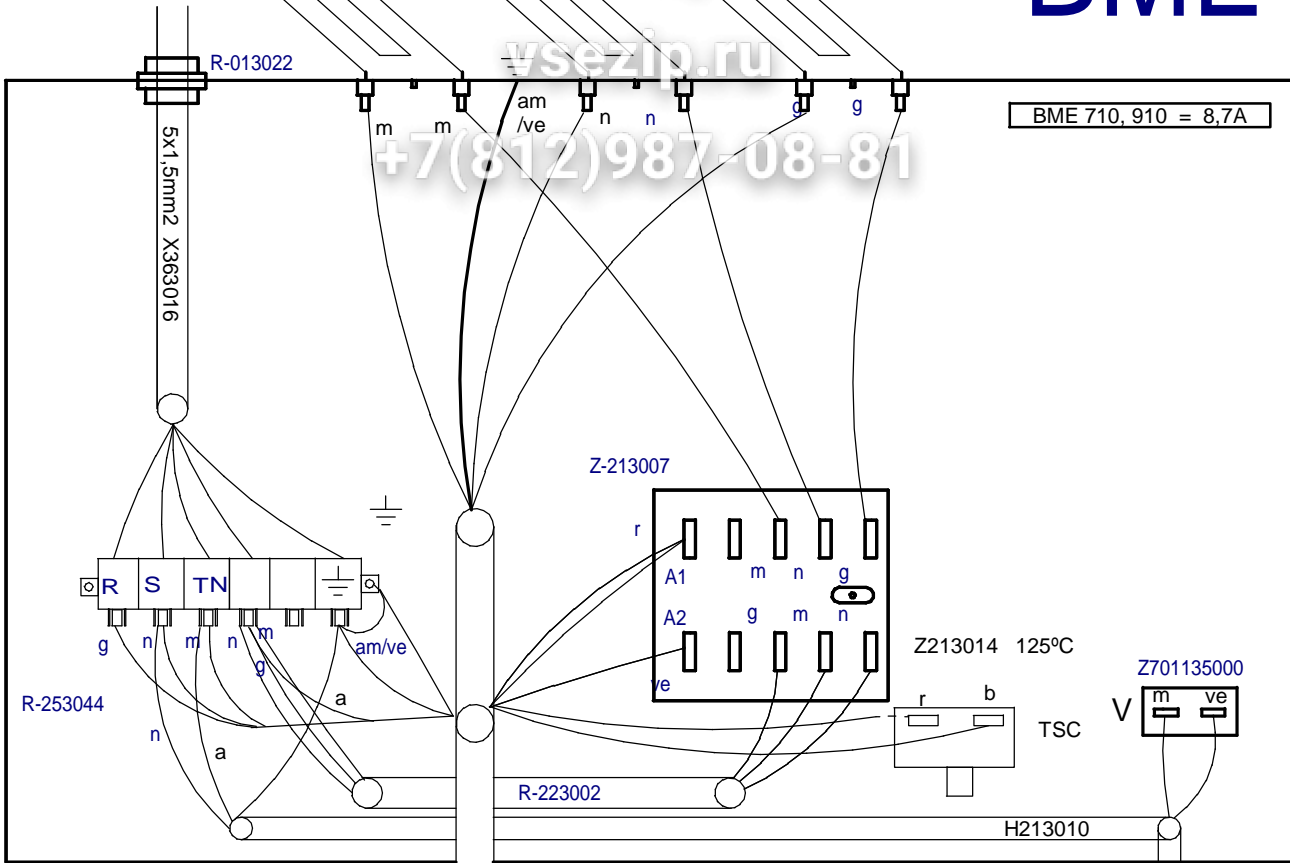

3N~50/60Hz 400V

R223006000

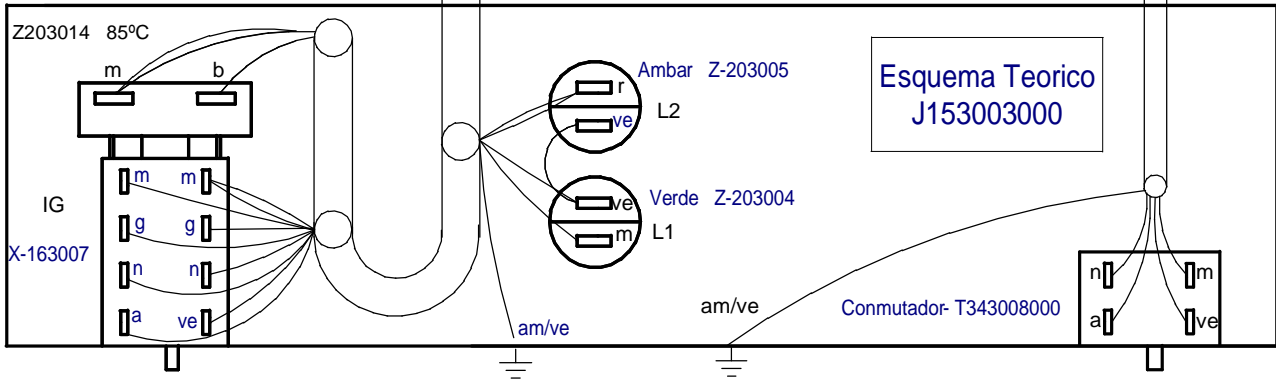

Esquema Teorico
J153003000

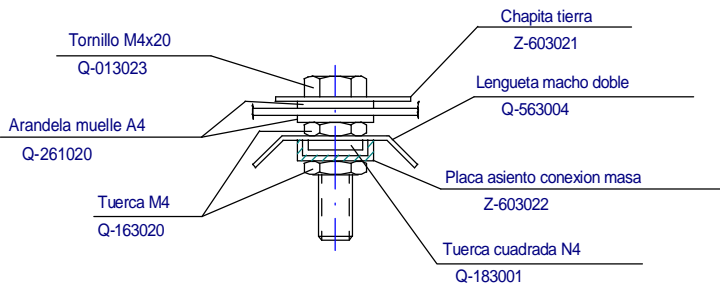

1 Módulo BME-710 c/ entrada de agua

