

Зип Общепит

vsezip.ru

---

DESPIECE TECNICO

---

+7(812)987-08-81

**Fry-tops eléctricos**  
**Electric fry-tops**  
**Fry-tops électriques**  
**Elektro griddle-platten**  
**Fry-tops eletricci**  
**Fry-tops elétricos**

**GAMA SNACK**

**Modelos:**

**FTE6-05**

**FTE6-10**

**FTE/C6-05**

**FTE/C6-10**

***Junio 2009 June***

***Revisado Mayo 2013 May Revised***

**FAGOR** 

---

FAGOR INDUSTRIAL

Зип Общепит

vsezip.ru

+7(812)987-08-81

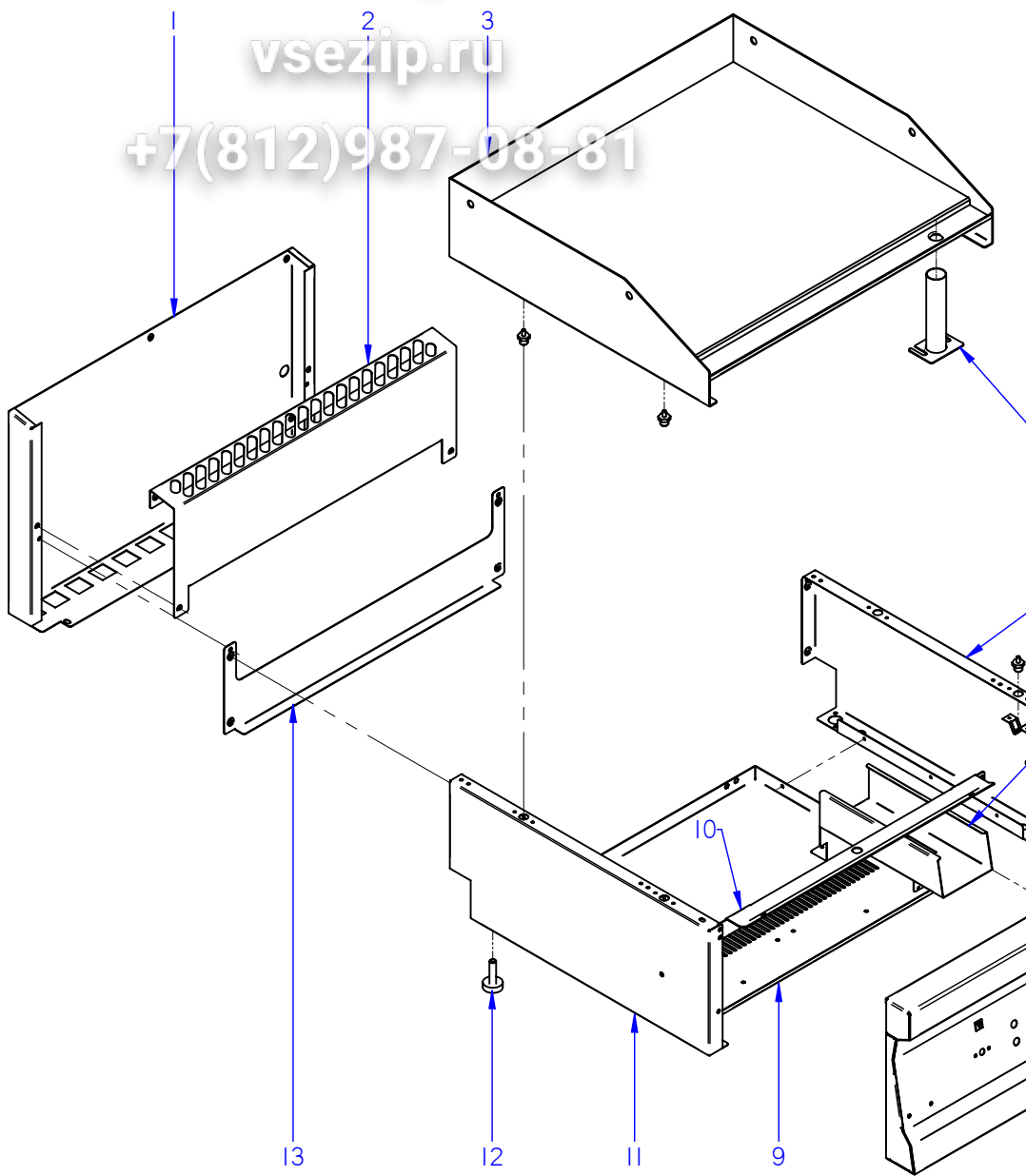

ITEM MARCADO EN COLOR = REPUESTO RECOMENDADO  
COLOURED ITEM = RECOMMENDED SPARE PART

N plano	Firma	Fecha	Aparato	MUEBLE	Lamina	Fagor Industrial S. Coop. <b>FAGOR</b> 
C-2387		2009-06	FRY-TOP FTE6-05 / FTE6-10		1	Oferte

# Зип Общепит

MOD.		FRY-TOP		vsezip.ru		MUEBLE / UNIT			
ITEM	CODIGO	DENOMINACION	TEXTO	FTE6-05	FTE6-10				
1	J142809000	PROTECC. CHIMENEA POST. 400	PROTECTION CHIMEMEY POS.	1	-				
1	J142815000	PROTECTOR CHIMENEA FRYES 400	PROTECTION CHIMEMEY POS.	1	-				
1	J142812000	PROTECC. CHIMENEA POST. 600	PROTECTION CHIMEMEY POS.	-	1				
1	J142816000	PROTECTOR CHIMENEA POST 600	PROTECTION CHIMEMEY POS.	-	1				
	Q419005000	REMACHE 4X8 ALMG3 / ALUMINIO	RIVET 4X8 ALMG3 / ALUMINIUM	2	2				
2	J142810000	PROTECCION CHIMENEA ANT. 400	PROTECTION CHIMENEY ANT	1	-				
2	J142829000	PROTECCION CHIMENEA FREID.	PROTECTION CHIMENEY	1	-				
2	12041345	PROT. CHIME. 400 FRY-TOP SNACK	400 FRY-TOP SNACK PROT.CHI.	1	-				
2	J142813000	PROTECCION CHIMENEA ANT. 600	PROTECTION CHIMENEY ANT	-	1				
2	J142830000	PROTECCION CHIMENEA ANT. 600	PROTECTION CHIMENEY ANT	-	1				
2	12041347	PROT. CHIME. 600 FRY-TOP SNACK	600 FRY-TOP SNACK PROT.CHI.	-	1				
	Q012031000	TORNILLO EXAGONAL M5x10 A304	HEXAGONAL BOLT M5x10 A304	4	4				
	Q302022000	ARANDELA 16x6x1,2 A304	WASHER 16x6x1.2 A304	4	4				
	Q221342000	REMACHE EXAGONAL M5	HEXAGONAL RIVET M5	3	3				
3	J115432000	PLANCHA SNACK E 400 L	PLATE SNACK E 400 L	1	-				
3	12046163	PLANCHA FTE6-05 L COMPL.	PLATE FTE6-05 L COMPL.	1	-				
3	J115434000	PLANCHA SNACK E 400 R	PLATE SNACK E 400 R	1	-				
3	12046230	PLANCHA FTE6-05 R COMPL.	PLATE FTE6-05 R COMPL.	1	-				
3	J115435000	PLANCHA SNACK E 400 L CD	PLATE SNACK E 400 L CD	1	-				
3	12046232	PLANCHA FTE/C6-05 L COMPL.	PLATE FTE/C6-05 L COMPL.	1	-				
3	J115433000	PLANCHA SNACK E 600 L	PLATE SNACK E 600 L	-	1				
3	12046220	PLANCHA FTE6-10 L COMPL.	PLATE FTE6-10 L COMPL.	-	1				
3	J115436000	PLANCHA SNACK E 600 R	PLATE SNACK E 600 R	-	1				
3	12046238	PLANCHA FTE6-10 R COMPL.	PLATE FTE6-10 R COMPL.	-	1				
3	J115440000	PLANCHA SNACK E 600 L+R	PLATE SNACK E 600 L+R	-	1				
3	12046235	PLANCHA FTE6-10 L+ R COMPL.	PLATE FTE6-10 L+ R COMPL.	-	1				
3	J115437000	PLANCHA SNACK E 600 L CD	PLATE SNACK E 600 L CD	-	1				
3	12046243	PLANCHA FTE/C6-10 L COMPL.	PLATE FTE/C6-10 L COMPL.	-	1				
3	J115441000	PLANCHA SNACK E 600 L+R CD	PLATE SNACK E 600 L+R CD	-	1				
3	12046249	PLANCHA FTE/C6-10 L+R COMPL.	PLATE FTE/C6-10 L+R COMPL.	-	1				
3a	12040911	TUBO VACIADO FRY-TOP SNACK	FRY-TOP SNACK DRAIN PIPE	1	1				

# Зип Общепит

MOD.		FRY-TOP		vsezip.ru		MUEBLE / UNIT			
ITEM	CODIGO	DENOMINACION	TEXTO	FTE6-05	FTE6-10				
S/Nº	J105436000	APOYO PLANCHA FRY-TOP	PLATE SUPPORT	4	4				
	Q221342000	REMACHE EXAGONAL M5	HEXAGONAL RIVET M5	6	6				
4	J002802000	PANEL LATERAL DERECHO	RIGHT SIDE PANEL	1	1				
4	J002834000	PANEL LATERAL DERECHO	RIGHT SIDE PANEL	1	1				
	Q221342000	REMACHE EXAGONAL M5	HEXAGONAL RIVET M5	1	1				
	Q419007000	REMACHE TUBULAR C/V D3.2X6	TUBULAR RIVET C/V D3.2X6	8	8				
	X010503000	CIERRE MUELLE	LOCK SPRING	4	4				
	Z442918000	CLIP CIERRE	LOCK SPRING	4	4				
5	J112602000	GUIA RECOGEGRASAS FRY-TOP	GREASE COLLECTION GUIDE	1	1				
	Q419005000	REMACHE 4X8 ALMG3 / ALUMINIO	RIVET 4X8 ALMG3 / ALUMINIUM	4	4				
6	J105432000	ANTERIOR FRY-TOP 400	FRONT FRY-TOP 400	1	-				
6	J105434000	ANTERIOR FRY-TOP 600	FRONT FRY-TOP 600	-	1				
7	J112810000	CAJA RECOGEGRASAS	GREASE COLLECTION TRAY	1	1				
8	J112806000	PORTAMANDOS COMPL. FTE6-05	CONTROL HOLDER FTE6-05	1	-				
8	J112808000	PORTAMANDOS COMPL. FTE6-10	CONTROL HOLDER FTE6-10	-	1				
	U022836000	ESCUDO FAGOR	FAGOR EMBLEM	1	1				
	Q221023000	CLIP SUJECIÓN RÁPIDA Ø5	RAPID CONNECT CLIP Ø5	2	2				
	Q419005000	REMACHE 4x8 ALMG3 / ALUMINIO	RIVET 4X8 ALMG3 / ALUMINIUM	6	6				
	Q012031000	TORNILLO EXAGONAL M5x10 A304	HEXAGONAL BOLT M5x10 A304	2	2				
	Q302022000	ARANDELA 16x6x1,2 A304	WASHER 16x6x1.2 A304	2	2				
9	J002604000	BASE INFERIOR FTE6-05 SNACK	LOWER BASE FTE6-05 SNACK	1	-				
9	J002607000	BASE INFERIOR FTE6-10 SNACK	LOWER BASE FTE6-10 SNACK	-	1				
	Q419005000	REMACHE 4X8 ALMG3 / ALUMINIO	RIVET 4X8 ALMG3 / ALUMINIUM	6	6				
10	J102616000	GUÍA PANEL FRY-TOP 400	GUIDE PANEL FRY-TOP 400	1	-				
10	12002559	GUÍA PANEL OF CONTROLS 400	GUIDE PAN. OF CONTROLS 400	1	-				
13	J102617000	GUÍA PANEL FRY-TOP 600	GUIDE PANEL FRY-TOP 600	-	1				
13	12002749	GUÍA PANEL OF CONTROLS 600	GUIDE PAN. OF CONTROLS 600	-	1				
10	J102617000	GUÍA PANEL FRY-TOP 600	GUIDE PANEL FRY-TOP 600	-	1				
	Q221342000	REMACHE EXAGONAL M5	HEXAGONAL RIVET M5	4	4				
	Q012031000	TORNILLO EXAGONAL M5x10 A304	HEXAGONAL BOLT M5x10 A304	4	4				

# Зип Общепит

MOD.	FRY-TOP	ZCNA vsezip.ru	MUEBLE / UNIT
------	---------	----------------	---------------

ITEM	CODIGO	DENOMINACION	TEXTO	FTE6-05	FTE6-10			
11	J002801000	PANEL LATERAL IZQUIERDO	LEFT SIDE PANEL	1	1			
11	J002833000	PANEL LATERAL IZQUIERDO	LEFT SIDE PANEL	1	1			
	Q221342000	REMACHE EXAGONAL M5	HEXAGONAL RIVET M5	1	1			
	Q419007000	REMACHE TUBULAR C/V D3.2X6	TUBULAR RIVET C/V D3.2X6	8	8			
	X010503000	CIERRE MUELLE	LOCK SPRING	4	4			
	Z442918000	CLIP CIERRE	LOCK SPRING	4	4			
12	Z200107000	PATA REGULABLE	ADJUSTABLE LEG	4	4			
13	J112803000	PANEL POSTERIOR FRY-TOP 400	REAR PANEL FRY-TOP 400	1	-			
13	J112809000	PANEL POSTERIOR FRY-TOP 600	REAR PANEL FRY-TOP 600	-	1			
	Q419005000	REMACHE 4x8 ALMG3 / ALUMINIO	RIVET 4X8 ALMG3 / ALUMINIUM	4	4			

Зип Общепит

vsezip.ru

+7(812)987-08-81

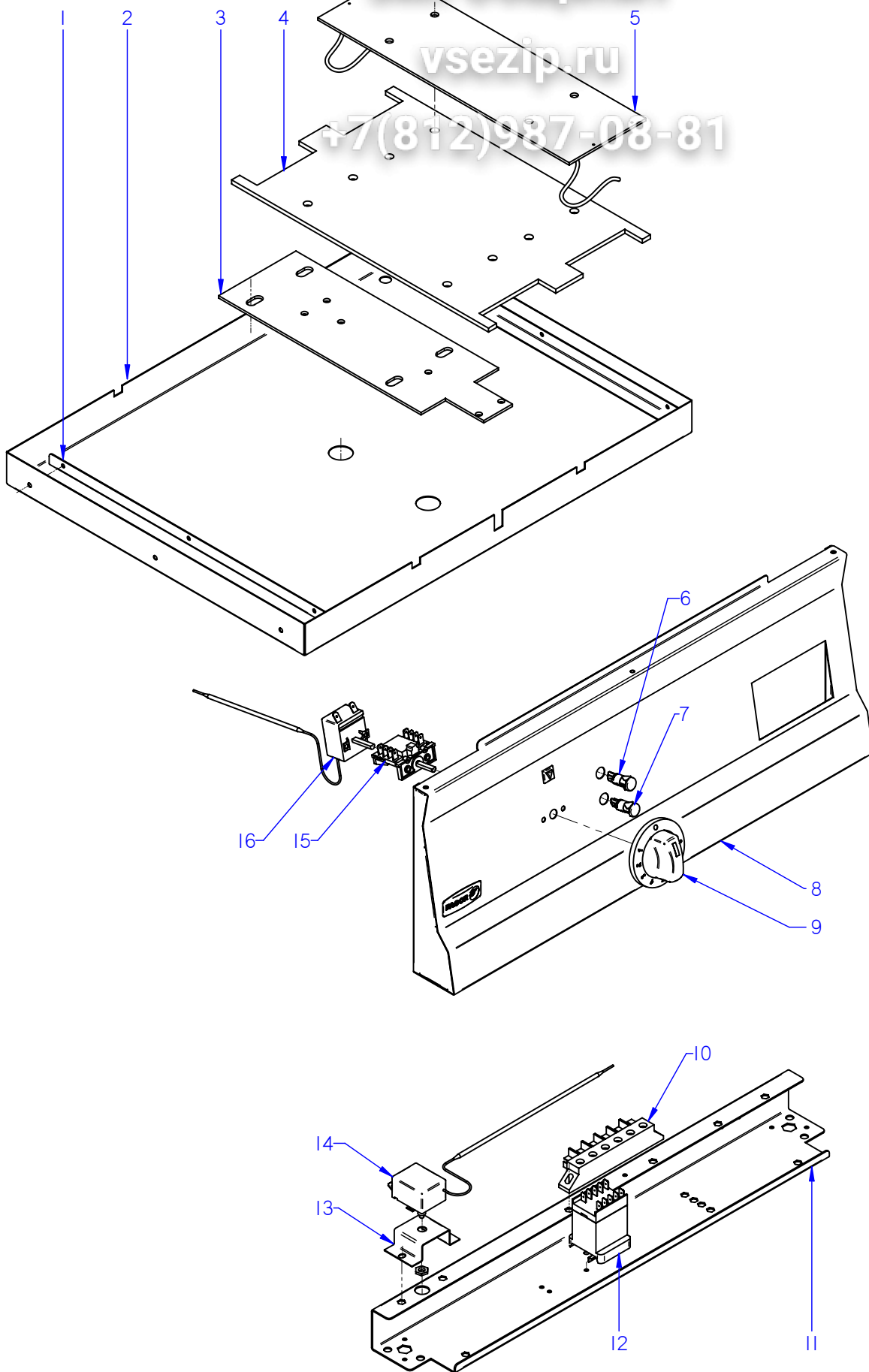

ITEM MARCADO EN COLOR = REPUESTO RECOMENDADO  
COLOURED ITEM = RECOMMENDED SPARE PART

N plano	Firma	Fecha	Aparato	CONJUNTO FUNCIONAL	Lamina	Fagor Industrial S.Coop. <b>FAGOR</b>
C-2388	<i>[Signature]</i>	2009-06	FRY-TOP FTE6-05 / FTE6-10		2	Oñate

# Зип Общепит

MOD.		FRY-TOP		ZCNA		CONJUNTO FUNCIONAL / FUNCTIONAL UNIT			
ITEM	CODIGO	DENOMINACION	TEXTO	FTE6-05	FTE6-10				
1	J112609000	LISTON TOPE BARLAN	STRIP BARLAN	2	2				
	Q419005000	REMACHE 4X8 ALMG3 / ALUMINIO	RIVET 4X8 ALMG3 / ALUMINIUM	6	6				
2	J112608000	CUBIERTA RESISTENC. FTE6-05	RESISTOR COVER FTE6-05	1	-				
2	12046170	CUBIERTA RESISTENC. FTE6-05	RESISTOR COVER FTE6-05	1	-				
2	J112610000	CUBIERTA RESISTENC. FTE6-10	RESISTOR COVER FTE6-10	-	1				
2	12046222	CUBIERTA RESISTENC. FTE6-10	RESISTOR COVER FTE6-10	-	1				
	Q162040000	TUERCA EXAGONAL M6	HEXAGONAL NUT M6	4	4				
	Q302040000	ARANDELA A6	WASHER A6	4	4				
3	J112606000	SOPOR. TOPE BULBO FTE SNACK	BULB SUPPORT FTE SNACK	1	1				
3	12046226	BASE TOPE	BASE TOP	2	2				
4	J115413000	PLETINA RESIST. FTE SNACK	RESIST.PLATE FTE SNACK	1	2				
	Q162040000	TUERCA EXAGONAL M6	HEXAGONAL NUT M6	8	16				
	Q302040000	ARANDELA A6	WASHER A6	8	16				
5	J303001000	RESISTENCIA 1600W 230V	RESISTOR 1600W 230V	3	4				
5	12024620	RESISTENCIA 230V.1500W.SBE-710	RESISTOR 230V.1500W.SBE-710	3	-				
5	12046197	RESISTENCIA 230V 2,10KW 440MM	RESISTOR 30V 2,10KW 440MM	-	3				
6	R693055000	PILOTO VERDE 41227000C7	GREEN PILOT 41227000C7	1	1				
6	12047390	PILOTO VERDE 230V AC 8KW 16MM	GREEN PILOT 230V AC 8KW 16M	1	1				
7	R693056000	PILOTO AMBAR 41227000A4	AMBER PILOT 41227000A4	1	1				
7	12024669	PILOTO AMBAR Ø18	AMBER PILOT Ø18	1	1				
8	J112806000	PORTAMANDOS COMPL. FTE6-05	CONTROL HOLDER FTE6-05	1	-				
8	J112808000	PORTAMANDOS COMPL. FTE6-10	CONTROL HOLDER FTE6-10	-	1				
9	X482101000	BOTON DE MANDO Ø6 G-750Q	CONTROL BUTTON Ø6 G-750Q	1	1				
10	R253044000	REGLETA AUXILIAR FV-122	AUXILIARY TERMINAL STRIP FV-	1	1				
	Q152004000	TORNIL. APLASTADO M5X13 A 304	FLAT HEADED SCREW M5x13 A 3	2	2				
11	J102601000	SOPORTE FRONTAL 400	FRONT SUPPORT 400	1	-				
11	J002605000	SOPORTE FRONTAL 600	FRONT SUPPORT 600	-	1				
12	Z213007000	CONTACTOR 230 V. 50-60 HZ	CONTACTOR 230 V. 50-60 HZ	1	1				
	Z123018000	GUIA CONTACTOR L-55	CONTACTOR GUIDE L-55	1	1				
	Q419005000	REMACHE 4X8 ALMG3 / ALUMINIO	RIVET 4X8 ALMG3 / ALUMINIUM	2	2				





# Зип Общепит

MOD.

FRY-TOP

vsezip.ru

VARIOS / MISCELLANEOUS

ITEM	CODIGO	DENOMINACION	TEXTO	FTE6-05	FTE6-10			
	J116503000	FOLLETO DE INSTR. FTE SNACK	INSTRUC. LEAFLET FTE SNACK	1	1			
	J113001000	ESQUEMA TEORICO FTE6-05	THEOR. DIAGRAM FTE6-05	1				
	J113002000	ESQUEMA TEORICO FTE6-10	THEOR. DIAGRAM FTE6-10		1			
	J113007000	ESQUEMA MONTAJE FTE	ASSEMBLY DIAGRAM FTE	1	1			
	J153006000	CABLEADO CONT. RESISTENCIAS	RESISTORS WIRING CONNECT.		1			
	R223002000	CABLEADO REGLETA CONTACT.	CONTACTOR CONTROL WIRING	1	1			
	J153005000	CABLEADO PORTAMANDOS	CONTROL HOLDER WIRING	1	1			
	R223003000	CABLEADO CONT. RESISTENCIAS	CONNECT. WIRING RESISTORS	1	1			
	12043762	CABLEADO TIERRA ELECTROVAL.	WIRING SOLENOID GROUND	1	1			

ЗЧНА vsezip.ru

REPUESTOS RECOMENDADOS  
RECOMMENDED SPARE PART

MOD. FRY-TOP

+7(812)987-08-81

ITEM	CODIGO	DENOMINACION	TEXTO	FTE6-05	FTE6-10				
5	12024620	RESISTENCIA 230V.1500W.SBE-710	RESISTOR 230V.1500W.SBE-710	3					
5	12046197	RESISTENCIA 230V 2,10KW 440MM	RESISTOR 30V 2,10KW 440MM		3				
6	12047390	PILOTO VERDE 230V AC 8KW 16MM	GREEN PILOT 230V AC 8KW 16MM	1	1				
7	12024669	PILOTO AMBAR Ø18	AMBER PILOT Ø18	1	1				
14	R612103000	TERMOSTATO LIMITADOR	THERMOSTAT LIMITER	1	1				
15	X163007000	CONMUTADOR ACOUPLE TERMOS	THERMOSTAT CONNECT SWITCH	1	1				
16	X153000000	TERMOSTATO 50-310 C	THERMOSTAT 50-310 C	1	1				

FTE6-05

# Зип Общепит

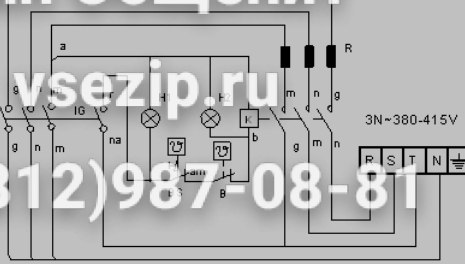

vsezip.ru  
+7(812)987-08-81

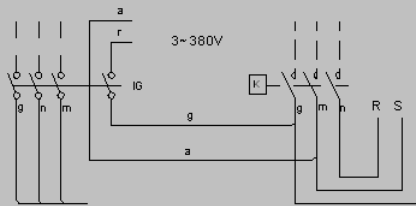
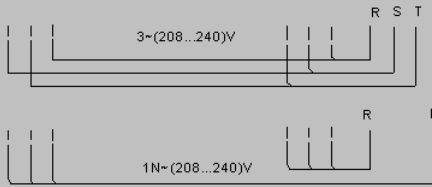

B: Termostato regulable/Adjustable thermostat regulable  
 BS: Termostato de seguridad/Security thermostat  
 IG: Interruptor general/Main switch  
 K: Contactor/Contactor  
 H1: Luz de encendido/Operation lamp  
 H2: Luz de calentamiento/Heating lamp  
 R: Resistencia/Resistance

a = azul-blue  
 am/ve = amarillo/verde - yellow/green  
 b = blanco-white  
 g = gris-grey  
 m = marron-brown  
 n = negro-black  
 na = naranja - orange  
 r = rojo-red

- Theoretical diagram: FTE6-05		-		J113001000	-
Zk./N°	Pieza	Cant.	Material/Material	Klas. zk/N° Clas.	Gainazal akabera/Tra
Zk./N°	Aldaketa/Modificaciones		Nork proposatua/Propuesta de	Data/Fecha	Perdoi orokorr. Tolerancias gene
-	-		-	-	
-	-		-	-	< 5 ± 0.2
-	-		-	-	5 ± 25 ± 0.4
-	-		-	-	25 ± 50 ± 0.6
Sinadura/Firma		Data/Fecha		Gainazal perdo Mecanizado supe	
Marraztua/Dibujado		e.carrascal		2008-10-20	
Proiektatua/Proyectado		e.carrascal		2008-10-20	
Egiaztatua/Comprobado		<i>[Signature]</i>		2008-10-20	
Eskala/Escala		FAGOR  Fagor Industrial, Koop. E.I.k., Mugatua			
-		<b>COOKING</b>			
-		Plano Zk./Plano			
-		<b>HB-80492</b>			
-		Zk. c			
-		Zk. g			

Plano hau ezin daiteke erabili, ez berrizatu, gure baimenik gabe.

# FTE6-10

## Зип Общепит

vsezip.ru  
+7(812)987-08-81

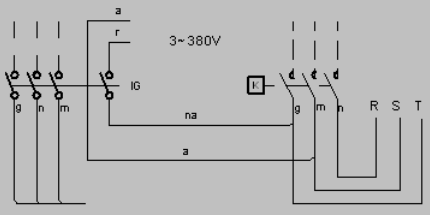
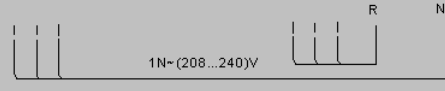
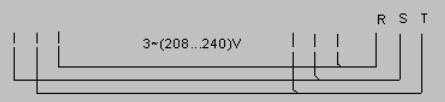
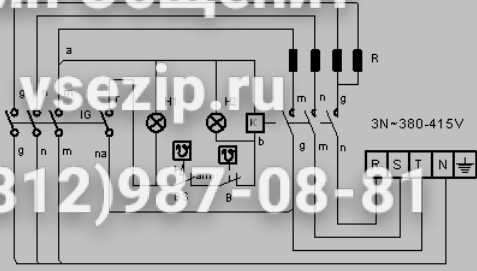

- B: Termostato regulable/Adjustable thermostat regulable  
 BS: Termostato de seguridad/Security thermostat  
 IG: Interruptor general/Main switch  
 K: Contactor/Contactor  
 H1: Luz de encendido/Operation lamp  
 H2: Luz de calentamiento/Heating lamp  
 R: Resistencia/Resistance
- a = azul-blue  
 am/ve = amarillo/verde - yellow/green  
 b = blanco-white  
 g = gris-grey  
 m = marron-brown  
 n = negro-black  
 na = naranja - orange  
 r = rojo-red

- Theoretical diagram: FTE6-10		-		J113002000	-	
Zk./N°	Pieza	Cant.	Material/Material	Klas. zk/N° Clas.	Gainazal akabera/Tra	
Zk./N°	Aldaketa/Modificaciones		Nork proposatua/Propuesta de	Data/Fecha	Perdoi orokorr. Tolerancias gene	
-	-	-	-	-	< 5 ± 0.2	
-	-	-	-	-	5 ± 25 ± 0.4	
-	-	-	-	-	25 ± 50 ± 0.6	
		Sinadura/Firma	Data/Fecha	Gainazal perdo Mecanizado supe		
Marraztua/Dibujado		e.carrascal	2008-10-20	 Fagor Industrial, Koop. E.lk., Mugatua		
Proiektatua/Proyectado		e.carrascal	2008-10-20			
Egiaztatua/Comprobado		<i>[Signature]</i>	2008-10-20			
Eskala/Escala		COOKING			Plano Zk./Plano HB-80493	
-		Plano hau ezin daiteke erabili, ez berrizatu, gure baimenik gabe.			- Zk. c - Zk. g	

FTE 610 4x1,6KW J303001000  
 FTE 605 3x1,6KW J303001000  
 CMF 605 2x1,6KW J303001000  
 FE 605 2x2,75KW J153007000  
 CPE 605 2x3KW J153002000

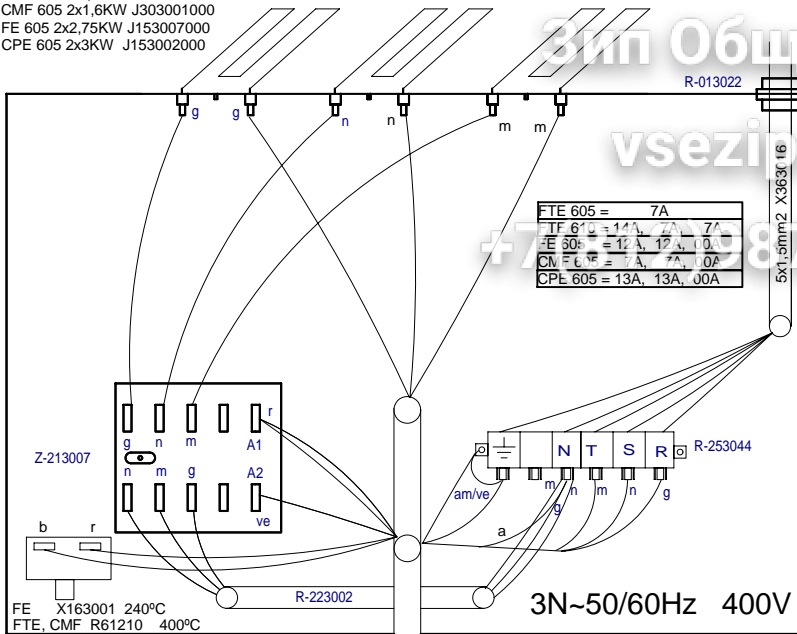

FE 610 x2

FTE 605 FT610,  
 FE 605, CMF 605

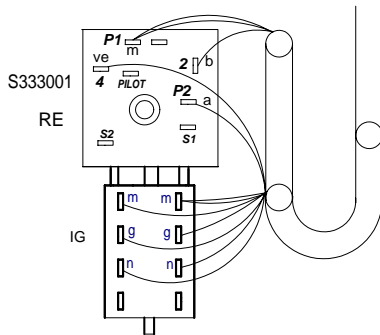
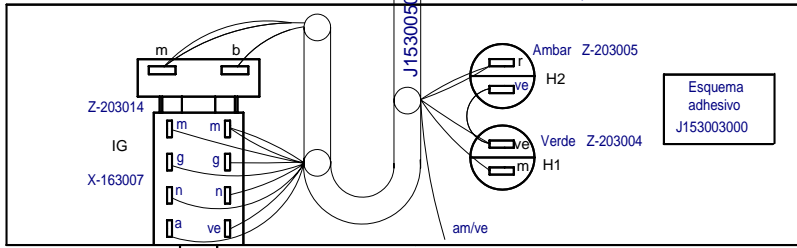

Esquema  
 adhesivo  
 J213001

CPE 605

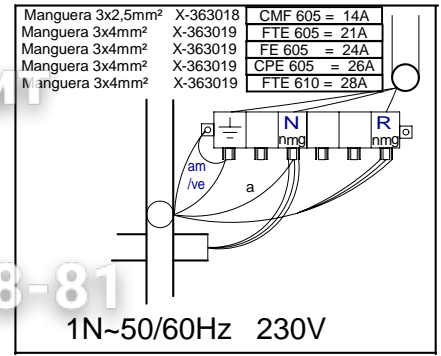

1N~50/60Hz 230V

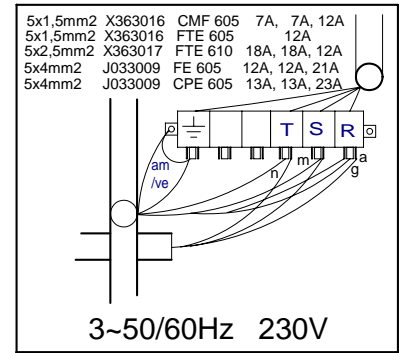
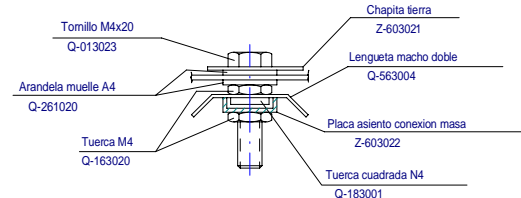

3~50/60Hz 230V

Plano Montaje		
Zk./Nº	Pieza	
Zk./Nº	Aldaketa/Modificaciones	
-	-	-
-	-	-
-	-	-
-	-	-
Sinadura/Firma		Data/Fe
Marratzua/Dibujado		M.Maillo 2009-05
Proiektatua/Proyectado		M.Maillo 2009-05
Egiaztatua/Comprobado		I.Alberdi 2009-05
Eskala/Escala		
Plano hau ezin daiteke er		