

Зип Общепит

vsezip.ru

DESPIECE TECNICO

+7(812)987-08-81

Fry-tops a gas  
Gas fry-tops  
Fry-tops à gaz  
Gas-griddle-platten  
Fry-tops a gas  
Fry-tops a gás

**GAMA 900**

**Modelos:**

**FTG9-05**

**FTG9-10**

**FTG9-05 V**

**FTG9-10 V**

***Marzo 2009 March***

***Revisado Mayo 2014 May Revised***



FAGOR INDUSTRIAL

Зип Общепит

vsezip.ru

+7(812)987-08481

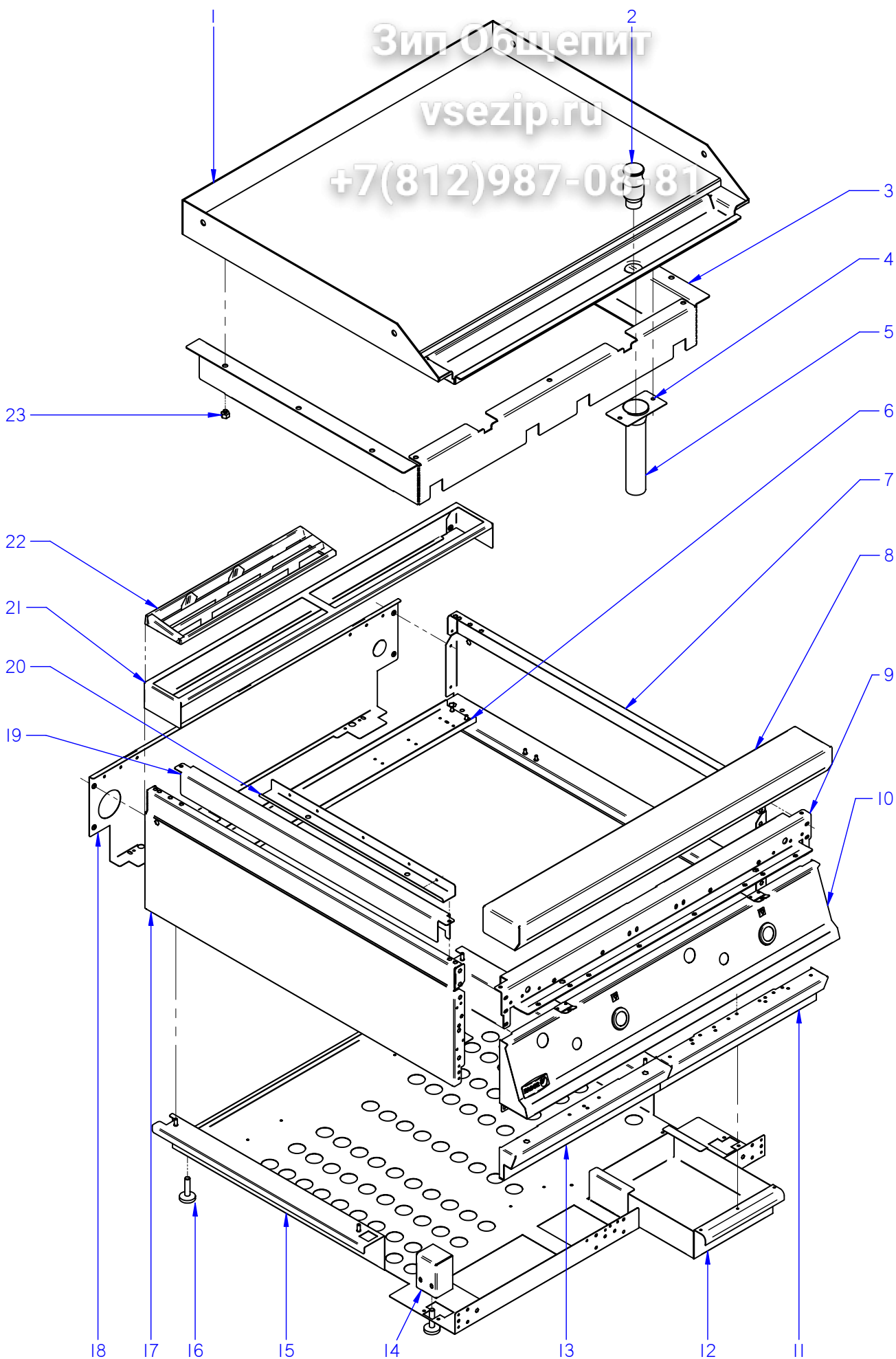

ITEM MARCADO EN COLOR = REPUESTO RECOMENDADO  
COLOURED ITEM = RECOMMENDED SPARE PART

N plano	Firma	Fecha	Aparato	MUEBLE	Lamina	Fagor Industrial S.Coop. <b>FAGOR</b>
C-2285	<i>(Signature)</i>	2009-03	FRY-TOP FTG9-05 / FTG9-10		1	Oñate

MOD.		FRY-TOP		ZONA		MUEBLE			
ITEM	CODIGO	DENOMINACION	TEXTO	FTG9-05	FTG9-10	FTG9-05 V	FTG9-10 V		
1	R045402000	PLANCHA FTG9-05 L EUROSIT	PLATE FTG9-05 L EUROSIT	1	-	-	-		
1	R045405000	PLANCHA FTG9-05 R EUROSIT	PLATE FTG9-05 R EUROSIT	1	-	-	-		
1	R045404000	PLANCHA FTG/C9-05 L EUROSIT	PLATE FTG/C9-05 L EUROSIT	1	-	-	-		
1	R045406000	PLANCHA FTG/C9-05 R EUROSIT	PLATE FTG/C9-05 R EUROSIT	1	-	-	-		
1	R065401000	PLANCHA FTG9-10 L EUROSIT	PLATE FTG9-10 L EUROSIT	-	1	-	-		
1	R065408000	PLANCHA FTG9-10 R EUROSIT	PLATE FTG9-10 R EUROSIT	-	1	-	-		
1	R065406000	PLANCHA FTG9-10 L+R EUROSIT	PLATE FTG9-10 L+R EUROSIT	-	1	-	-		
1	R065405000	PLANCHA FTG/C9-10 L EUROSIT	PLATE FTG/C9-10 L EUROSIT	-	1	-	-		
1	R065409000	PLANCHA FTG/C9-10 R EUROSIT	PLATE FTG/C9-10 R EUROSIT	-	1	-	-		
1	R065407000	PLANCHA FTG/C9-10 L+R EUROS.	PLATE FTG/C9-10 L+R EUROS.	-	1	-	-		
1	R045407000	PLANCHA FTG9-05 L VALVULA	PLATE FTG9-05 L VALVE	-	-	1	-		
1	R045408000	PLANCHA FTG9-05 R VALVULA	PLATE FTG9-05 R VALVE	-	-	1	-		
1	R065410000	PLANCHA FTG9-10 L VALVULA	PLATE FT9-10 L VALVE	-	-	-	1		
1	R065412000	PLANCHA FTG9-10 R VALVULA	PLATE FTG9-10 R VALVE	-	-	-	1		
1	R065411000	PLANCHA FTG-910 L+R VALVULA	PLATE FTG-910 L+R VALVE	-	-	-	1		
2	R045415000	TAPON DESAGÜE CR-DURO	DRAINAGE CAP CHROME PLATE	1	1	-	-		
3	R042610000	CAJA COMBUSTIÓN 1/2 M	COMBUSTION BOX 1/2 M	1	-	1	-		
3	R162638000	PROTECCIÓN LATERAL	LATERAL PROTECTION	1	1	1	1		
3	R042608000	LISTON FRONTAL FTG9-05	RIBBON FRONT FTG9-05	1	-	1	-		
3	R162645000	CAJA COMBUSTIÓN 1 M	COMBUSTION BOX 1 M	-	1	-	1		
3	R162643000	LISTON FRONTAL FTG9-10	RIBBON FRONT FTG9-10	-	1	-	1		
	Q012042000	TORNILLO EXAGONAL M6X15 A304	HEXAGONAL BOLT M6X15 A.304	2	3	2	3		
4	R152607000	SOPORTE TUBO DESAGÜE	DRAINAGE PIPE SUPPORT	1	1	1	1		
	Q302022000	ARANDELA 16X6X1.2 A.304	WASHER 16X6X1.2 A.304	2	2	2	2		
	Q162040000	TUERCA EXAGONAL M6	HEXAGONAL NUT M6	2	2	2	2		
5	R155010000	TUBO DESAGÜE FRY-TOP G-900	DRAINAGE PIPE FRY-TOP G900	1	1	1	1		
6	R152622000	BASE SOP. QUEMADOR FTG9-05	FTG9-05 BURNER BRACKET BAS	1	-	1	-		
6	R162642000	BASE SOP. QUEMADOR FTG9-10	FTG9-10 BURNER BRACKET BAS	-	1	-	1		
	Q262030000	ARANDELA GROW. A5 A.304	WASHER GROW. A6 A.304	4	4	4	4		
	Q162040000	TUERCA EXAGONAL M6	HEXAGONAL NUT M5	4	4	4	4		

# Зип Общепит

MOD.		FRY-TOP		MUEBLE			
ITEM	CODIGO	DENOMINACION	TEXTO	FTG9-05	FTG9-10	FTG9-05 V	FTG9-10 V
7	R062810000	PANEL LATERAL DERECHO G9-00	RIGHT SIDE PANEL G900	1	1	1	1
	Q221342000	REMACHE EXAGONAL M5	HEXAGONAL RIVET M5	7	7	7	7
	Q162030000	TUERCA EXAGONAL M5	HEXAGONAL NUT M5	2	2	2	2
	Q221345000	REMACHE EXAGONAL M10	HEXAGONAL RIVET M10	2	2	2	2
	Q419005000	REMACHE 4X8 ALMG3 / ALUMINIO	RIVET 4X8 ALMG3 / ALUMINIUM	2	2	2	2
8	R045416000	ANTERIOR DE MESA 1/2 M	FRONT BENCH 1/2 M	1	-	1	-
8	S105402000	ANTERIOR DE MESA 1 M	FRONT BENCH 1 M	-	1	-	1
	Q152004000	TORN. APLASTADO M5x13 A304	FLAT HEADED SCREW M5x13	2	2	2	2
9	X162680000	ESCUADRA AMARRE ANTER.1/2 M	FRONT FASTENING BRACKET	1	-	1	-
9	U022605000	ESCUADRA AMARRE ANTERI.1M	FRONT FASTENING BRACKET	-	1	-	1
	Q221342000	REMACHE EXAGONAL M5	HEXAGONAL RIVET M5	3	4	3	4
	Q012032000	TORNILLO EXAGONAL M5X15 A304	HEXAGONAL BOLT M5X15 A304	6	6	6	6
10	R042827000	PORTAMANDOS FTG9-05 EUR	CONTROL HOLDER FTG9-05 E	1	-	-	-
10	R062822000	PORTAMANDOS FTG9-10 EUR	CONTROL HOLDER FTG9-10 E	-	1	-	-
10	R042826000	PORTAMANDOS FTG9-05 V	CONTROL HOLDER FTG9-05 V	-	-	1	-
10	R062824000	PORTAMANDOS FTG9-10 V	CONTROL HOLDER FTG9-10 V	-	-	-	1
	U022836000	ESCUDO FAGOR	FAGOR EMBLEM G700	1	1	1	1
	Q221023000	CLIP SUJECIÓN RÁPIDA Ø5	RAPID CONNECT CLIP Ø5	2	2	2	2
11	H012821000	ASA BANDEJA IZQUIER.-DERECHA	SKIRTING ASA	1	1	1	1
12	R152608000	CAJA RECOGEGRASAS	GREASE COLLECTION TRAY	1	1	1	1
	Q419005000	REMACHE 4x8 ALMG3 / ALUMINIO	RIVET 4X8 ALMG3 / ALUMINIUM	3	3	3	3
13	R062805000	ZOCALO INFERIOR FRY-TOP	SKIRTING ASA	-	1	-	1
	Q012042000	TORNILLO EXAGONAL M6x15	HEXAGONAL BOLT M6X15	-	2	-	2
	Q302022000	ARANDELA 16x6x1,2 A304	WASHER 16X6X1.2 A.304	-	2	-	2
14	H012805000	ESCUADRA AMARRE PATA	LEG FASTENING BRACKET	2	2	2	2
	X010503000	CIERRE MUELLE	LOCK SPRING	2	2	2	2
	Q419007000	REMACHE TUBULAR C/V Ø3,2x6	TUBULAR RIVET C/V Ø3.2X6	4	4	4	4
	Q162030000	TUERCA EXAGONAL M5	HEXAGONAL NUT M5	4	4	4	4
	Q262030000	ARANDELA GROW. A5 A304	WASHER GROW. A5 A.304	4	4	4	4

# Зип Общепит

MOD.		FRY-TOP		ZONA		MUEBLE	
ITEM	CODIGO	DENOMINACION	TEXTO	FTG9-05	FTG9-10	FTG9-05 V	FTG9-10 V
15	R152820000	BASE INFERIOR FTG9-05 COMPL.	LOWER BASE FTG9-05	1	-	1	-
15	R162821000	BASE INFERIOR FTG9-10 COMPL.	LOWER BASE FTG9-10	-	1	-	1
	Q221345000	REMACHE EXAGONAL M10	HEXAGONAL RIVET M10	2	2	2	2
	Q221343000	REMACHE EXAGONAL M6	HEXAGONAL RIVET M6	-	2	-	2
16	Z200107000	PATA REGULABLE	ADJUSTABLE LEG	4	4	4	4
	Q221345000	REMACHE EXAGONAL M10	HEXAGONAL RIVET M10	4	4	4	4
17	R062811000	PANEL LATERA IZQUIERDO G-900	LEFT SIDE PANEL G-900	1	1	1	1
	Q221342000	REMACHE EXAGONAL M5	HEXAGONAL RIVET M5	7	7	7	7
	Q162030000	TUERCA EXAGONAL M5	HEXAGONAL NUT M5	2	2	2	2
	Q221345000	REMACHE EXAGONAL M10	HEXAGONAL RIVET M10	2	2	2	2
	Q419005000	REMACHE 4X8 ALMG3 / ALUMINIO	RIVET 4X8 ALMG3 / ALUMINIUM	2	2	2	2
18	H012824000	PANEL POSTERIOR 1/2M	REAR PANEL 1/2M	1	-	1	-
18	H022809000	PANEL POSTERIOR 1M	REAR PANEL 1M	-	1	-	1
	Q419005000	REMACHE 4x8 ALMG3 / ALUMINIO	RIVET 4X8 ALMG3 / ALUMINIUM	4	4	4	4
	X010503000	CIERRE MUELLE	LOCK SPRING	2	2	2	2
19	R152807000	LATERAL DE MESA	BENCH SIDE	2	2	2	2
	Q012032000	TORNILLO EXAGONAL M5X15 A304	HEXAGONAL BOLT M5X15 A304	6	6	6	6
20	R152601000	TIRANTE LATERAL	SIDE TIE ROD	2	2	2	2
	Q419005000	REMACHE 4X8 ALMG3 / ALUMINIO	RIVET 4X8 ALMG3 / ALUMINIUM	6	6	6	6
21	R205438000	SOPORTE EMBELLECEDOR 1/2M	1/2M TRIM SUPPORT	1	-	1	-
21	R205439000	SOPORTE EMBELLECEDOR 1M	TRIM SUPPORT 1M	-	1	-	1
	Q419005000	REMACHE 4X8 ALMG3 / ALUMINIO	RIVET 4X8 ALMG3 / ALUMINIUM	2	2	2	2
22	R205425000	EMBELLECEDOR ESMALTE	ENAMEL TRIM	1	2	1	2
23	R615412000	APOYO LATERAL	SIDE SUPPORT	6	6	6	6

Зип Общепит

vsezip.ru

+7(812)987-08-81

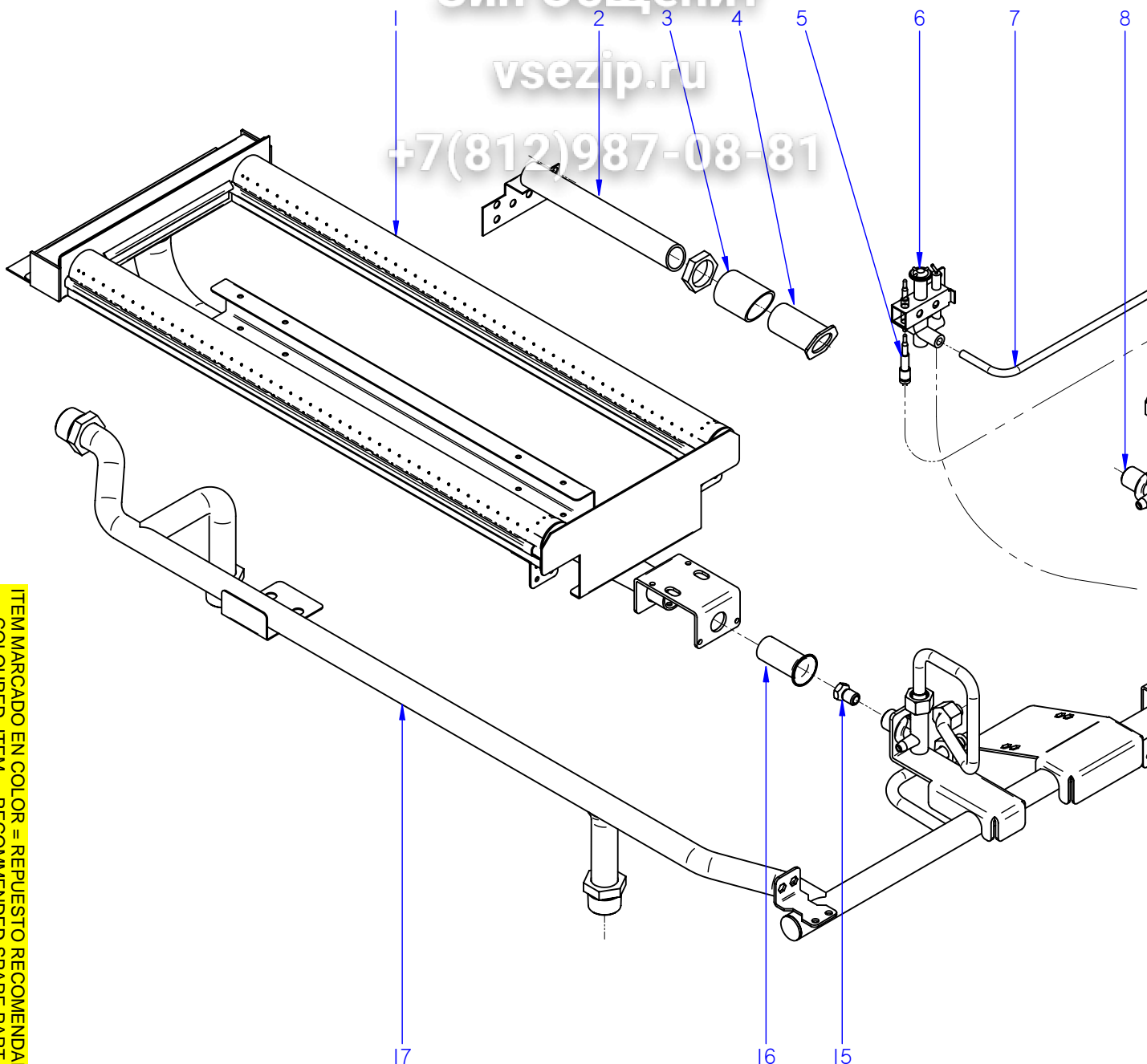

ITEM MARCADO EN COLOR = REPUESTO RECOMENDADO  
COLOURED ITEM = RECOMMENDED SPARE PART

N plano	C-2286
Firma	
Fecha	2009-03
Aparato	FRY-TOP FTG9-05 / FTG9-10
PARTE FUNCIONAL	
Lamina	2
Fagor Industrial S. Coop. Ortze	

# Зип Общепит

MOD.		FRY-TOP		vsezip.ru		CONJUNTO FUNCIONAL			
ITEM	CODIGO	DENOMINACION	TEXTO	FTG9-05	FTG9-10				
1	R635700000	QUEMADOR COMPLETO FTG9-00	COMPLETE BURNER FTG-710	1	2				
	Q012031000	TORNILLO EXAGONAL M5x10 A304	HEXAGONAL BOLT M5X10 A304	2	4				
	Q302022000	ARANDELA 16x6x1,2 A304	HEXAGONAL BOLT M5X10 A304	2	4				
2	R045014000	TUBO ENCENDIDO COMPLETO	COMPLETE IGNITION PIPE	1	2				
3	R065025000	DISTANCIADOR	SPACER	1	2				
	Q221324000	TUERCA 3/4 GAS	NUT 3/4 GAS	1	2				
4	R042822000	EMBELLECED. TUBO ENCENDIDO	IGNITION PIPE TRIM	1	2				
5	U562130000	TERMOPAR L=850	THERMOCOUPLE L=850	1	2				
6	U322118000	PILOTO COMPLETO 100.062	COMPLETE PILOT LIGHT 100.062	1	2				
	U442137000	INYECTOR Ø 0.4 GN	INJECTOR Ø 0.4 GN.	1	2				
	Q012031000	TORNILLO EXAGONAL M5X10 A.304	HEXAGONAL BOLT M5X10 A.304	2	4				
7	R065042000	TUBO PILOTO EUROSIT	PILOT PIPE EUROSIT	1	2				
7	12010623	TUBO PILOTO EUROSIT REMOD.	PILOT PIPE EUROSIT	1	2				
8	U915014000	PORTATOVERAS HORNO	NOZZLE HOLDER	1	2				
	Q223019000	TUERCA 3/8 GAS LATÓN	NUT 3/8 GAS BRASS	1	2				
	Q301323000	ARANDELA Ø25X17X6	WASHER Ø25X17X6	1	2				
	Q306062000	ARANDELA Ø13,9X10,33X1,5	WASHER Ø13,9X10,33X1,5	1	2				
	Q153002000	TORNILLO TAPON	CAP BOLT	1	2				
9	R065031000	CONDUCC. QUEMADOR EUROSIT	BURNER PIPE EUROSIT	1	2				
	Q306062000	ARANDELA Ø13,9X10,33x1,5	WASHER Ø13.9X10.33x1.5	2	4				
10	R155068000	MANGUITO 3/8"	HOSE 3/8"	2	4				
11	R152102000	VALVULA 630 EUR 630.343 META	VALVE 630 EUR 630.343 META	1	2				
	T982102000	TAPON 3/8 972.061	CAP 3/8 972.061	2	4				
	Q011338000	TORNILLO EXAGONAL M5X60	HEXAGONAL SCREW M5X60	2	4				
12	R062102000	EJE BOTON MANDO EUROSIT META	CTRL. BUTTN. SHAFT EUROSIT M	1	2				
	Q012031000	TORNILLO EXAGONAL M5X10 A304	HEXAGONAL BOLT M5X10 A304	1	2				
13	R042102000	BOTON DE MANDO FTG EUR	CONTROL BUTTON FTG EUR	1	2				
14	S113034000	PIEZOELECTRICO	PIEZOELECTRIC	1	2				
14	12043897	PIEZOELECTRICO COMPLETO	COMPLETE PIEZOELECTRIC	1	2				
S/Nº	12043907	ANILLO ADAPTADOR	ADAPTER RING	1	1				
S/Nº	X022131000	BUJIA	SPARK PLUG	1	2				





Зип Общепит

vsezip.ru

+7(812)987-08-81

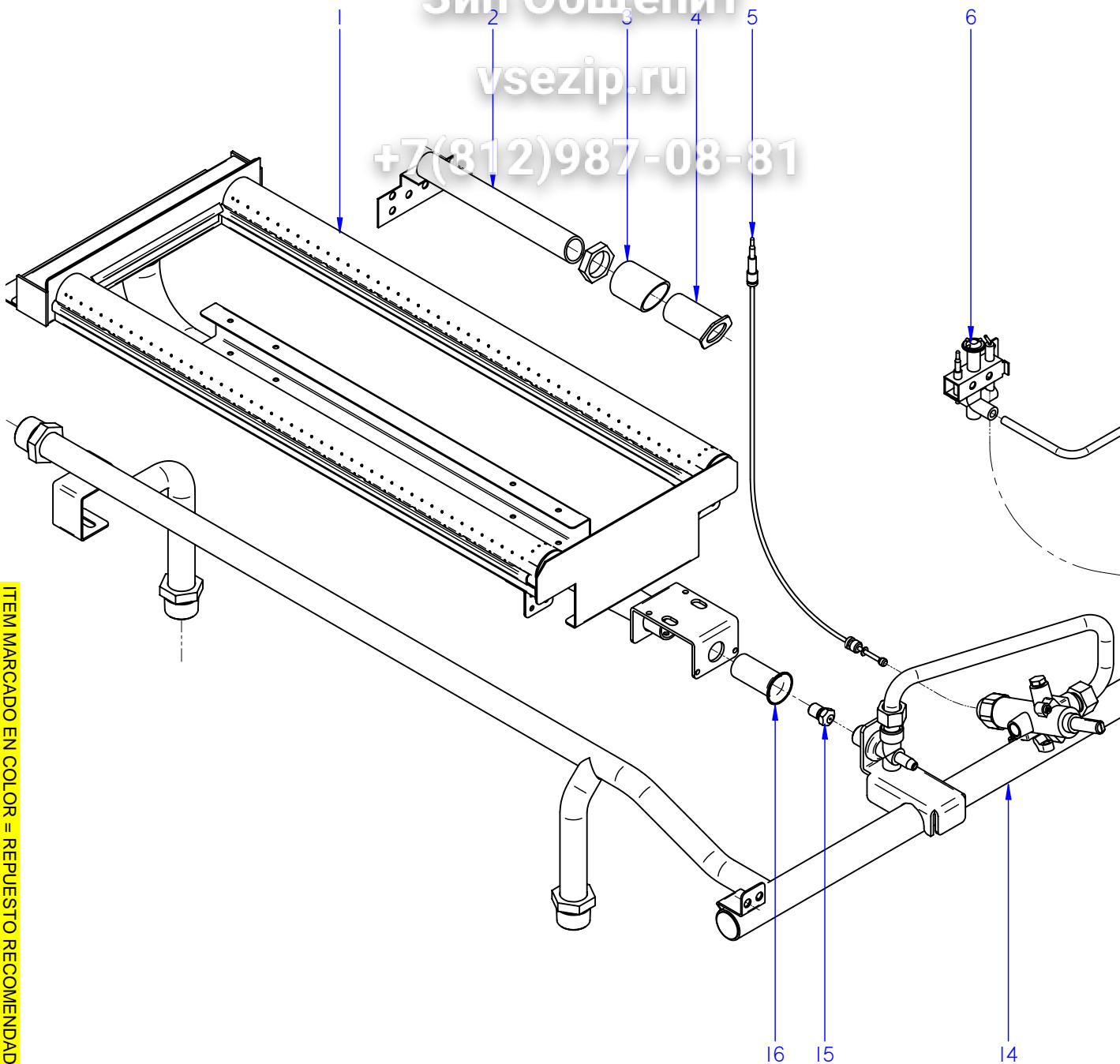

N plano  
C-2287  
Firma  
Fecha  
2009-03  
Aparato  
FRY-TOP FTG9-05 V / FTG9-10 V  
CONJUNTO FUNCIONAL

Lamina  
3

Fagor Industrial S. Coop. **FAGOR**  
Ortfe

ITEM MARCADO EN COLOR = REPUESTO RECOMENDADO  
COLOURED ITEM = RECOMMENDED SPARE PART

# Зип Общепит

MOD.		FRY-TOP		vsezip.ru		CONJUNTO FUNCIONAL			
ITEM	CODIGO	DENOMINACION	TEXTO	FTG9-05 V	FTG9-10 V				
1	R635700000	QUEMADOR COMPLETO FTG9-00	COMPLETE BURNER FTG-710	1	2				
	Q012031000	TORNILLO EXAGONAL M5x10 A304	HEXAGONAL BOLT M5X10 A304	2	4				
	Q302022000	ARANDELA 16x6x1,2 A304	HEXAGONAL BOLT M5X10 A304	1	4				
2	R045014000	TUBO ENCENDIDO COMPLETO	COMPLETE IGNITION PIPE	1	2				
3	R065025000	DISTANCIADOR	SPACER	1	2				
	Q221324000	TUERCA 3/4 GAS	NUT 3/4 GAS	1	2				
4	R042822000	EMBELLECED. TUBO ENCENDIDO	IGNITION PIPE TRIM	1	2				
5	U222130000	TERMOPAR L=600	THERMOCOUPLE L=600	1	2				
6	U322118000	PILOTO COMPLETO 100.062	COMPLETE PILOT LIGHT 100.062	1	2				
	U442137000	INYECTOR Ø 0.4 GN	INJECTOR Ø 0.4 GN.	1	2				
	Q012031000	TORNILLO EXAGONAL M5X10 A.304	HEXAGONAL BOLT M5X10 A.304	2	4				
7	R065043000	TUBO PILOTO	PILOT PIPE	1	2				
7	12010625	TUBO PILOTO VALVULA REMODEL	PILOT PIPE	1	2				
	X205028000	BICONO Ø6	BICONE Ø6	—	2				
8	U265033000	PORTATOVERAS Ø10	NOZZLE HOLDER Ø10	1	2				
	Q223019000	TUERCA 3/8 GAS LATÓN	NUT 3/8 GAS BRASS	1	2				
	Q301323000	ARANDELA Ø25X17X6	WASHER Ø25X17X6	1	2				
	Q306062000	ARANDELA Ø13,9X10,33X1,5	WASHER Ø13,9X10,33X1,5	1	2				
	Q153002000	TORNILLO TAPON	CAP BOLT	1	2				
9	R902102000	GRIFO 18700 BY-PASS 0,9	TAP 18700 BY-PASS 0.9	1	2				
	Q307034000	JUNTA ESTANQUEIDAD	SEAL	1	2				
	Q012033000	TORNILLO EXAGONAL M5X20 A304	HEXAGONAL BOLT M5X20 A304	1	2				
10	R065035000	CONDUCCION QUEMADOR V FTG	BURNER PIPE V FTG	1	2				
	Q306062000	ARANDELA Ø13,9X10,33x1,5	WASHER Ø13.9X10.33x1.5	2	4				
11	U022117000	BOTON DE MANDO Ø8	CONTROL BUTTON Ø8	1	2				
12	U912104000	BRIDA AMARRE GRIFO 1/2"	TAP FASTENING FLANGE 1/2"	1	2				
	Q122032000	TORNILLO ALLEN M.5x15	ALLEN HEAD SCREW M.5x15	2	4				
13	S113034000	PIEZOELECTRICO	PIEZOELECTRIC	1	2				
13	12043897	PIEZOELECTRICO COMPLETO	COMPLETE PIEZOELECTRIC	1	2				
S/Nº	12043907	ANILLO ADAPTADOR	ADAPTER RING	1	1				
S/Nº	X022131000	BUJIA	SPARK PLUG	1	2				





# Зип Общепит

vsezip.ru

+7(812)987-08-81

ITEM	CODIGO	DENOMINACION		FTG9-05	FTG9-10	FTG/C9-05	FTG/C9-10
MOD. <span style="border: 1px solid black; padding: 2px;">FRY-TOP</span>				PIEZAS ESPECIFICAS PARA LOS DISTINTOS			
		<b><u>BUTANO PROPANO</u></b>	<b><u>BUTANE PROPANE</u></b>				
15	9105100000	TOBERA Ø 1,50 B.P.	NOZZLE Ø 1,50 B.P.	1	2	-	-
15	U052401000	TOBERA Ø 1,45 B.P	NOZZLE Ø 1,45 B.P	-	-	1	2
S/Nº	U136501000	INDICADOR BUTANO-PROPANO	INDICATOR BUTANE-PROPANE	1	1	1	1
		<b><u>GAS NATURAL</u></b>	<b><u>NATURAL GAS</u></b>				
6	U442137000	INYECTOR Ø 0.4 GN.	INJECTOR Ø 0.4 GN.	1	2	1	2
15	1011600000	TOBERA Ø 2,25 G.N,	NOZZLE Ø 2,25 G.N.	-	-	-	-
15	U262400000	TOBERA Ø 2,15 G.N.	NOZZLE Ø 2,15 G.N.	-	-	1	2
S/Nº	U134402000	INDICADOR GAS-NATURAL	INDICATOR GAS-NATURAL	-	-	1	1
		<b><u>GAS VILLA</u></b>	<b><u>VILLA GAS</u></b>				
5	U442137000	INYECTOR Ø 0.4 GN	INJECTOR Ø 0.4 GN.	-	-	-	-
13	X102403000	TOBERA Ø 4,58 G.V.	NOZZLE Ø 4,58 G.V.	-	-	-	-
S/Nº	U134310000	INDICADOR GAS-VILLA	INDICATOR GAS-VILLA	-	-	-	-



