

Зип Общепит  
vsezip.ru  
+7(812)987-08-81

# ***DESPIECES ARMARIOS***

## ***GASTRO-1600***



*Rev.: Oct-2012*

Nº	DESCRIPCIÓN	MODELOS														
		AFP-602	AFP-600	AFP-700	AF-1600-1	AF-1600-P	AF-1600-2	AF-1604-C	AFN-1602	AFN-1603	AFN-1604	AFP-1602/2	AFP-1603/2	AF-1602-MIX	AEP-1602	
1	6007050017	PATA REGULABLE ARM.GASTRO	4	4	4	4	4	4	4	4	4	4	6	6	6	4
3	6021350113	SONDA NTC 2.5 MTS	1	1	1	2	2	3	3	2	2	2	2	3	1	1
4	A109010824	CABEZA AF-1600 MIXTO											1	1	1	
4	A109010823	CABEZA AF-1600 DPTO				1	1	1	1							
4	A109010816	CABEZA AFP-1600				1	1	1	1	1	1					1
5	6021130041	MICROR.COMMUT.E3111CA	2	2	2	2	2	2	2	2	2	2	2	2	2	2
6	6023010553	PEG.FAGOR GAMA CONCEPT	1	1	1						1	1	1	2	2	2
6	6023010554	PEG. FAGOR GAMA CONCEPT DPTO				1	1	1	1							
7	6021130065	INTERRUPTOR BIP. O/I NEGRO/ROJO	1	1	1	2	2	2	2	2	1	1	1	2	2	2
8	6021130066	INTERRUPTOR UNIPOL. NEGRO/ROJO														1
9	A177090018	CONJ.TERM. REF. 220v 50Hz	1	1	1	1	1	1	1	1			2	2	1	1
10	A109250012	SOP.CARC.VENTIL.AFP-1400 COMP.	1	1	1	1	1	1	1	1	1	1				1
11	6029010014	EV.B14T2R426A6S DPTO.PESC PIN.				1	1									
11	6029010148	2XBAT.4T6R350A4S PINT.AFP1400	1	1	1	1	1	1	1	1						1
11	6029010149	2XBAT.4T6R350A6S PINT.AFN1400									1	1	1			
11	6029010146	BAT.6T4R300A4S PINTADO.ARMARIO											2	2	1	
11	6029010174	BAT.6T4R 300A 6S. 2 CIRCUITOS														1
11	6029010153	BAT.6T4R 300A 6S.PINT.ARMARIOS						1	1							
12	A109250011	SUJ.VENT.AFP-1400,1600 COMPACT	1	1	1	1	1	1	1	1	1	1				1
12	A109250009	SUJ.VENT.AFP-700,800 COMPACTO						1	1				2	2	2	
13	6021050067	VENT.EVAP.10W S/ARO S/PATAS	1	1	1	1	1	1	1	1	1	1				1
13	6021050066	VENTIL.EVAPOR.5W S/ARO S/PATAS						1	1				2	2	2	
14	6027130004	REJILLA VENT.D.246 PINTADA						1	1				2	2	2	
14	6027130005	REJILLA VENT.D297 PINTADA	1	1	1	1	1	1	1	1	1	1				1
15	A109250014	CUBRER.2BAT4T6R350A 6S AFN1400	2	2	2	2	2	2	2	2	2	2				2
16	6003010033	DESAGÜE 1/2 PULG. CUELLO CORTO				1	1									
17	6003010175	CODO PVC MIXTO 90º 20x1/2				1	1									
18	6021010020	COMPR.J2212GK 220V50Hz ASPERA									1	1	1			
18	6021010007	COMPRES.FR-8.5-G R134A											2	2	1	
18	6021010154	COMP.NEK6210Z EMBRACO	1	1	1	1	1	1	1	1						1
19	6029020016	CONDENSADOR DOBLE 9X3 DCHA-TEC									1	1	1			
19	6029020002	CONDENSADOR 9X2											2	2	1	
19	6029020003	CONDENSADOR 9x3 FAGC0021	1	1	1	1	1	1	1	1						1
20	6021050002	VENTILADOR 10W PATA PALA 220V	1	1	1	1	1	1	2	2	2	2	2	2	1	1
22	6021290052	REGLETA ELECTRONICA 8W	1	1	1	1	1	1	1	1			2	2		
22	6021290057	REGLETA ELECTRONICA 21W T5														1
23	6003010184	CANALIZADOR AGUA 150 GRIS REFRIGERACION	1	1	1	1	1	1	1	1			2	2		1
24	6003010192	CANALIZADOR AGUA 150 NEGRO MANT.CONGEL.						1	1	1	1	1				2
25	6033050016	GUIA GN 2/1 U 662 mm	12	12	12	8	8	14	14	12	12	12	12	12	12	12
26	6027010009	PARRILLA GN 2/1 650X530	6	6	6	4	4	4	4	6	6	6	6	6	6	6
28	A109050557	CREMALL.INT.DPTO.AF-702-C				2	2	4	4							
28	A109050479	CREMALL.INT.AFP-GN	4	4	4	2	2	2	2	4	4	4	4	4	4	4
29	A109050561	CREM.DEL.PEQ.AFP-GN DCHA.		4	8	4	8	4	8		4	8		4		
29	A109050478	CREMALL.DELANT.AFP-GN	4	2		2		2		4	2		4	2	4	4
31	A109170170	REJILLA RESP.MOTOR AFP1600	1	1	1	1	1	1	1	1	1	1				1
31	A109170174	REJILLA RESP.MOTOR AFP 800											2	2	2	
32	A169010190	PUE PEQ AFP CONCEPT IZD			2		2		2			2				
32	A169010191	PUE PEQ AFP/AFN CONCEPT DCHA		2	2	2	2	2	2		2	2		2		
32	A169010188	PUE CARN AFP/AFN CONCEPT IZD	1	1		1		1		1	1		1	1	1	
32	A169010189	PUE CARN AFP/AFN CONCEPT DCHA	1							1			1		1	
33	6045010131	BURLET.1457X636PUERT.CARN.	2	1		1		1		2	1		2	1	2	2
33	6045010132	BURLETA PUERT.PEQ.691X636		2	4	2	4	2	4	2	2	4		2		
35	6033010100	BIS.TRSDOBL MUELLE DV-2608	2	3	4	3	4	3	4		3	4	2	3	2	2
36	A161130023	FRONTI HOR.POST.AF-700,800-C/P				1	1	1	1							
37	A161130021	FRONTI HORZ.POST.AFP MAGNETICO		1	2		1	1	1		1	2		1		
38	A133010001	SOP.BISAG.DV2606 INF DCH. FRES		1	1	1	1	1	1		1	1		1		
39	6033010130	SOP.BISAG.INF.DCH.	1	1	1	1	1	1	1	1	1	1	1	1	1	1
40	6033010140	SOPORTE SUPERIOR BISAGRA DERECHO	1	1	1	1	1	1	1	1	1	1	1	1	1	1
41	A133010000	SOP.BISAG.DV2607 INF IZQ. FRES			1		1		1			1				
42	6033010129	SOP.BISAG.INF.IZD.	1	1	1	1	1	1	1	1	1	1	1	1	1	1
43	6033010141	SOPORTE SUPERIOR BISAGRA IZQUIERDO	1	1	1	1	1	1	1	1	1	1	1	1	1	1
44	6033090104	EJE ROSCA EXT.30X10INOX		1	2	1	2	1	2		1	2		1		
45	6033090064	EJE30x10VARIL INOX ROSC.INT M6	2	2	2	2	2	2	2	2	2	2	2	2	2	2
46	6003010136	CAJA ALOJAMIENTO MUELLE GRIS	2	3	4	3	4	3	4	2	3	4	2	3	2	2
47	6021010003	COMPR.TL-5-G R134A				1	1									
47	6021010002	COMPR.SC-15-CL R404A														1
47	6021010001	COMPR.SC-12-CL R404A						1	1							
48	6003050006	CUBETA DPTO CONGEL.530X540				3	3	3	3							
49	A109050143	FOND. PERF.AGUILAR 530x540x100				3	3									
50	A109050563	BANDEJA GOTEO DPTO.PESCADO				1	1									
51	A109250010	CUBRER.EVAP.FC61B ARM.COMPACTO						1	1				2	2	2	
52	A109050573	DUELAS DPTO.PESC.1400,1600				1	1									
53	6021250051	RESIST.DESES.DEP.PESC.220V425W				1	1									
53	6021250019	RESIST.BLIND.FC61-71 350W						1	1							1
53	6021250081	RESIST.R41 1050W CABLE 1500mm								1	1	1				
54	6021250007	RESIST.MARCO EXT.1400/1600 57W						1	1	1	1	1				
55	6021250010	RESIST.FRONTI V.1400-1600 31W						1	1	1	1	1				
55	6021250009	RESIST. MARCO EXTERIOR 700/800 43w														1
55	6021250008	RESIST.FRONTI H.1400-1600 12W						1	1		1	2				
56	6033050012	GUIA BAJ GN CENT L=613MM Y PES				6	6									
57	A177090020	CONJ. TERM.CONG. 220v 50Hz				1	1	1	1	1	1	1				1
58	6021250005	RESIST.BANDEJA 700-20W								1	1	1				1
58	6021250011	RESIST.BANDEJA DEPART.18W						1	1							

**RECAMBIOS**  
ARMARIOS GASTRO-1600  
OCTUBRE-2012



Зип Обмен  
vsezip.ru

MODELOS

Nº	DESCRIPCIÓN	MODELOS													
		AFP-1602	AFP-1600	AFP-1604	AF-1603-P	AF-1604-P	AF-1603-2	AF-1604-C	AFN-1602	AFN-1603	AFN-1604	AFP-1602/2	AFP-1603/2	AF-1602-MIX	AEP-1602
60	6031070091	PT. CRISTAL ARM 684x1505													2
62	6033010135	TIRAD. PT. CRISTAL													2
63	6029020008	CONDENSADOR 8X2 REF.C CT82DG													
63	6029020005	CONDENSADOR 10x4 TECHO													
63	6029020054	CONDENSADOR VENTILADO 100													1
64	6021050004	VENTIL.5W PATA Y PALA DIAM.200													
68	A109050469	BAND.EVAP.AUT.AFP-GN													1
69	A109170173	TAPA BAN. EVAP.AUT. AFP800													
69	A109170167	TAPA BAN.EVAP.AUT.AFP1600													1
70	6021250073	RESIST.EVAP.AUT.80W 3MT													1
70	6021250078	RESIST.EVAP.AUT.80W 4MT													1
71	6021010035	CONDEN.ARRANQUE SC-117U5017 80 mF													1
71	6021010036	CONDEN.ARRANQUE TL-G 17U5014 60 mF													1
71	6021010037	CONDEN.ARRANQUE FR-117U5015 80 mF													2
71	6021010158	CONDENSADOR COMP. NEK 6210Z													1
72	6021010147	BLOQUE ARRANQUE J2212GK 50HZ													1
73	6021010043	RELE ARRANQUE COMPRESOR SC-15CL 60													1
73	6021010044	RELE ARRANQUE COMPRESOR TL-5G 6000													1
73	6021010025	RELE ARRANQUE COMPRESOR FR-8,5G 2													2
73	6021010156	RELE ARRAN. COMP. NEK 6210Z													1
74	6021130035	CONTA.WEIDMU RPW809730 25A													1
80	A171010107	UD.EVAP.AFP-1400,1600 COMPACTO													1
80	A171010109	UD.EVAP.AFN-1400,1600 COMPACT													1
80	A171010106	UD.EVAP.AFP-700,800,APP COMPAC													2
81	A171010135	UD.EVAP.NEGATIVA 1 CUERPO													1
81	A171010118	UD.EVAP.AF-802-C,1602C COMPACT													1

# Зип Общепит

## LISTADO MODIFICACIONES RESPECTO A ACTUALIZACION Feb-2012

Nº	Mar-2011		Oct-2012		RELACION
	CODIGO	DESCRIPCION	CODIGO	DESCRIPCION	
2	6021130002	INTERRUPTOR UNIPOL.LUMINOS.AMB	6021130006	INTERRUPTOR UNIPOL NEGRO/ROJO	INTERCAMBIABLE
3	6021350021	SONDA CAREL NTC030HP00 3MT	6021350113	SONDA NTC 2,5 MTS	INTERCAMBIABLE
4	A109010735	CABEZA AF-1600 MIXT 2 TERM.	A109010824	CABEZA AF-1600 MIXTO	NO INTERCAMBIABLE
4	A109010455	CABEZA AF-1600-DPTO	A109010823	CABEZA AF-1600 DPTO	NO INTERCAMBIABLE
4	A109010453	CABEZA AFP-1600	A109010816	CABEZA AFP-1600	NO INTERCAMBIABLE
6	6023010408	PEG.CUAD.FAGOR REFR.347,5X60	6023010553	PEG.FAGOR GAMA CONCEPT	NO INTERCAMBIABLE
6	6023010406	PEG.CUAD.FAG ARMAR.DPTO	6023010554	PEG. FAGOR GAMA CONCEPT DPTO	NO INTERCAMBIABLE
7	6021130001	INT.BIP.AMB.O/I CONTAC.REFORZ.	6021130065	INTERRUPTOR BIP. O/I NEGRO/ROJO	INTERCAMBIABLE
8	6021130002	INTERRUPTOR UNIPOL.LUMINOS.AMB	6021130066	INTERRUPTOR UNIPOL. NEGRO/ROJO	INTERCAMBIABLE
9	6021350018	TERMOS REFRI CAREL PYCO1SN515	A177090018	CONJ.TERM. REF. 220v 50Hz	INTERCAMBIABLE
32	A169010090	PUE PEQ AFP/AFN IZD	A169010190	PUE PEQ AFP CONCEPT IZD	INTERCAMBIABLE
32	A169010093	PUE PEQ AFP/AFN DCH	A169010191	PUE PEQ AFP/AFN CONCEPT DCHA	INTERCAMBIABLE
32	A169010081	PUE CAR AFP/AFN IZD	A169010188	PUE CARN AFP/AFN CONCEPT IZD	INTERCAMBIABLE
32	A169010086	PUE CAR AFP/AFN DCH	A169010189	PUE CARN AFP/AFN CONCEPT DCHA	INTERCAMBIABLE
57	6021350010	TERM CAREL CONG.PYCO1LO016	A177090020	CONJ. TERM.CONG. 220v 50Hz	INTERCAMBIABLE
60	6031070067	PUERT. CRIST. AFP IZQ.	6031070091	PT. CRISTAL ARM 684x1505	NO INTERCAMBIABLE
62	6033010002	TIRADOR ASA CROMADA	6033010135	TIRAD. PT. CRISTAL	NO INTERCAMBIABLE

Зип Общепит

ysezip.ru

+7 (812) 987-08-81

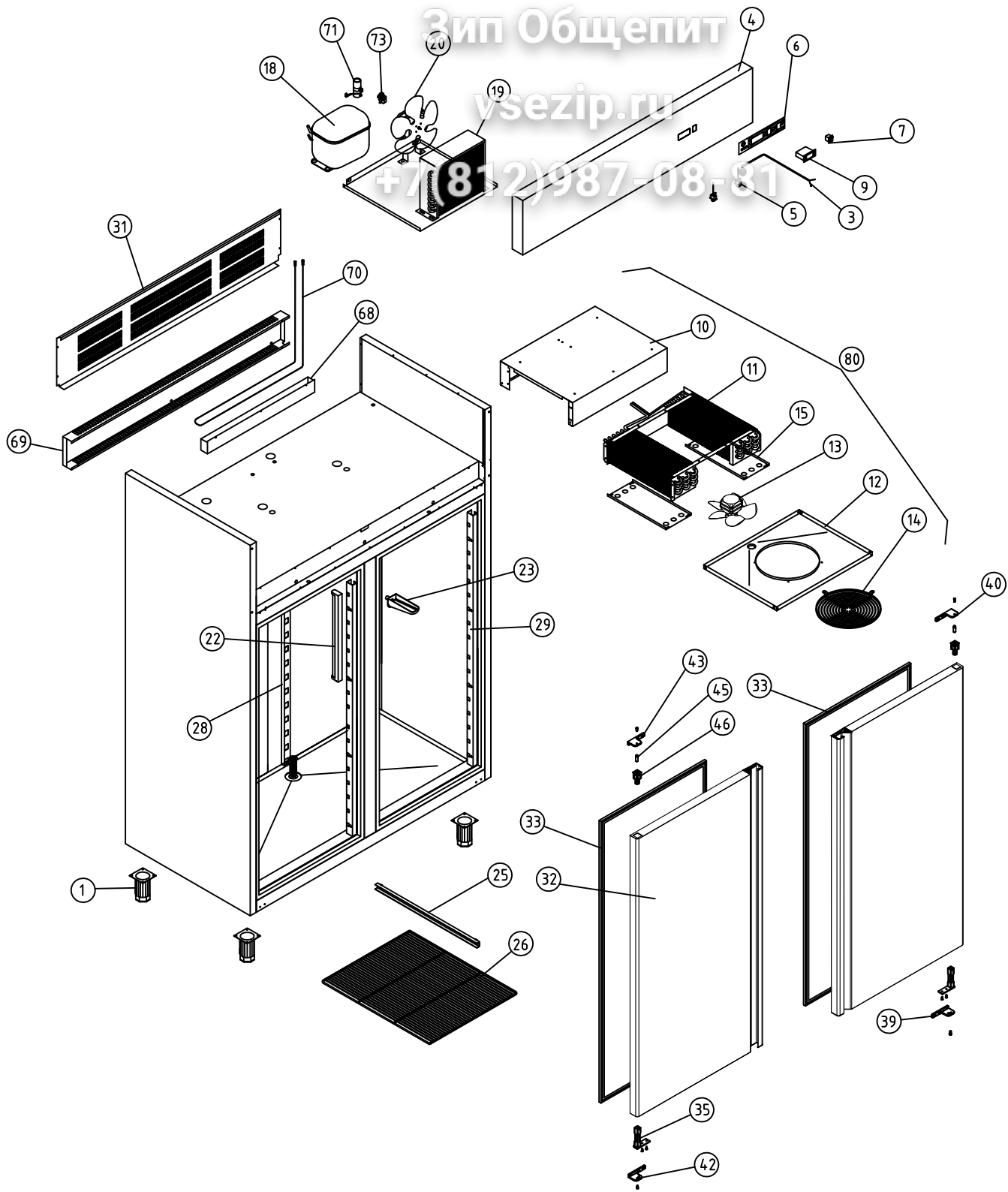

A1 ARMARIOS GASTRONORM COD. PIEZA: X

COTAS SIN TOLERANCIA DIN 7168-f Material: MATERIAL ESPESOR

ANGULAR	GRADO TOLERANCIA	FINO	MEDIO	GRUESO
	HASTA 10 mm		±1°	±1° 30'
	MÁS DE 10 A 50 mm		±30'	±50'
	MÁS DE 50 A 120 mm		±20'	±25'
	MÁS DE 120 A 400 mm		±10'	±15'
MÁS DE 400 mm		±5'	±10'	

Acabado: ACABADO

SUSTITUYE A:

SUSTITUIDO POR:

COMUN A	MODELO	Ud.	MODELO	Ud.	MODELO	Ud.	MODELO	Ud.	MODELO	Ud.
		AFP-1602	1							

LINEAL	GRADO TOLERANCIA	FINO	MEDIO	GRUESO
	HASTA 3 mm	±0,05	±0,10	±0,15
	MÁS DE 3 A 6 mm	±0,05	±0,10	±0,20
	MÁS DE 6 A 30 mm	±0,10	±0,20	±0,50
	MÁS DE 30 A 120 mm	±0,15	±0,30	±0,80
MÁS DE 120 A 400 mm	±0,20	±0,50	±1,20	
MÁS DE 400 A 1000 mm	±0,30	±0,80	±2,00	
MÁS DE 1000 A 2000 mm	±0,50	±1,20	±3,00	

A4	Nombre	Fecha
Dibujado	B. MORENO	Oct-2012
Modificado		
Escala	1:30	



**FAGOR**  
Fagofri, s.a.

RECAMBIOS AFP-1602

Código máquina:  
**CODIGO**

Зип Общепит

7sezip.ru

+7(812)987-08-81

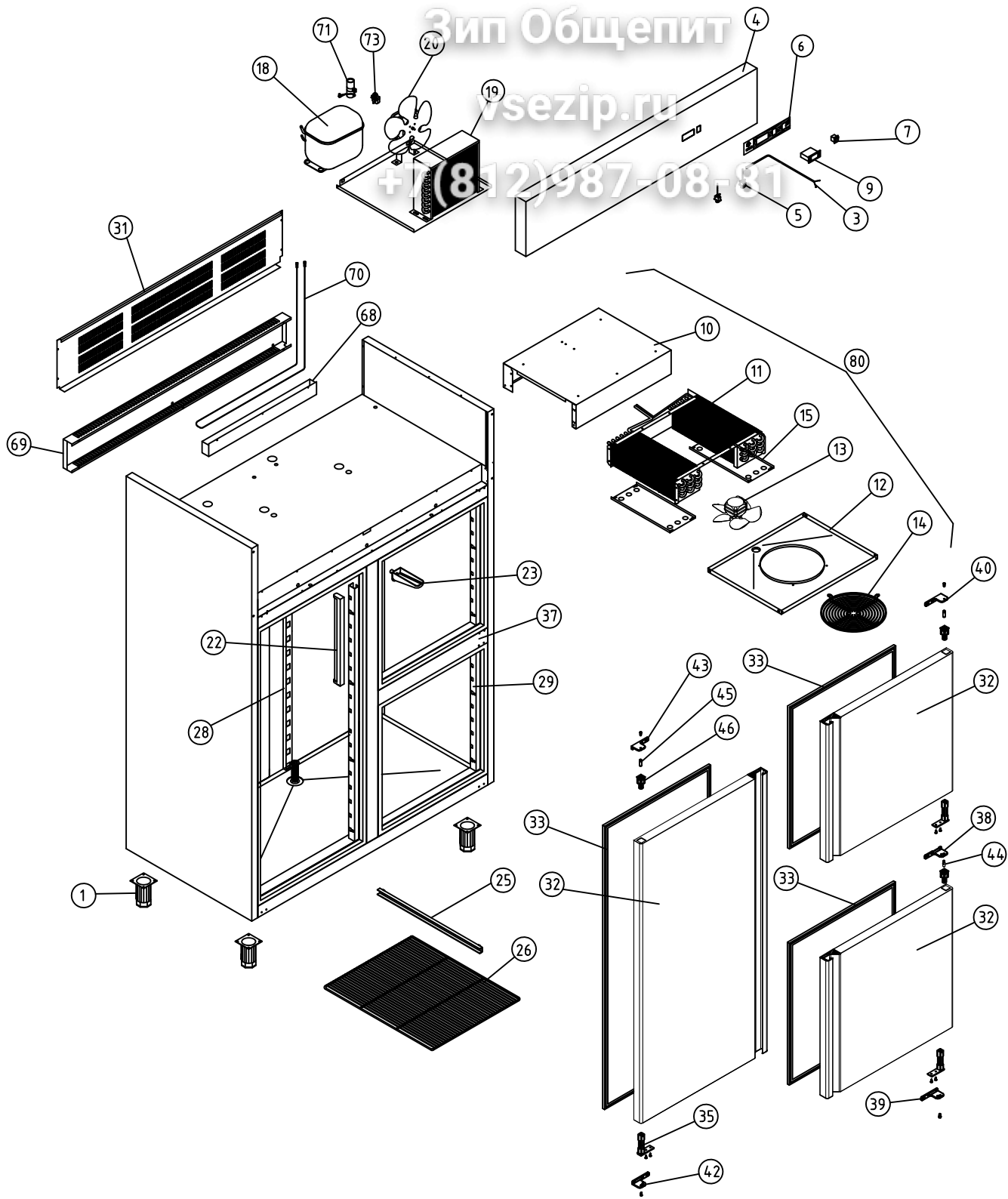

A1 ARMARIOS GASTRONORM COD. PIEZA: X

COTAS SIN TOLERANCIA DIN 7168-f Material: MATERIAL ESPESOR

ANGULAR	GRADO TOLERANCIA	FINO	MEDIO	GRUESO
	HASTA 10 mm		±1°	±1° 30'
	MÁS DE 10 A 50 mm		±30'	±50'
	MÁS DE 50 A 120 mm		±20'	±25'
	MÁS DE 120 A 400 mm		±10'	±15'
MÁS DE 400 mm		±5'	±10'	

Acabado: ACABADO		SUSTITUYE A:							
SUSTITUIDO POR:									
COMUN A	MODELO	Ud.	MODELO	Ud.	MODELO	Ud.	MODELO	Ud.	MODELO
	AFP-1603	1							

LINEAL	GRADO TOLERANCIA	FINO	MEDIO	GRUESO
	HASTA 3 mm	±0,05	±0,10	±0,15
	MÁS DE 3 A 6 mm	±0,05	±0,10	±0,20
	MÁS DE 6 A 30 mm	±0,10	±0,20	±0,50
	MÁS DE 30 A 120 mm	±0,15	±0,30	±0,80
MÁS DE 120 A 400 mm	±0,20	±0,50	±1,20	
MÁS DE 400 A 1000 mm	±0,30	±0,80	±2,00	
MÁS DE 1000 A 2000 mm	±0,50	±1,20	±3,00	

A4	Nombre	Fecha
Dibujado	B. MORENO	Oct-2012
Modificado		
Escala	1:30	



**FAGOR**  
Fagofri, s.a.

RECAMBIOS AFP-1603

Código máquina:  
**CODIGO**

Зип Общепит

vsezip.ru

+7 (812) 987-08-81

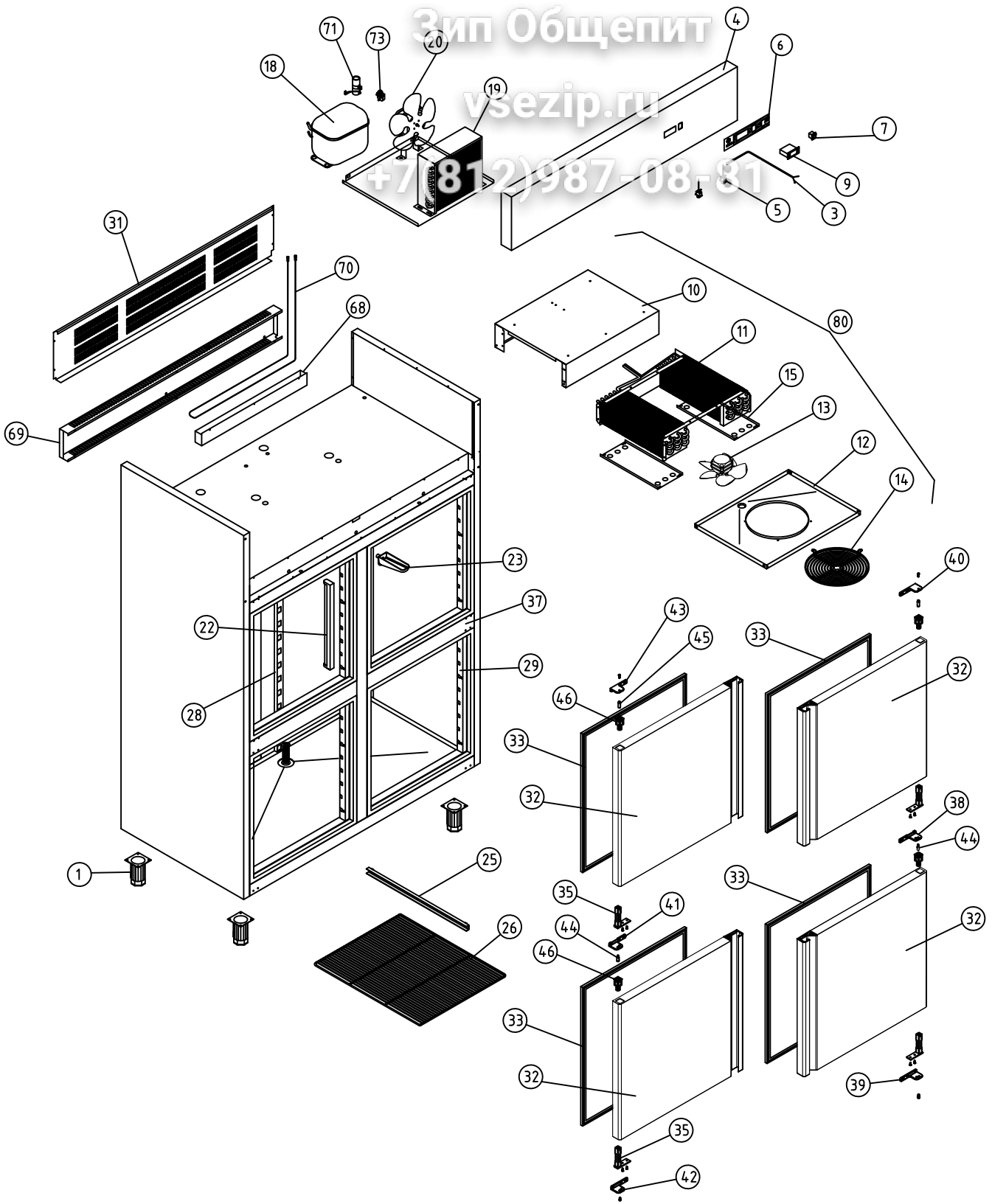

A1 ARMARIOS GASTRONORM

COD. PIEZA: X

COTAS SIN TOLERANCIA DIN 7168-f

Material: MATERIAL ESPESOR

SUSTITUYE A:

Acabado: ACABADO

SUSTITUIDO POR:

ANGULAR	GRADO TOLERANCIA	FINO	MEDIO	GRUESO
	HASTA 10 mm		±1°	±1° 30'
	MAS DE 10 A 50 mm		±30'	±50'
	MAS DE 50 A 120 mm		±20'	±25'
	MAS DE 120 A 400 mm		±10'	±15'
MAS DE 400 mm		±5'	±10'	

COMUN A	MODELO	Ud.	MODELO	Ud.	MODELO	Ud.	MODELO	Ud.	MODELO	Ud.
	AFP-1604	1								

LINEAL	GRADO TOLERANCIA	FINO	MEDIO	GRUESO
	HASTA 3 mm	±0,05	±0,10	±0,15
	MAS DE 3 A 6 mm	±0,05	±0,10	±0,20
	MAS DE 6 A 30 mm	±0,10	±0,20	±0,50
	MAS DE 30 A 120 mm	±0,15	±0,30	±0,80
MAS DE 120 A 400 mm	±0,20	±0,50	±1,20	
MAS DE 400 A 1000 mm	±0,30	±0,80	±2,00	
MAS DE 1000 A 2000 mm	±0,50	±1,20	±3,00	

A4	Nombre	Fecha
Dibujado	B. MORENO	Oct-2012
Modificado		



Escala	1:30	RECAMBIOS AFP-1604	Código máquina: CODIGO
--------	------	--------------------	---------------------------

Зип Общепит

vsezip.ru

+7(812)987-08-81

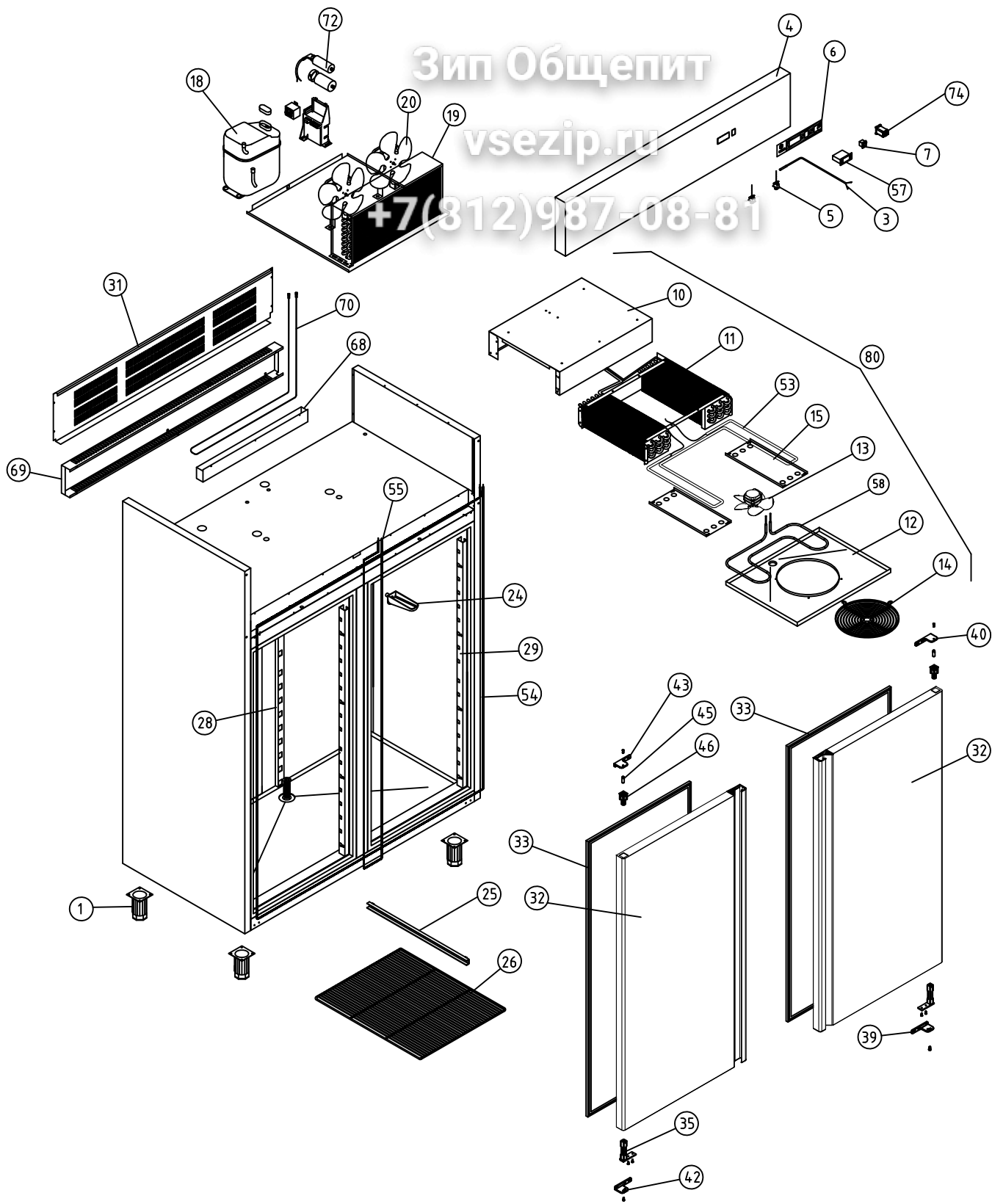

A1 ARMARIOS GASTRONORM MANTENIMIENTO CONGELADOS COD. PIEZA: X

COTAS SIN TOLERANCIA DIN 7168-f SUSTITUYE A:

Material: MATERIAL ESPESOR SUSTITUIDO POR:

Acabado: ACABADO

ANGULAR	GRADO TOLERANCIA	FINO	MEDIO	GRUESO	COMUN A	MODELO	Ud.	MODELO	Ud.	MODELO	Ud.	MODELO	Ud.	MODELO	Ud.
	HASTA 10 mm		±1°			±1° 30'	AFN-1602	1							
MAS DE 10 A 50 mm		±30'		±50'											
MAS DE 50 A 120 mm		±20'		±25'											
MAS DE 120 A 400 mm		±10'		±15'											
MAS DE 400 mm		±5'		±10'											

LINEAL	GRADO TOLERANCIA	FINO	MEDIO	GRUESO	A4	Nombre	Fecha
	HASTA 3 mm		±0,05	±0,10		±0,15	Dibujado
MAS DE 3 A 6 mm		±0,05	±0,10	±0,20	Modificado		
MAS DE 6 A 30 mm		±0,10	±0,20	±0,50			
MAS DE 30 A 120 mm		±0,15	±0,30	±0,80			
MAS DE 120 A 400 mm		±0,20	±0,50	±1,20			
MAS DE 400 A 1000 mm		±0,30	±0,80	±2,00			
MAS DE 1000 A 2000 mm		±0,50	±1,20	±3,00			



Escala: 1:30 RECAMBIOS AFN-1602 Código máquina: CODIGO



Зип Общепит

vsezip.ru

+7(812)987-08-81

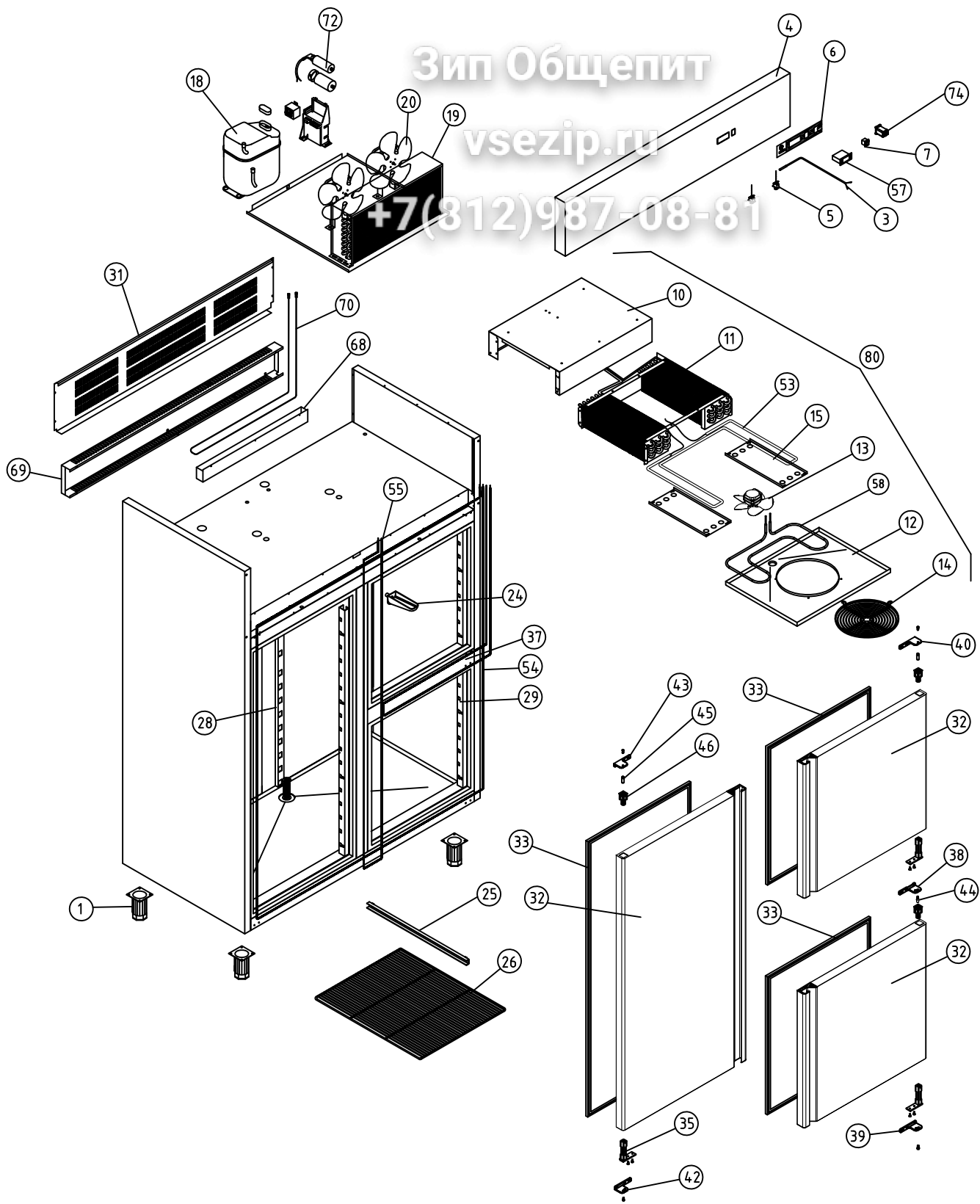

A1 ARMARIOS GASTRONORM MANTENIMIENTO CONGELADOS COD. PIEZA: X

COTAS SIN TOLERANCIA DIN 7168-f Material: MATERIAL ESPESOR

Acabado: ACABADO SUSTITUYE A:

SUSTITUIDO POR:

ANGULAR	GRADO TOLERANCIA	FINO	MEDIO	GRUESO	COMUN A	MODELO	Ud.	MODELO	Ud.	MODELO	Ud.	MODELO	Ud.	
	HASTA 10 mm		±1°	±1° 30'		AFN-1603	1							
	MAS DE 10 A 50 mm		±30'	±50'										
	MAS DE 50 A 120 mm		±20'	±25'										
MAS DE 120 A 400 mm		±10'	±15'											
MAS DE 400 mm		±5'	±10'											

LINEAL	GRADO TOLERANCIA	FINO	MEDIO	GRUESO	A4	Nombre		Fecha	 FAGOR Fagofri, s.a.		
	HASTA 3 mm		±0,05	±0,10		±0,15	Dibujado B.MORENO			Oct-2012	
	MAS DE 3 A 6 mm		±0,05	±0,10		±0,20	Modificado				
	MAS DE 6 A 30 mm		±0,10	±0,20		±0,50	Escala				
MAS DE 30 A 120 mm		±0,15	±0,30	±0,80	1:30						
MAS DE 120 A 400 mm		±0,20	±0,50	±1,20	RECAMBIOS AFN-1603						
MAS DE 400 A 1000 mm		±0,30	±0,80	±2,00							
MAS DE 1000 A 2000 mm		±0,50	±1,20	±3,00							

Código máquina:  
CODIGO

Зип Общепит

vsezip.ru

+7(812)987-08-81

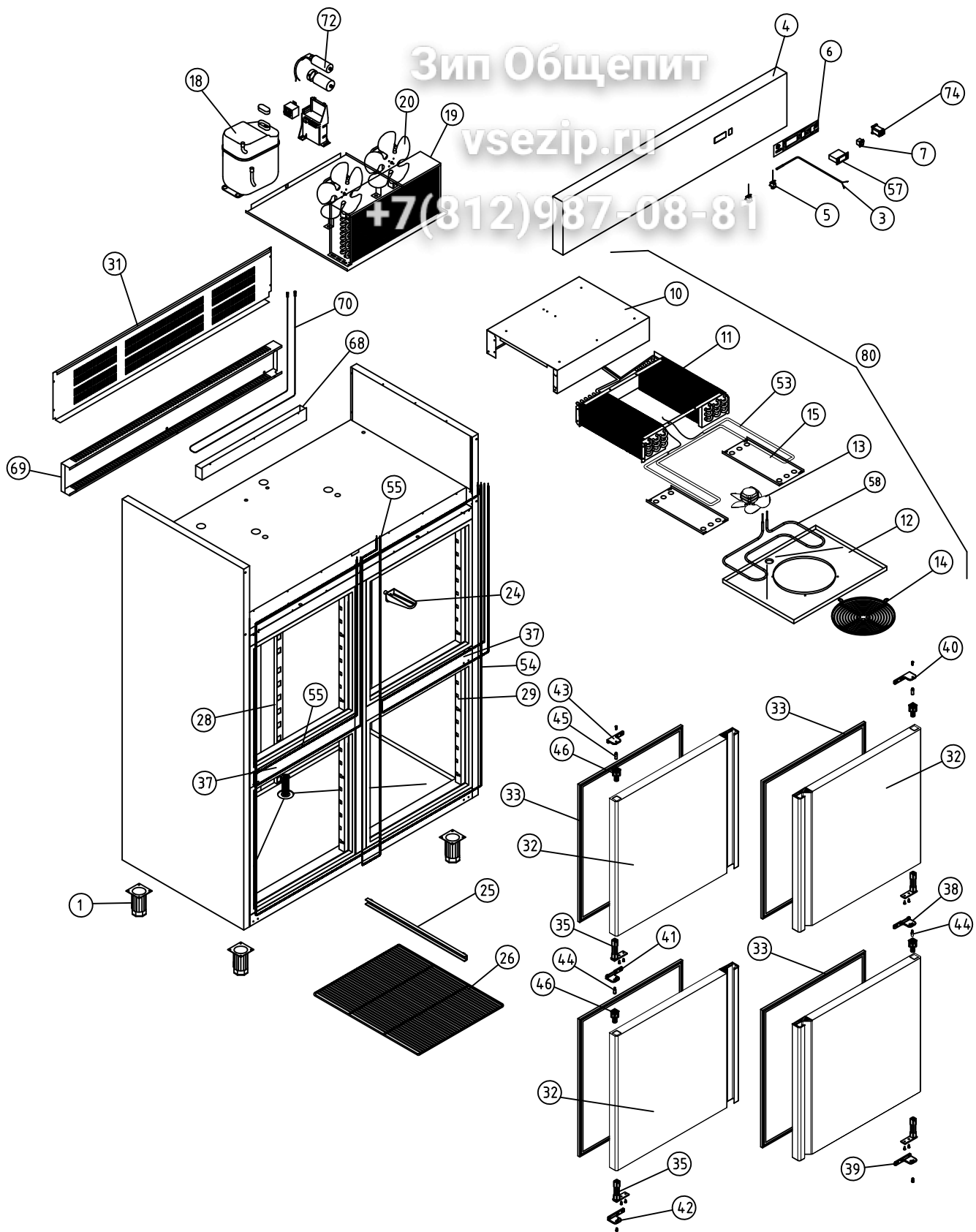

A1 ARMARIOS GASTRONORM MANTENIMIENTO CONGELADOS COD. PIEZA: X

COTAS SIN TOLERANCIA DIN 7168-f

Material: MATERIAL ESPESOR

SUSTITUYE A:

Acabado: ACABADO

SUSTITUIDO POR:

GRADO TOLERANCIA	FINO	MEDIO	GRUESO
HASTA 10 mm	±1°	±1° 30'	
MAS DE 10 A 50 mm	±30'	±50'	
MAS DE 50 A 120 mm	±20'	±25'	
MAS DE 120 A 400 mm	±10'	±15'	
MAS DE 400 mm	±5'	±10'	

COMUN A	MODELO	Ud.	MODELO	Ud.	MODELO	Ud.	MODELO	Ud.	MODELO	Ud.
		AFN-1604	1							

GRADO TOLERANCIA	FINO	MEDIO	GRUESO
HASTA 3 mm	±0,05	±0,10	±0,15
MAS DE 3 A 6 mm	±0,05	±0,10	±0,20
MAS DE 6 A 30 mm	±0,10	±0,20	±0,50
MAS DE 30 A 120 mm	±0,15	±0,30	±0,80
MAS DE 120 A 400 mm	±0,20	±0,50	±1,20
MAS DE 400 A 1000 mm	±0,30	±0,80	±2,00
MAS DE 1000 A 2000 mm	±0,50	±1,20	±3,00

A4	Nombre	Fecha
Dibujado	B. MORENO	Oct-2012
Modificado		



Escala	1:30	RECAMBIOS AFN-1604	Código máquina: CODIGO
--------	------	--------------------	---------------------------



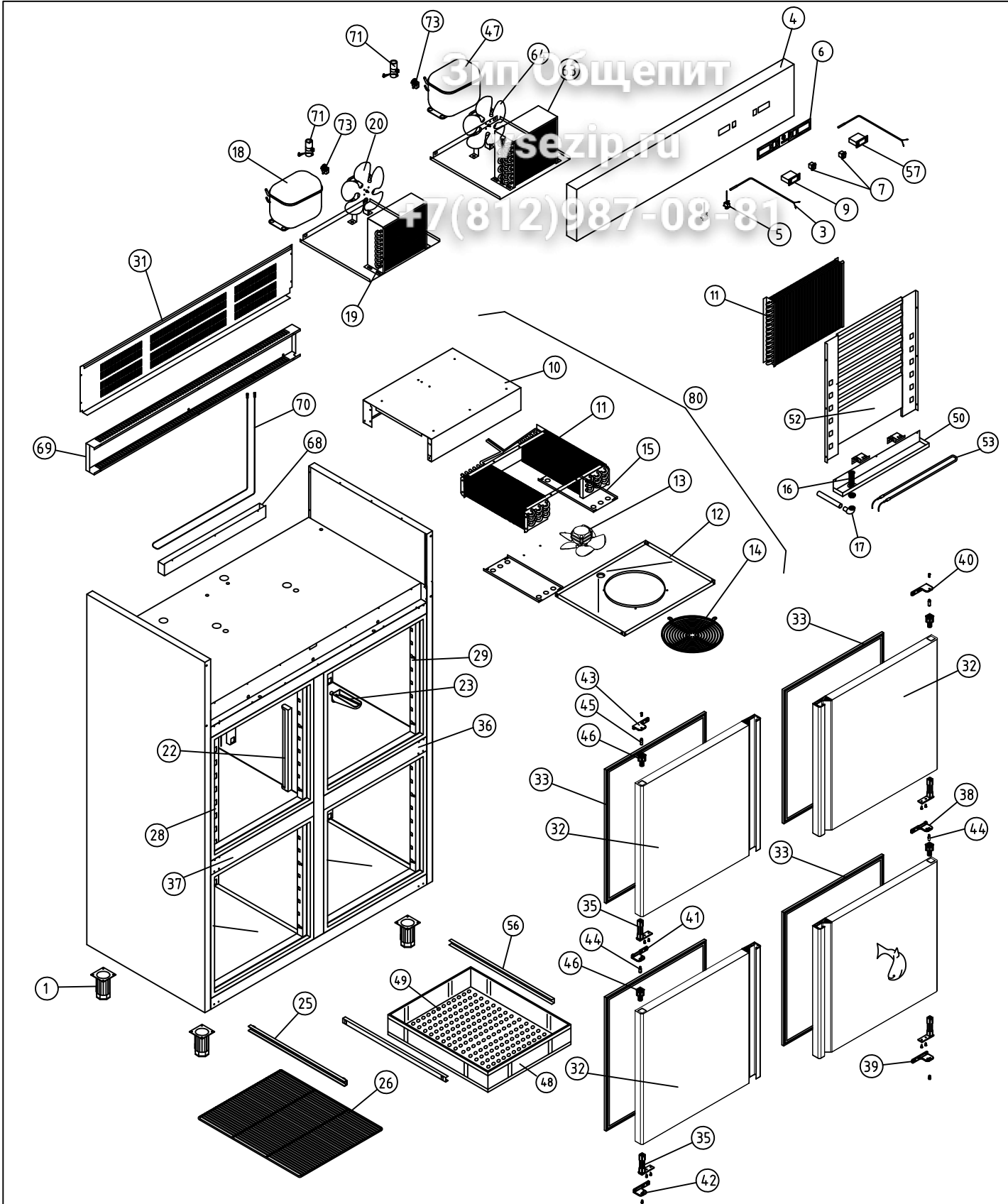

A1 ARMARIOS GASTRONORM DEPARTAMENTO PESCADO						COD. PIEZA: X								
COTAS SIN TOLERANCIA DIN 7168-f						Material: MATERIAL ESPESOR								
Material: MATERIAL ESPESOR						SUSTITUYE A:								
Acabado: ACABADO						SUSTITUIDO POR:								
ANGULAR	GRADO TOLERANCIA	FINO	MEDIO	GRUESO	COMUN A	MODELO	Ud.	MODELO	Ud.	MODELO	Ud.	MODELO	Ud.	
	HASTA 10 mm	±1°		±1° 30'		AF-1604-P	1							
	MAS DE 10 A 50 mm	±30'		±50'										
	MAS DE 50 A 120 mm	±20'		±25'										
LINEAL	MAS DE 120 A 400 mm	±10'		±15'										
	MAS DE 400 mm	±5'		±10'										
	GRADO TOLERANCIA	FINO	MEDIO	GRUESO	A4	Nombre		Fecha		 Fagofri, s.a.				
	HASTA 3 mm	±0,05	±0,10	±0,15	Dibujado	B. MORENO		Oct-2012						
MAS DE 3 A 6 mm	±0,05	±0,10	±0,20	Modificado					Código máquina: <b>CODIGO</b>					
MAS DE 6 A 30 mm	±0,10	±0,20	±0,50	Escala										
MAS DE 30 A 120 mm	±0,15	±0,30	±0,80						<b>RECAMBIOS AF-1604-P</b>					
MAS DE 120 A 400 mm	±0,20	±0,50	±1,20											
MAS DE 400 A 1000 mm	±0,30	±0,80	±2,00											
MAS DE 1000 A 2000 mm	±0,50	±1,20	±3,00											



Элит Общепит

vsap.ru

812)987-08-81

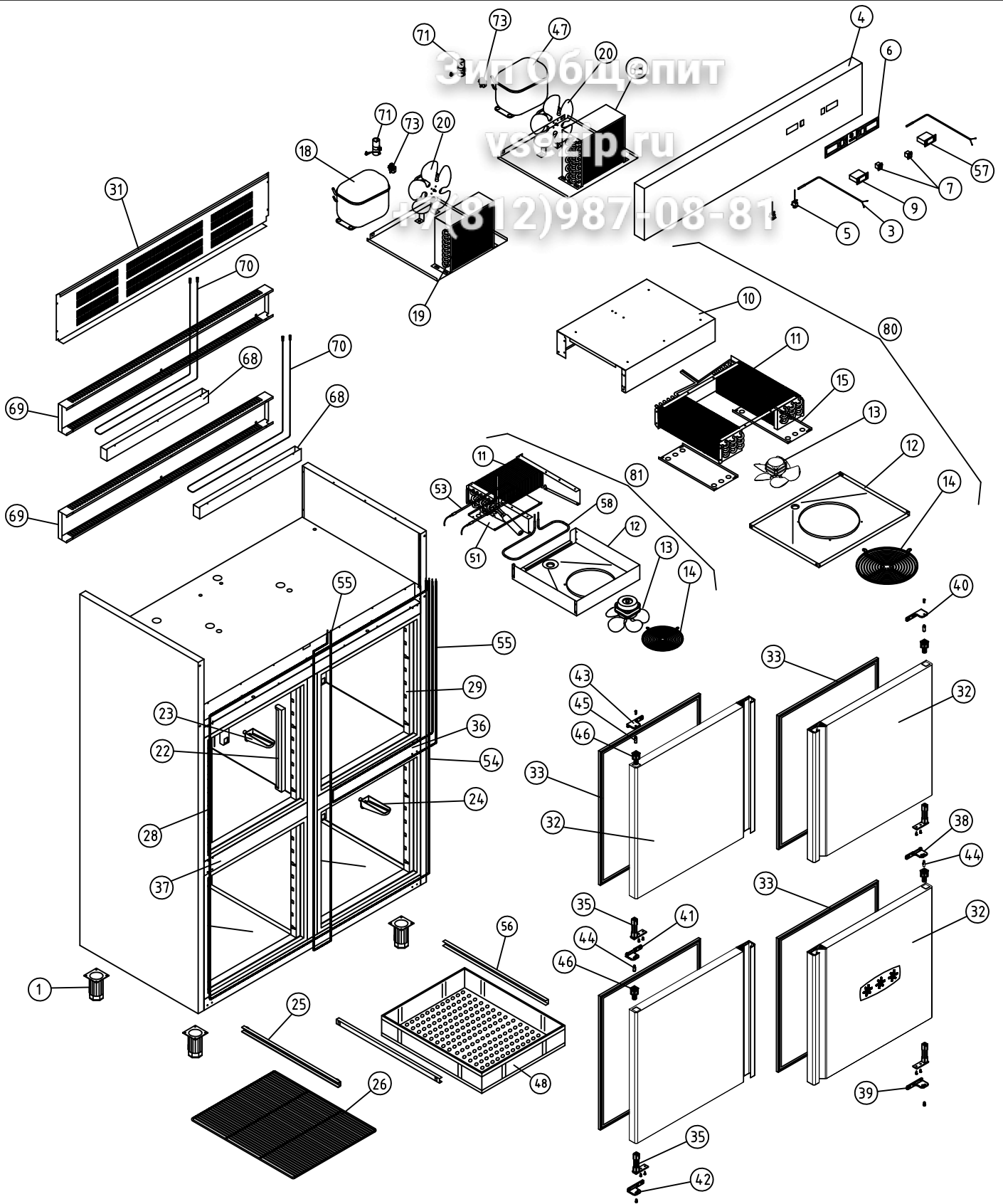

A1 ARMARIOS GASTRONORM DEPARTAMENTO MANTENIMIENTO CONGELADOS

COD. PIEZA: X

COTAS SIN TOLERANCIA DIN 7168-f

Material: MATERIAL ESPESOR

SUSTITUYE A:

GRADO TOLERANCIA	FINO	MEDIO	GRUESO
HASTA 10 mm	±1°	±1° 30'	
MAS DE 10 A 50 mm	±30'	±50'	
MAS DE 50 A 120 mm	±20'	±25'	
MAS DE 120 A 400 mm	±10'	±15'	
MAS DE 400 mm	±5'	±10'	

Acabado: ACABADO

SUSTITUIDO POR:

GRADO TOLERANCIA	FINO	MEDIO	GRUESO
HASTA 3 mm	±0,05	±0,10	±0,15
MAS DE 3 A 6 mm	±0,05	±0,10	±0,20
MAS DE 6 A 30 mm	±0,10	±0,20	±0,50
MAS DE 30 A 120 mm	±0,15	±0,30	±0,80
MAS DE 120 A 400 mm	±0,20	±0,50	±1,20
MAS DE 400 A 1000 mm	±0,30	±0,80	±2,00
MAS DE 1000 A 2000 mm	±0,50	±1,20	±3,00

COMUN A	MODELO	Ud.	MODELO	Ud.	MODELO	Ud.	MODELO	Ud.	MODELO	Ud.
		AF-1604-C	1							

GRADO TOLERANCIA	FINO	MEDIO	GRUESO
HASTA 3 mm	±0,05	±0,10	±0,15
MAS DE 3 A 6 mm	±0,05	±0,10	±0,20
MAS DE 6 A 30 mm	±0,10	±0,20	±0,50
MAS DE 30 A 120 mm	±0,15	±0,30	±0,80
MAS DE 120 A 400 mm	±0,20	±0,50	±1,20
MAS DE 400 A 1000 mm	±0,30	±0,80	±2,00
MAS DE 1000 A 2000 mm	±0,50	±1,20	±3,00

A4	Nombre	Fecha
Dibujado	B. MORENO	Oct-2012
Modificado		



Escala	1:30	RECAMBIOS AF-1604-C	Código máquina: CODIGO
--------	------	---------------------	---------------------------

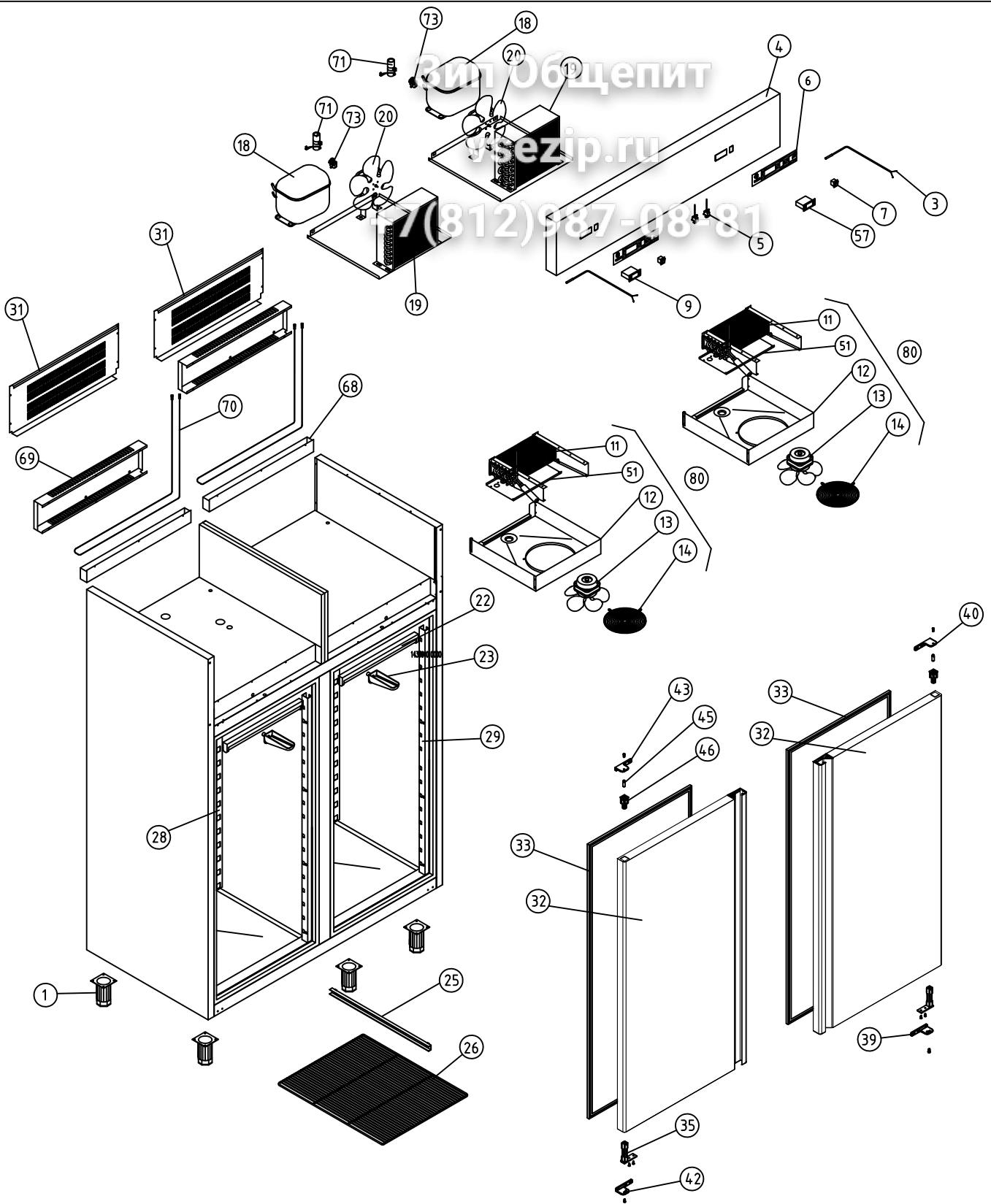

A1 ARMARIOS GASTRONORM DEPARTAMENTO MANTENIMIENTO CONGELADOS COD. PIEZA: X

COTAS SIN TOLERANCIA DIN 7168-f

Material: MATERIAL ESPESOR

SUSTITUYE A:

GRADO TOLERANCIA FINO MEDIO GRUESO

Acabado: ACABADO

SUSTITUIDO POR:

ANGULAR	HASTA 10 mm	±1°	±1° 30'
	MAS DE 10 A 50 mm	±30'	±50'
	MAS DE 50 A 120 mm	±20'	±25'
	MAS DE 120 A 400 mm	±10'	±15'
	MAS DE 400 mm	±5'	±10'

COMUN A	MODELO	Ud.	MODELO	Ud.	MODELO	Ud.	MODELO	Ud.	MODELO
	AF-1602/2	1							

--	--	--	--	--	--	--	--	--	--

LINEAL	GRADO TOLERANCIA	FINO	MEDIO	GRUESO
	HASTA 3 mm	±0,05	±0,10	±0,15
	MAS DE 3 A 6 mm	±0,05	±0,10	±0,20
	MAS DE 6 A 30 mm	±0,10	±0,20	±0,50
	MAS DE 30 A 120 mm	±0,15	±0,30	±0,80
	MAS DE 120 A 400 mm	±0,20	±0,50	±1,20
	MAS DE 400 A 1000 mm	±0,30	±0,80	±2,00
	MAS DE 1000 A 2000 mm	±0,50	±1,20	±3,00

A4	Nombre	Fecha
Dibujado	B. MORENO	Oct-2012
Modificado		
Escala	1:30	

**FAGOR**  
Fagofri, s.a.

RECAMBIOS AFP-1602/2

Código máquina:  
CODIGO

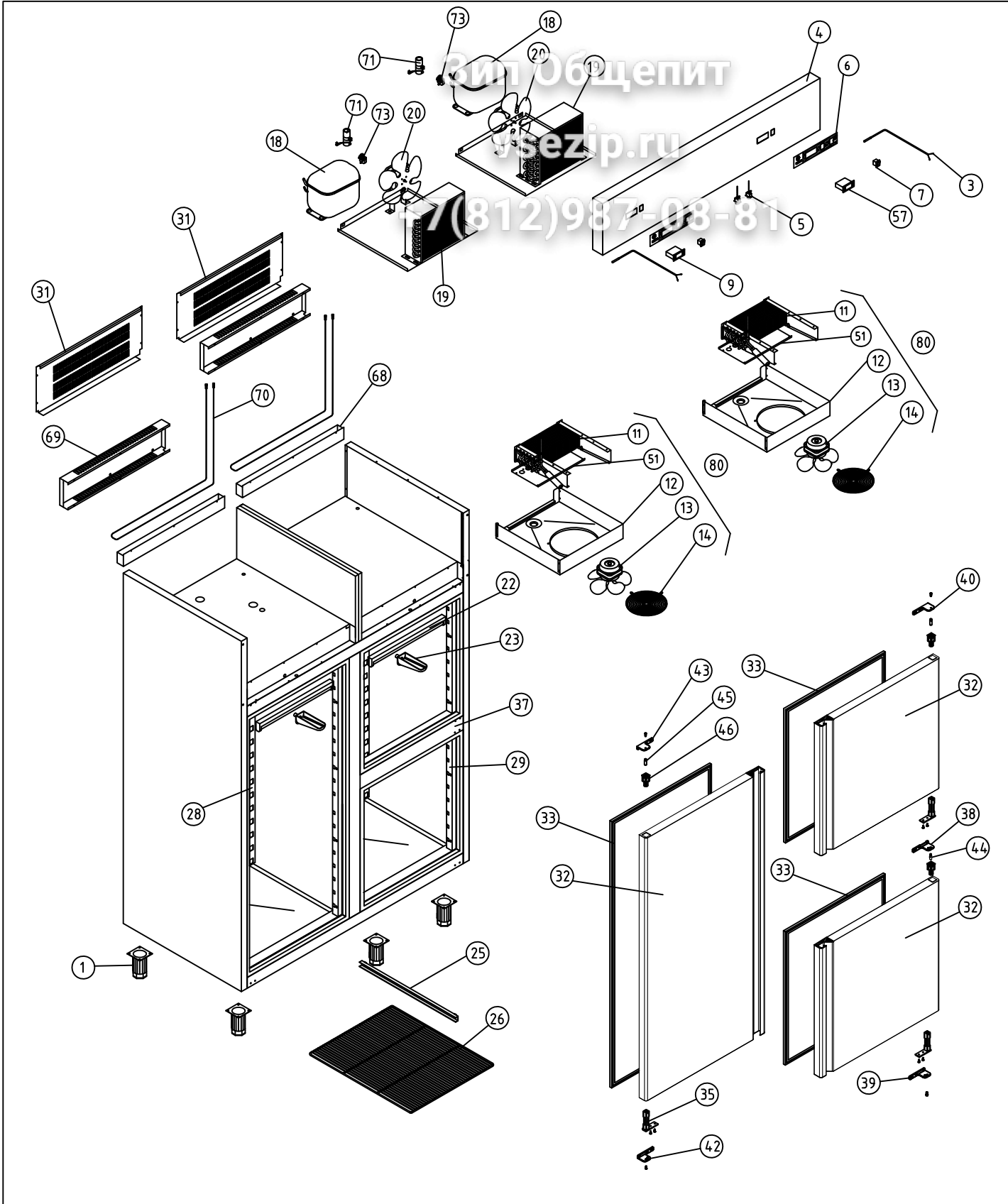

A1 ARMARIOS GASTRONORM DEPARTAMENTO MANTENIMIENTO CONGELADOS						COD. PIEZA: X								
COTAS SIN TOLERANCIA DIN 7168-f						Material: MATERIAL ESPESOR								
Material: MATERIAL ESPESOR						SUSTITUYE A:								
Acabado: ACABADO						SUSTITUIDO POR:								
ANGULAR	GRADO TOLERANCIA	FINO	MEDIO	GRUESO	COMUN A	MODELO	Ud.	MODELO	Ud.	MODELO	Ud.	MODELO	Ud.	
	HASTA 10 mm		±1°	±1° 30'		AF-1603/2	1							
	MAS DE 10 A 50 mm		±30'	±50'										
	MAS DE 50 A 120 mm		±20'	±25'										
LINEAL	MAS DE 120 A 400 mm		±10'	±15'										
	MAS DE 400 mm		±5'	±10'										
	GRADO TOLERANCIA	FINO	MEDIO	GRUESO	A4	Nombre		Fecha		 Fagofri, s.a.				
	HASTA 3 mm	±0,05	±0,10	±0,15	Dibujado	B. MORENO		Oct-2012						
	MAS DE 3 A 6 mm	±0,05	±0,10	±0,20	Modificado									
MAS DE 6 A 30 mm	±0,10	±0,20	±0,50	Escala					Código máquina:					
MAS DE 30 A 120 mm	±0,15	±0,30	±0,80	1:30	RECAMBIOS AFP-1603/2						CODIGO			
MAS DE 120 A 400 mm	±0,20	±0,50	±1,20											
MAS DE 400 A 1000 mm	±0,30	±0,80	±2,00											
MAS DE 1000 A 2000 mm	±0,50	±1,20	±3,00											



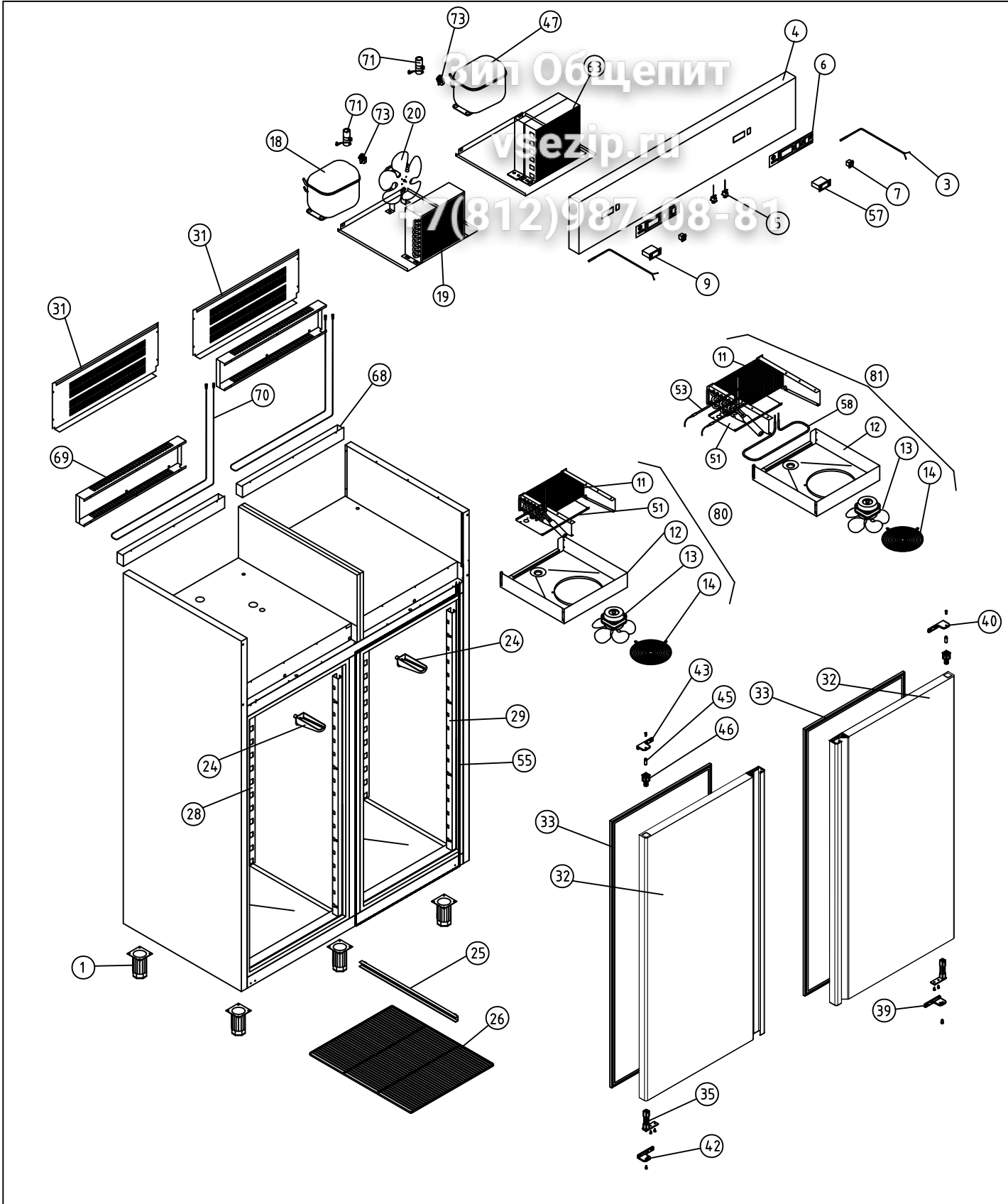



A1 ARMARIOS GASTRONORM						COD. PIEZA: X									
COTAS SIN TOLERANCIA DIN 7168-f						Material: MATERIAL ESPESOR									
Material: MATERIAL ESPESOR						SUSTITUYE A:									
Acabado: ACABADO						SUSTITUIDO POR:									
ANGULAR	GRADO TOLERANCIA	FINO	MEDIO	GRUESO	COMUN A	MODELO	Ud.	MODELO	Ud.	MODELO	Ud.	MODELO	Ud.	MODELO	
	HASTA 10 mm		±1°	±1° 30'		AF-1602-MIX	1								
	MAS DE 10 A 50 mm		±30'	±50'											
	MAS DE 50 A 120 mm		±20'	±25'											
LINEAL	MAS DE 120 A 400 mm		±10'	±15'											
	MAS DE 400 mm		±5'	±10'											
	GRADO TOLERANCIA	FINO	MEDIO	GRUESO	A4	Nombre	Fecha		 Fagofri, s.a.						
	HASTA 3 mm	±0,05	±0,10	±0,15	Dibujado	B. MORENO	Oct-2012								
	MAS DE 3 A 6 mm	±0,05	±0,10	±0,20	Modificado										
MAS DE 6 A 30 mm	±0,10	±0,20	±0,50	Escala	RECAMBIOS AF-1602-MIX					Código máquina:					
MAS DE 30 A 120 mm	±0,15	±0,30	±0,80	1:30						CODIGO					
MAS DE 120 A 400 mm	±0,20	±0,50	±1,20												
MAS DE 400 A 1000 mm	±0,30	±0,80	±2,00												
MAS DE 1000 A 2000 mm	±0,50	±1,20	±3,00												

Зип Общепит

vsezip.ru

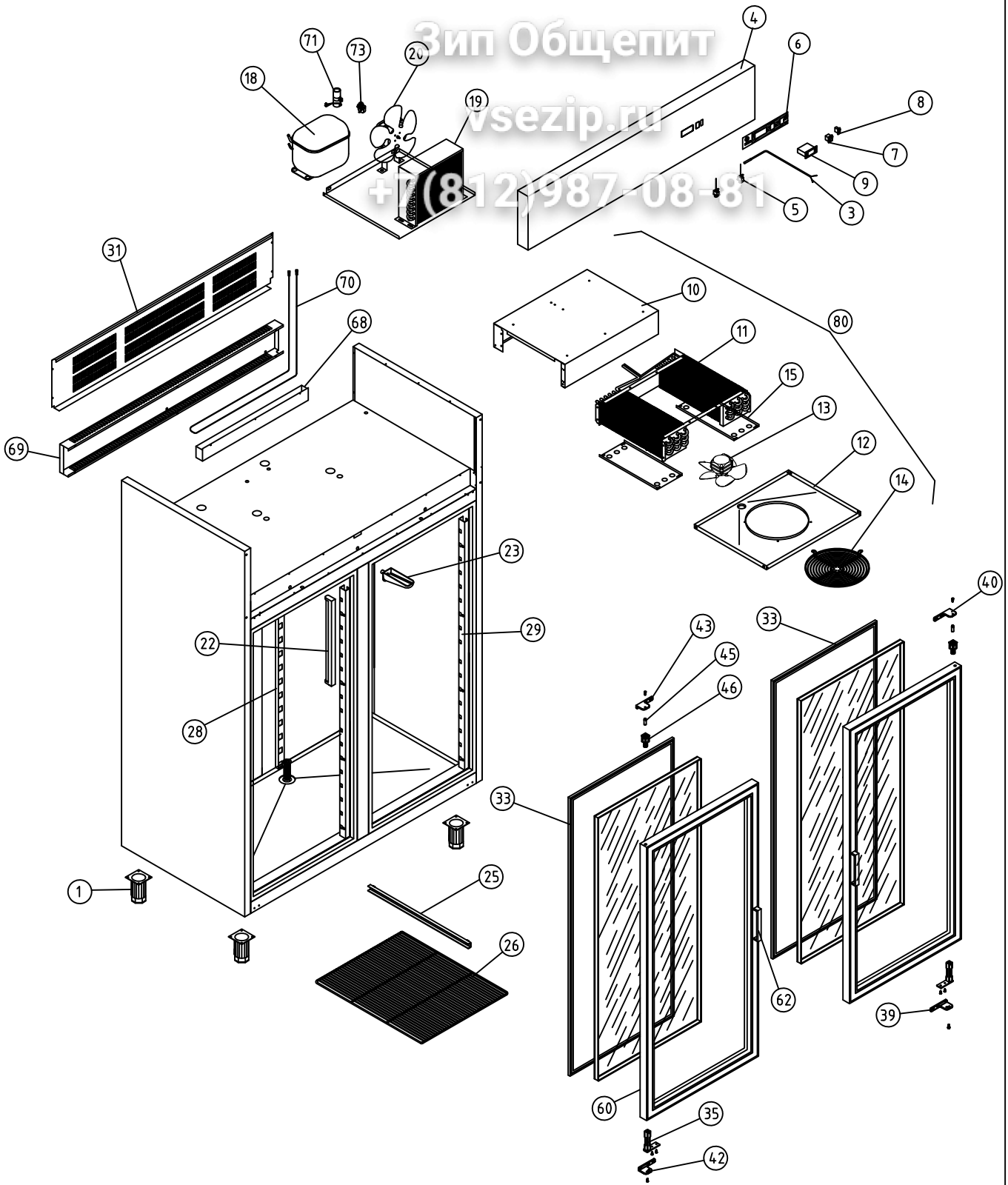
+7(812)987-08-81



A1 ARMARIOS GASTRONORM				COD. PIEZA: X								
COTAS SIN TOLERANCIA DIN 7168-f				Material: MATERIAL ESPESOR								
Material: MATERIAL ESPESOR				SUSTITUYE A:								
Acabado: ACABADO				SUSTITUIDO POR:								
ANGULAR	GRADO TOLERANCIA	FINO	MEDIO	GRUESO								
	HASTA 10 mm	±1°		±1° 30'								
	MÁS DE 10 A 50 mm	±30'		±50'								
	MÁS DE 50 A 120 mm	±20'		±25'								
COMUN A	MÁS DE 120 A 400 mm	±10'		±15'	MODELO	Ud.	MODELO	Ud.	MODELO	Ud.	MODELO	Ud.
	MÁS DE 400 mm	±5'		±10'	AEP-1602	1						
LINEAL	GRADO TOLERANCIA	FINO	MEDIO	GRUESO	A4		Nombre		Fecha		 Fagofri, s.a.	
	HASTA 3 mm	±0,05	±0,10	±0,15	Dibujado		B. MORENO		Oct-2012			
	MÁS DE 3 A 6 mm	±0,05	±0,10	±0,20	Modificado							
	MÁS DE 6 A 30 mm	±0,10	±0,20	±0,50	Escala							
	MÁS DE 30 A 120 mm	±0,15	±0,30	±0,80	1:30		RECAMBIOS AEP-1602				Código máquina:	
	MÁS DE 120 A 400 mm	±0,20	±0,50	±1,20							CODIGO	
MÁS DE 400 A 1000 mm	±0,30	±0,80	±2,00									
MÁS DE 1000 A 2000 mm	±0,50	±1,20	±3,00									