

Зип Общепит

vsezip.ru

DESPIECE TECNICO

+7(812)987-08-81

Hornos eléctricos
Fours électriques
Electric ovens
Elektro heissluftdämpfer
Forni elettrici
Fornos eletricos

Modelos:

COE-102

VE-102

VPE-102

Septiembre 2009 September

Revisado Octubre 2012 / Revised October 2012

FAGOR 

F A G O R I N D U S T R I A L

Зип Общепит

vsezip.ru

+7(812)987-08-81

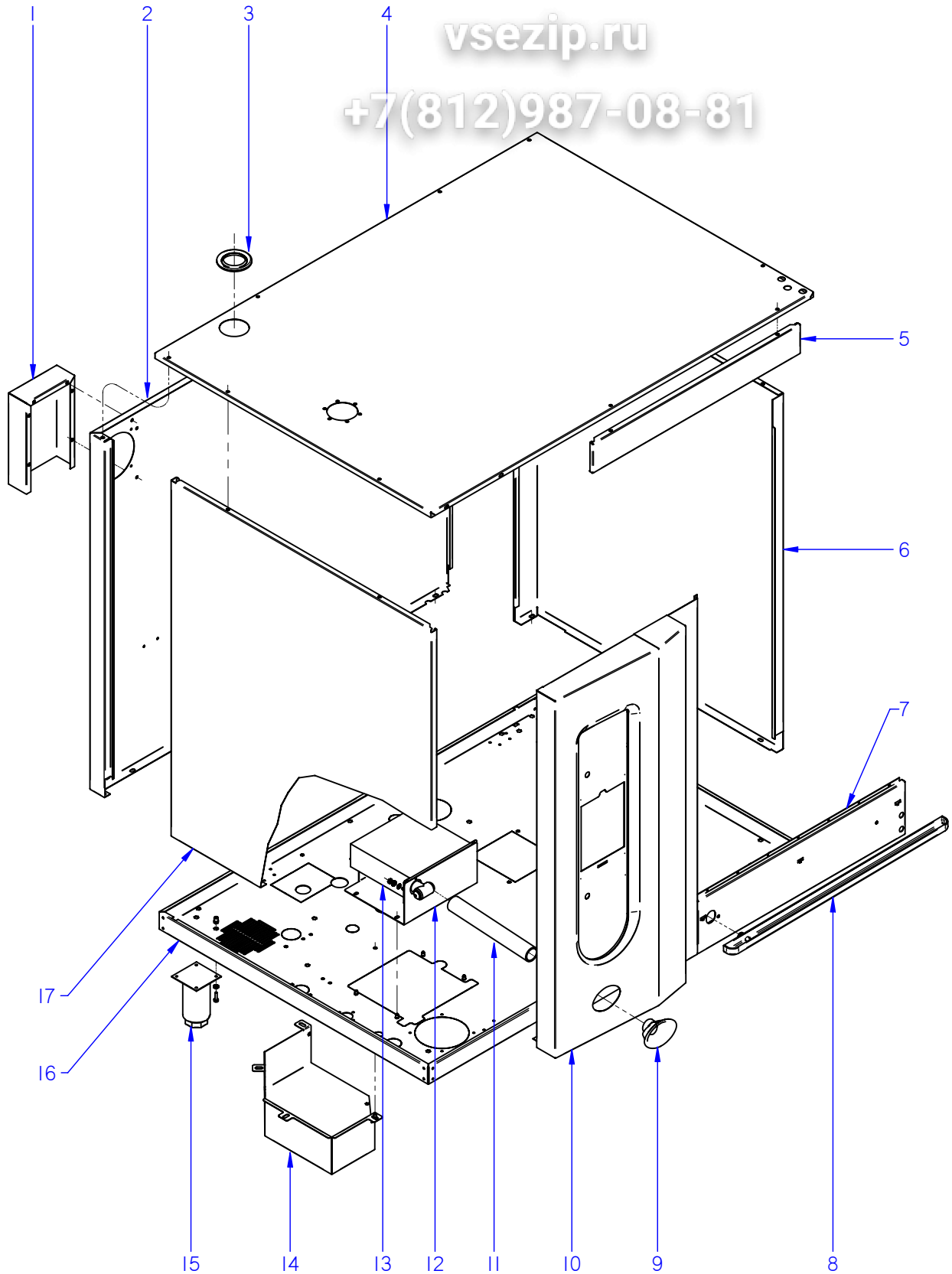

ITEM MARCADO EN COLOR = REPUESTO RECOMENDADO
COLOURED ITEM = RECOMMENDED SPARE PART

N plano	Firma	Fecha	Aparato	MUEBLE	Lamina	Fagor Industrial S.Coop. FAGOR
C-2416	<i>(Signature)</i>	2009-09	HORNOS COE / VE / VPE-102		1	Oñate

MOD.		HORNOS / OVEN		ZONA		MUEBLE / UNIT		
ITEM	CODIGO	DENOMINACION	TEXTO	COE-102	VE-102	VPE-102		
1	T812806500	CHAPA SEPARACION IPX5	SEPARATION PLATE IPX5	1	1	1		
	Q221342000	REMACHE EXAGONAL M5	HEXAGONAL RIVET M.5	6	6	6		
	Q232030000	ARANDELA A5	WASHER A.5	6	6	6		
	Q242030000	ARANDELA ABANICO A5 A.304	FAN SHAPED WASHER A.5	6	6	6		
	Q012031000	TORNILLO EXAGONAL M5x10 A304	HEXAGONAL SCREW M.5x10	6	6	6		
S/Nº	T812811000	JUNTA IPX5	SEAL IPX5	1	1	1		
2	T612802000	PANEL POST. EXTERIOR 10/21	REAR EXTERIOR PANEL10/21	1	1	1		
3	R662813000	PASAMUROS CHIMENEA 101003361	FEED THROUGH FLUE PIPE 1010	1	1	1		
4	T622801000	PANEL SUPER. EXTERIOR 10/21	SUP. EXTERIOR PANEL10/21	1	1	1		
	Q232040000	ARANDELA A6	WASHER A.6	7	7	7		
	Q242040000	ARANDELA ABANICO A6 A.304	FAN SHAPED WASHER A.6	7	7	7		
	Q012042000	TORNILLO EXAGONAL M6x15	HEXAGONAL BOLT M6x15	7	7	7		
	Q152004000	TORNIL. APLASTADO M5X13 A 304	FLAT SCREW M.5x13	7	7	7		
5	T642810000	PANEL FRONTAL SUPERIOR	UPPER FRONT PANEL	1	1	1		
6	T642812000	PANEL EXTERIOR DERECHO 10/21	RIGHT EXT. PANEL 10/21	1	1	1		
7	T642811000	PANEL FRONTAL INFERIOR	LOWER FRONT PANEL	1	1	1		
8	T302853000	RECOGEAGUAS PLASTICO	PLAST SPRING WATER COLLE.	1	1	1		
	Q222041000	REMACHE EXAGONAL M.4 INOX.	HEXAGONAL M.4 INOX.	2	2	2		
	Q242020000	ARANDELA ABANICO A4 A.304	FAN SHAPED WASHER A.4	2	2	2		
	Q032021000	TORNILLO ALOMADO M4x10	CURVED SCREW M.4x10	2	2	2		
9	T922801000	EMBELLECEDOR DUCHA	SHOWER TRIM	-	1	1		
10	T632803000	PANEL PORTAMANDOS 10-21 HEI	CONTROL PANEL 10-21 HEI	1	-	-		
10	T612804000	PANEL PORTAMANDOS 10-21 HEM	CONTROL PANEL 10-21 HEM	-	1	-		
10	T622803000	PANEL PORTAMANDOS 10-21 HEP	CONTROL PANEL 10-21 HEP	-	-	1		
10	T622805000	PANEL PORTAMANDOS VPE-102	CONTROL PANEL VPE-102	-	-	1		
	Q221342000	REMACHE EXAGONAL M5	HEXAGONAL RIVET M.5	3	3	3		
S/Nº	T612806000	JUNTA PORTAMAND. HORZ 10/21	CONTROL HOLDER SEAL HORZ	1	1	1		
11	3714100000	TUBO SILICONA Ø 38*31	SILICON PIPE Ø 38*31	-	1	1		
	Q881305000	ABRAZADERA 25*40	CLAMP 25*40	-	2	2		
12	T642815000	AMARRE DUCHA 10/21 COMPLETO	SHOWER FASTENING	-	1	1		

MOD.		HORNOS / OVEN		ZONA		MUEBLE / UNIT		
ITEM	CODIGO	DENOMINACION	TEXTO	COE-102	VE-102	VPE-102		
13	T452809000	DUCHA	SHOWER		1	1		
S/Nº	T452834000	MANGO DUCHA	SHOWER HANDLE		1	1		
	Q232030000	ARANDELA A5	WASHER A.5		4	4		
	Q242030000	ARANDELA ABANICO A5 A.304	FAN SHAPED WASHER A.5		4	4		
	Q012031000	TORNILLO EXAGONAL M5x10 A304	HEXAGONAL SCREW M.5x10		4	4		
14	T330747000	CAJA CUBRE SISTEMA LAVADO	CLEANING SYSTEM BOX			1		
14	T720705500	CAJA CUBRE SISTEMA LAVADO	CLEANING SYSTEM BOX			1		
14	T330753000	CAJA CUBRE SISTEMA LAVADO	CLEANING SYSTEM BOX			1		
	Q221342000	REMACHE EXAGONAL M.5	HEXAGONAL RIVET M.5			2		
	Q232030000	ARANDELA A5	WASHER A.5			3		
	Q242030000	ARANDELA ABANICO A5 A.304	FAN SHAPED WASHER A.5			3		
	Q012032000	TORNILLO EXAGONAL M5X15	HEXAGONAL BOLT M5X15			3		
S/Nº	T330748000	TAPA CAJA CUBRE SIST LAVADO	COVER WASHING SYSTEM BOX			1		
S/Nº	T720706000	TAPA CAJA CUBRE SIST LAVADO	COVER WASHING SYSTEM BOX			1		
S/Nº	T330752500	TAPA CAJA CUBRE SIST LAVADO	COVER WASHING SYSTEM BOX			1		
S/Nº	T720703000	GUIA2 CAJA CUBRE SIST LAVADO	GUIDE2 WASHING SYSTEM BOX			1		
S/Nº	T720703000	GUIA2 CAJA CUBRE SIST LAVADO	GUIDE2 WASHING SYSTEM BOX			1		
S/Nº	T720704000	GUIA1 CAJA CUBRE SIST LAVADO	GUIDE1 WASHING SYSTEM BOX			1		
S/Nº	T720704000	GUIA1 CAJA CUBRE SIST LAVADO	GUIDE1 WASHING SYSTEM BOX			1		
15	X260151000	PATA REGULABLE	REGULABLE LEG	4	4	4		
	Q232040000	ARANDELA A6	WASHER A.6	16	16	16		
	Q242040000	ARANDELA ABANICO A6 A.304	FAN SHAPED WASHER A.6	16	16	16		
	Q012043000	TORNILLO EXAGONAL M6x20	HEXAGONAL BOLT M6x20	16	16	16		
16	T612801000	BASE EXTERIOR 10/21	EXTERIOR BASE 10/21	1	1	1		
	Q221343000	REMACHE EXAGONAL M.6	HEXAGONAL RIVET M.6	32	32	32		
	Q221342000	REMACHE EXAGONAL M.5	HEXAGONAL RIVET M.5	7	7	7		
17	T642816000	PANEL EXTER. IZQUIERDO 10/21	REAR LEFT PANEL 10/21	1	1	1		
	Q221342000	REMACHE EXAGONAL M.5	HEXAGONAL RIVET M.5	2	2	2		
	Q232040000	ARANDELA A6	WASHER A.6	2	2	2		
	Q012042000	TORNILLO EXAGONAL M6x15	HEXAGONAL BOLT M6x15	2	2	2		
	Q152004000	TORNIL. APLASTADO M5X13 A 304	FLAT SCREW M.5x13	2	2	2		

Зип Общепит

vsezip.ru

+7(812)987-08-81

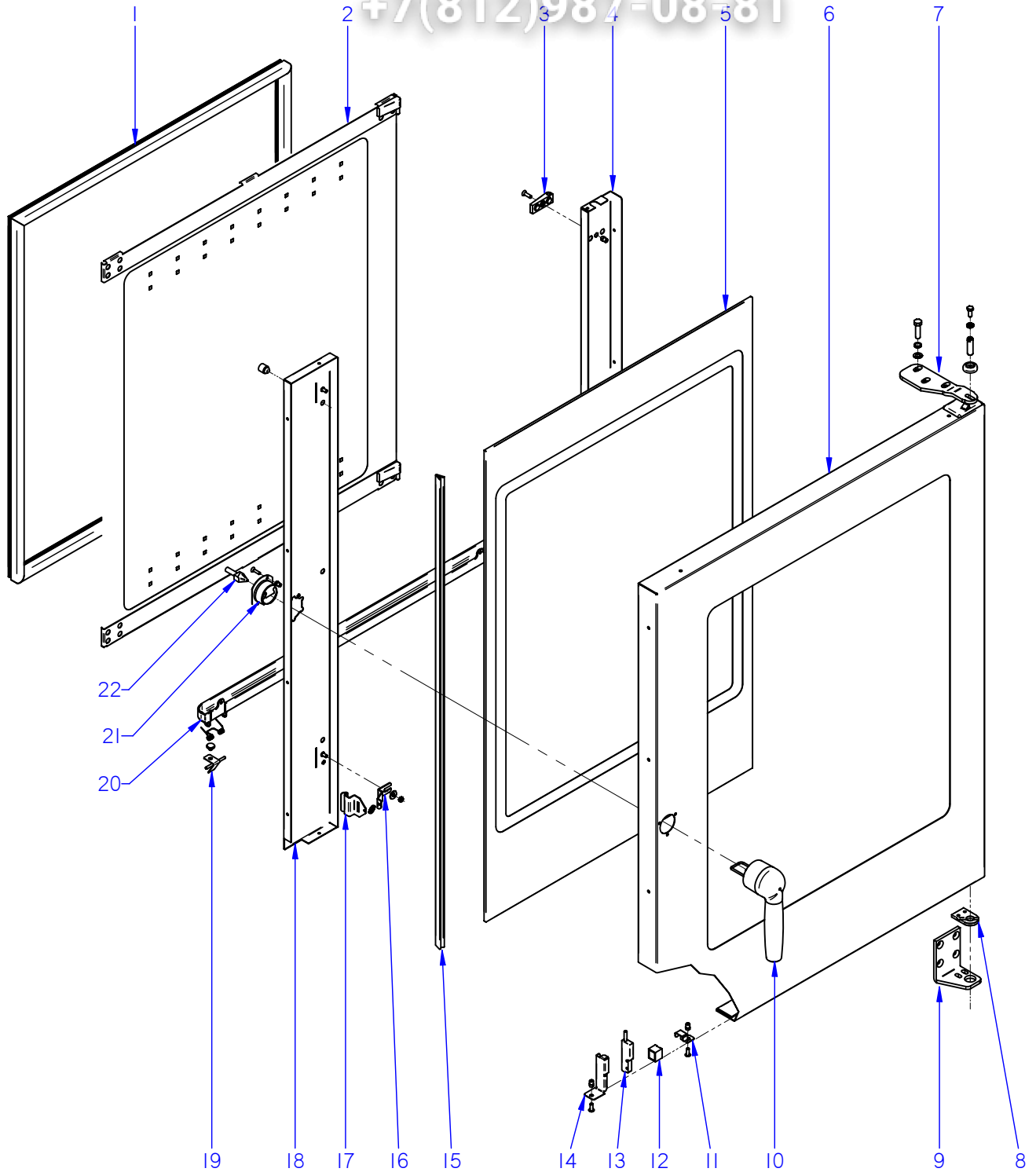

ITEM MARCADO EN COLOR = REPUESTO RECOMENDADO
COLOURED ITEM = RECOMMENDED SPARE PART

N plano	Firma	Fecha	Aparato	PUERTA	Lamina	Fagor Industrial S.Coop. FAGOR
C-2417	<i>[Signature]</i>	2009-09	HORNOS COE / VE / VPE-102		2	Oñate

MOD.		HORNOS / OVEN	ZONA	PUERTA / DOOR				
ITEM	CODIGO	DENOMINACION	TEXTO	COE-102	VE-102	VPE-102		
	1100003143	KIT PUERTA 10/21 COMPL.	DOOR 10/21 KIT	1	1	1		
1	T300500000	JUNTA DE PUERTA 10/21	DOOR JOINT 10/21	1	1	1		
2	1100003136	KIT CRISTAL INTER. 10/21	10/21 INNER GLASS KIT	1	1	1		
3	R670615000	BASE DE BISAGRA	HINGE BASE	2	2	2		
	Q042032000	TORNILLO AVELLANADO M5X15	COUNTERSUNK SCREW M.5x15	2	2	2		
4	T640504000	CONTRAPUERTA BISAGRA 10/21	INNER DOOR HINGE 10/21	1	1	1		
5	T300546000	CRISTAL EXTERIOR 10/21	EXTERNAL GLASS 10/21	1	1	1		
6	T640502000	PANEL PUERTA 10/21	DOOR PANEL 10/21	1	1	1		
7	T300520500	BISAGRA SUPERIOR 10/21	UPPER HINGE 10/21	1	1	1		
7	T300520000	BISAGRA SUPERIOR 21	UPPER HINGE 21	1	1	1		
	Q302025000	ARANDELA 8,4X20X1.5	WASHER 8,4X20X1.5	3	3	3		
	Q261050000	ARANDELA MUELLE A8	SPRING WASHER A8	3	3	3		
	Q012055000	TORNILLO EXAGONAL M8X30	HEXAGONAL BOLT M8X30	3	3	3		
S/Nº	R660534000	EJE SUPERIOR	UPPER SHAFT	1	1	1		
	R662807000	ARANDELA AMARRE	DOOR ANCHORING WASHER	1	1	1		
	Z850519000	RESORTE 06329	SPRING 06329	1	1	1		
8	R660549000	GUIA EJE INFERIOR FUNDIDO	LOWER SHAFT GUIDE	1	1	1		
	Q062040000	TORNILLO AVELLANADO M6X16	COUNTERSUNK SCREW M.6x16	4	4	4		
9	T300521500	BISAGRA INFERIOR PLEGADA	LOWER FOLDER HINGE	1	1	1		
9	T300521000	BISAGRA INFERIOR	LOWER HINGE	1	1	1		
10	T900506000	MANILLA COMPLETA	HANDLE	1	1	1		
	Q042022000	TORNILLO AVELLANADO M4X15	COUNTERSUNK SCREW M.4x15	3	3	3		
11	T130513000	SOPORTE IMAN	MAGNET HOLDER	1	1	1		
	Q222011000	REMACHE EXAGONAL M.5	HEXAGONAL RIVET M.5	1	1	1		
	Q242030000	ARANDELA ABANICO A5 A.304	FAN SHAPED WASHER A.5	1	1	1		
	Q152004000	TORNIL. APLASTADO M5X13 A 304	FLAT SCREW M.5x13	1	1	1		
12	Z200506000	IMAN	MAGNET	1	1	1		
S/Nº	Z200507000	PROTECTOR IMAN	MAGNET PROTECTOR	1	1	1		
13	Z100522000	INTERRUPTOR MAGNETICO AC	MAGNETIC SWITCH AC	1	1	1		
14	T302819000	SOPORTE MICRO PUERTA	DOOR MICRO SWITCH	1	1	1		
	Q152004000	TORNIL. APLASTADO M5X13 A 304	FLAT SCREW M.5x13	1	1	1		

Зип Общежит

vsezip.ru

+7(812)987108-81

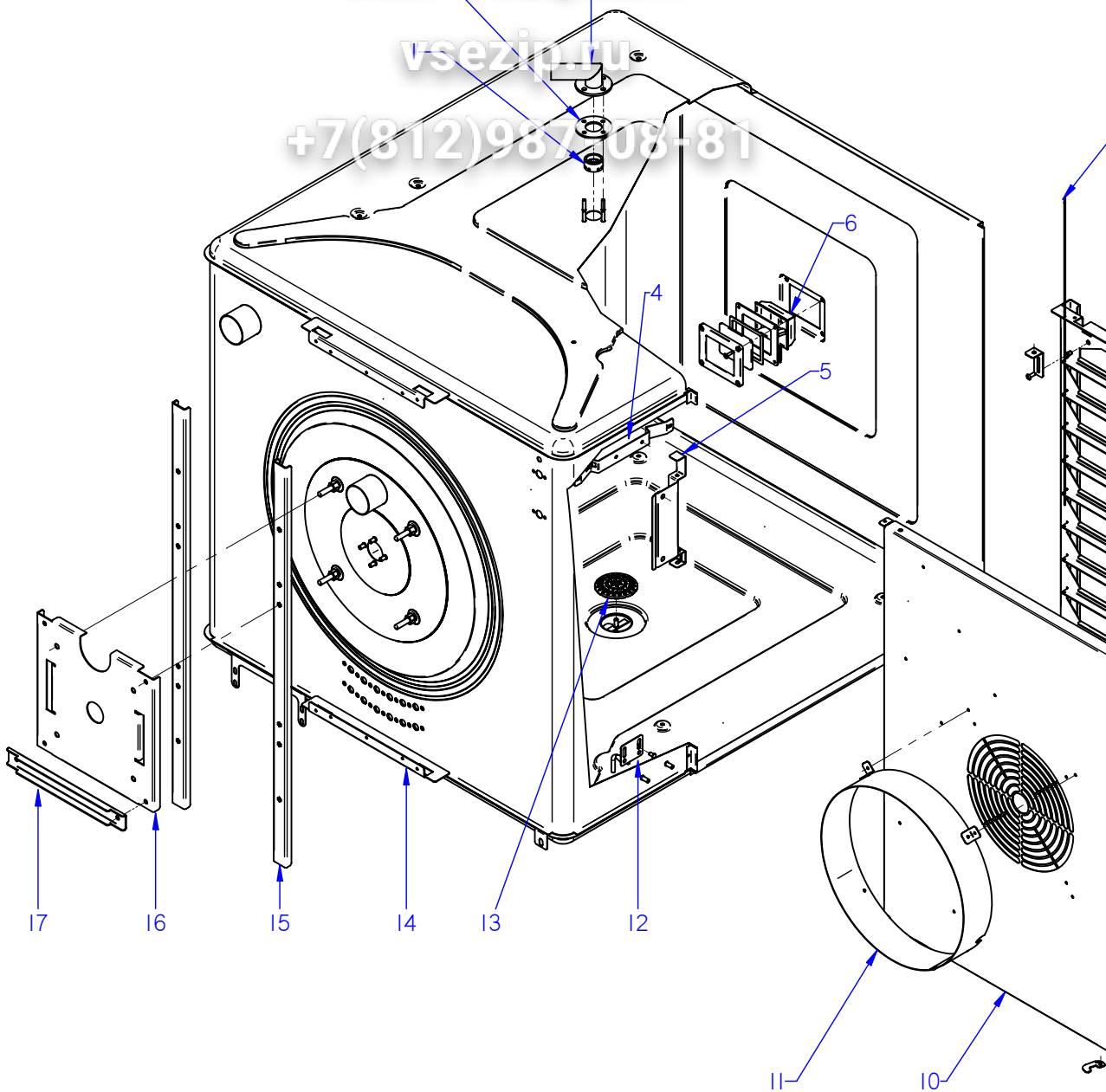

ITEM MARCADO EN COLOR = REPUESTO RECOMENDADO
COLOURED ITEM = RECOMMENDED SPARE PART

N plano	Firma	Fecha	Aparato	Lamina	Fagor Industrial S. Coop.
C-2418	<i>(Firma)</i>	2009-09	HORNOS COE / VE / VPE-102	3	Onate
MUEBLE INTERIOR					



MOD.	HORNOS / OVEN	ZONA	MUEBLE INTERIOR / INTERIOR OVEN					
ITEM	CODIGO	DENOMINACION	TEXTO	COE-102	VE-102	VPE-102		
1	T360712000	PUNTA DIFUSORA LAVADO	WASHING DISPENSER POINT	-	-	1		
2	T330744000	CHAPA AMARRE TUBO LAVADO	WASHING PIPE FASTENING PLAT	-	-	1		
3	T820702000	TUBO DIFUSOR LAVADO COMP.	COMPL. WASHING DISPENSER F	-	-	1		
	Q232030000	ARANDELA A5	WASHER A.5	-	-	4		
	Q242030000	ARANDELA ABANICO A5 A.304	FAN SHAPED WASHER A.5	-	-	4		
	Q162030000	TUERCA EXAGONAL M5	HEXAGONAL NUT M.5	-	-	4		
4	R662683000	SOPORTE BULBO	BULB SUPPORT	1	1	1		
	Q412002000	REMACHE AVINOX Ø4x10MM	TUBULAR RIVET 4x7,5	4	4	4		
5	T302644000	SOPORTE SONDA	PROBE SUPPORT	-	1	1		
	Q232030000	ARANDELA A5	WASHER A.5	-	2	2		
	Q242030000	ARANDELA ABANICO A5 A.304	FAN SHAPED WASHER A.5	-	2	2		
	Q162030000	TUERCA EXAGONAL M5	HEXAGONAL NUT M.5	-	2	2		
6	T303023000	PORTALAMPARAS	LAMP HOLDER	1	1	1		
S/Nº	T303026000	JUNTA EXTERIOR LAMPARA	LAMP OUTER JOINT	1	1	1		
S/Nº	T303025000	CRISTAL LAMPARA	LAMP GLASS	1	1	1		
S/Nº	T303027000	JUNTA INTERIOR LAMPARA	LAMP INNER JOINT	1	1	1		
S/Nº	T303047000	MARCO LAMPARA	LAMP ANCHORING PLATEN	1	1	1		
S/Nº	R663013000	LAMPARA 10W-12V	LIGHT 10W 12V	1	1	1		
	Q222041000	REMACHE EXAGONAL M.4 INOX	HEXAGONAL RIVET M.4	4	4	4		
	Q032021000	TORNILLO ALOMADO M4X10	CURVED SCREW M.4x10	4	4	4		
7	T302692000	TOPE DE BANDEJAS 10/21	TRAY HOLDER BUFFER 10/21	2	2	2		
8	T322611000	PORTABANDEJAS 10/21	TRAY HOLDER 10/21	2	2	2		
S/Nº	T302688000	ENGANCHE PORTABANDEJAS	TRAY HOLDER FASTENER	2	2	2		
	Q222041000	REMACHE EXAGONAL M.4	HEXAGONAL RIVET M.4	2	2	2		
	Q232020000	ARANDELA A4	WASHER A.4	2	2	2		
	Q242020000	ARANDELA ABANICO A4	FAN SHAPED WASHER A.4	2	2	2		
	Q032021000	TORNILLO ALOMADO M4x10	CURVED SCREW M.4x10	2	2	2		
S/Nº	T302690000	CIERRE PORTABANDEJAS 10/21	TRAY HOLDER CLOSURE 10/21	2	2	2		
	Q412002000	REMACHE AVINOX Ø4x10	RIVET AVINOX Ø4x10	2	2	2		
9	T302618000	PROTECCION INTERIOR	INTERIOR PROTECTION	1	1	1		

Зип Общепит

vsezip.ru

+7(812)987-08-81

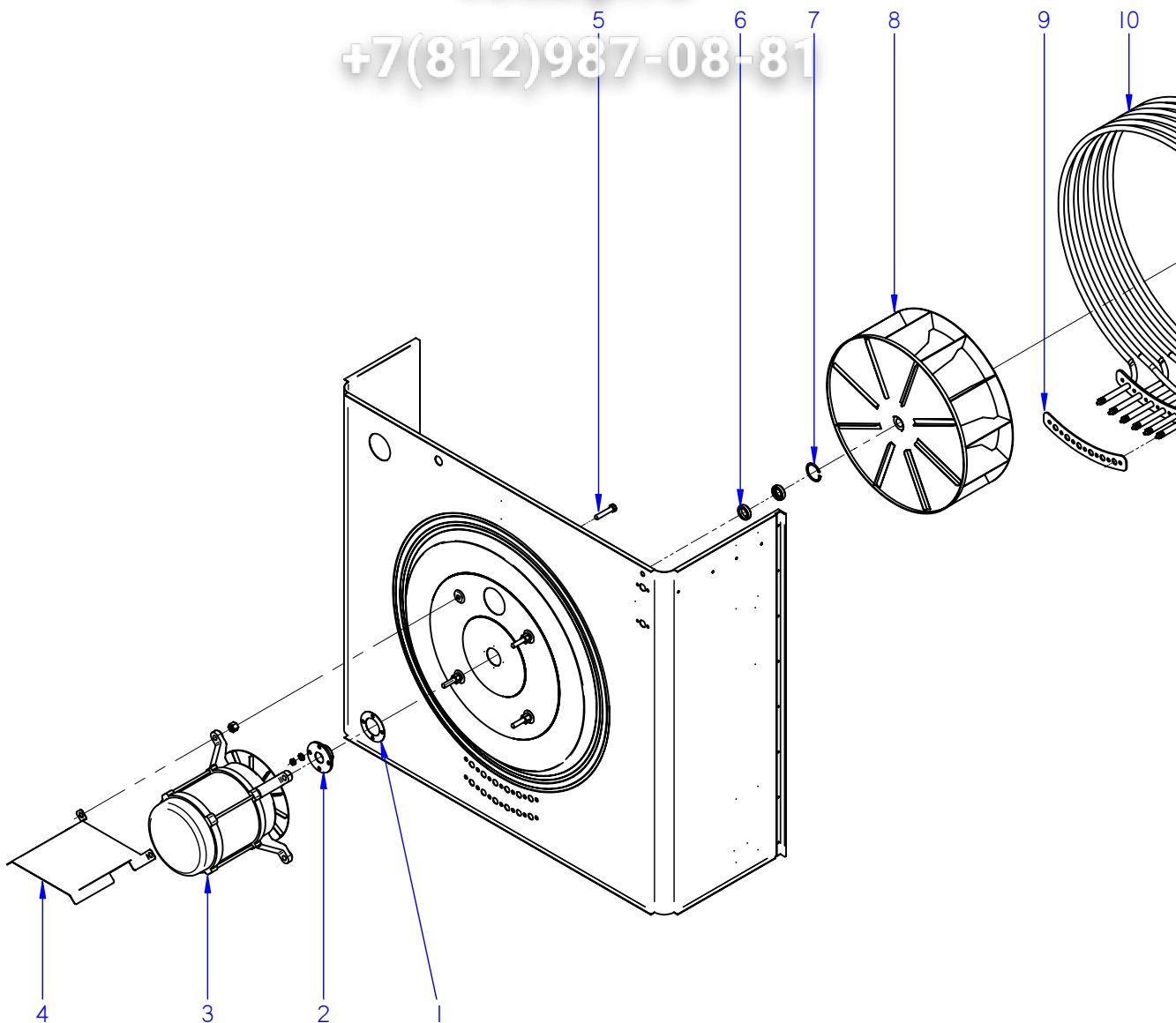

ITEM MARCADO EN COLOR = REPUESTO RECOMENDADO
COLOURED ITEM = RECOMMENDED SPARE PART

N plano	Firma	Fecha	Aparato	Lamina	Fagor Industrial S. Coop. FAGOR Onate
C-2419	<i>[Signature]</i>	2009-09	HORNOS COE / VE / VPE-102	4	

TURBINA

Зип Общепит

vsezip.ru

+7(812)987-08-81

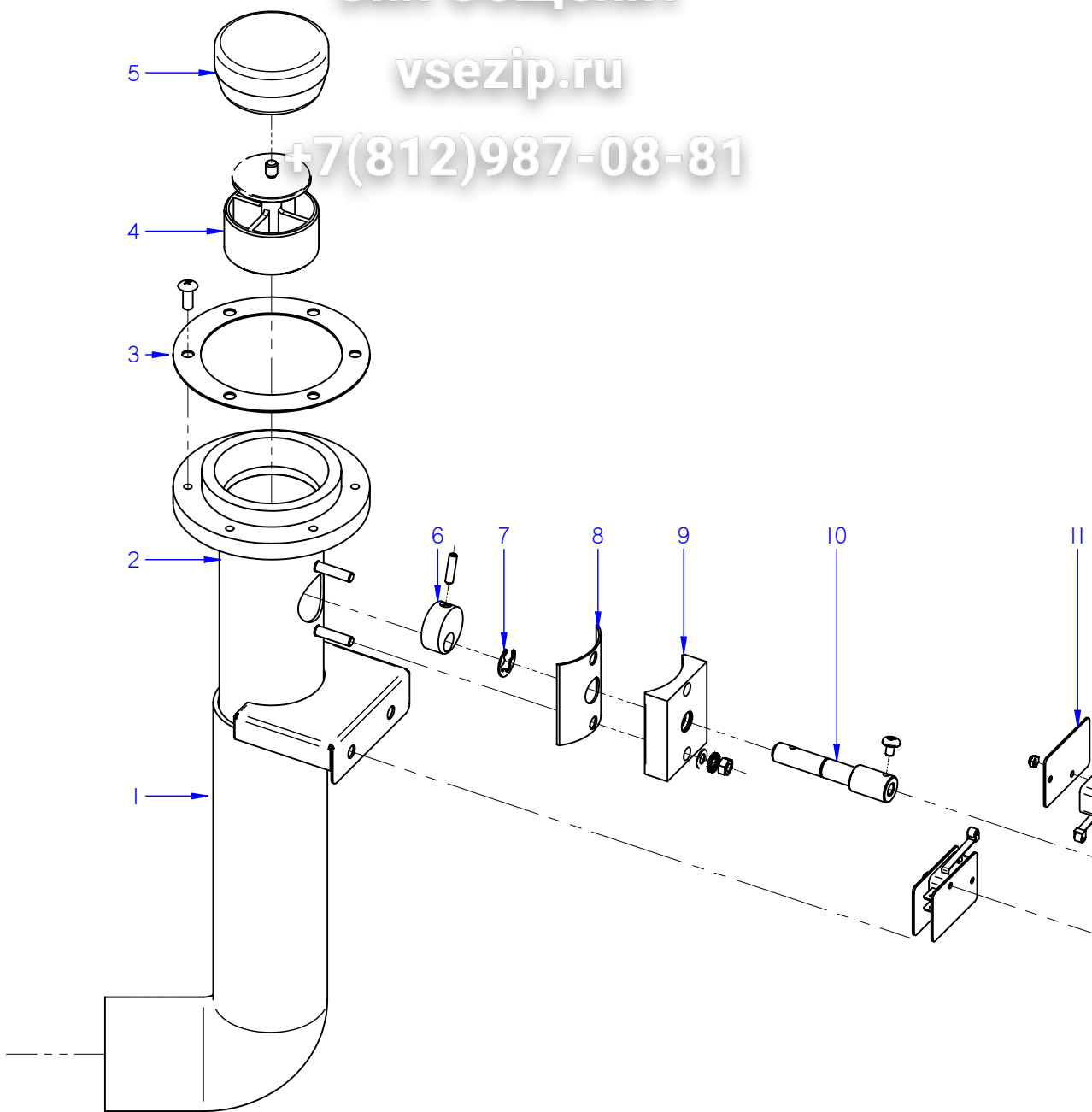

ITEM MARCADO EN COLOR = REPUESTO RECOMENDADO
COLOURED ITEM = RECOMMENDED SPARE PART

N plano	Firma	Fecha	Aparato	Lamina	Fogor Industrial s. Coop.
C-2420	<i>[Signature]</i>	2009-09	HORNOS COE / VE / VPE-102	5	Ornate
			CHIMENEA	FAGOR	

MOD.		HORNOS / OVEN		ZONA		CHIMENEA / FLUEPIPE		
ITEM	CODIGO	DENOMINACION	TEXTO	COE-102	VE-102	VPE-102		
1	T722608000	TUBO FLEXIBLE Ø53X360	FLEXIBLE TUBE Ø53X360	1	1	1		
	Q881307000	ABRAZADERA 40*60	CLAMP 40*60	2	2	2		
2	T815006000	CONJUNTO CHIMENEA	COMPLETE CHIMNEY	1	1	1		
	Q221343000	REMACHE EXAGONAL M.6	HEXAGONAL RIVET M.6	2	2	2		
3	T325057000	JUNTA BASE CHIMENEA	FLUEPIPE BASE SEAL	1	1	1		
	Q152004000	TORNIL. APLASTADO M5X13 A 304	FLAT SCREW M.5x13	6	6	6		
4	T815014000	GUIA RETENCION VAPORES	STEAM RETAINER GUIDE	1	1	1		
5	T325055000	RETENCION DE VAPORES	CLOSE CHIMNEY	1	1	1		
6	T325032000	LEVA EJE CHIMENEA	FLUEPIPE SHAFT CAM	1	1	1		
	Q132045000	VARILLA ROSCADA M4X16	THREADED ROD M4X16	1	1	1		
7	Q271006000	ARANDELA DE SEGURIDAD Ø8	SAFETY WASHER Ø8	1	1	1		
8	T325030000	JUNTA EJE CHIMENEA	FLUEPIPE SHAFT SEAL	1	1	1		
9	T325029000	GUIA EJE CHIMENEA	FLUEPIPE SHAFT GUIDE	1	1	1		
	Q232030000	ARANDELA A5	FLAT WASHER A.5	2	2	2		
	Q242030000	ARANDELA ABANICO A5 A.304	FAN SHAPED WASHER A.5	2	2	2		
	Q162030000	TUERCA EXAGONAL M5	HEXAGONAL NUT M.5	2	2	2		
10	T815010000	EJE CHIMENEA ELECTRICA	ELECTRIC FLUEPIPE SHAFT	1	1	1		
	Q151320000	TORNILLO ALOMADO M4X6 ZINC.	CURVED SCREW M4X6 ZINC.	1	1	1		
11	R010535000	PLACA SEPARADORA	SPACER PLATE	4	4	4		
	Q032013000	TORNILLO ALOMADO M3X20	CURVED SCREW M3X20	4	4	4		
	Q221350000	TUERCA AUTOBLOCANTE M3	SELF-LOCKING NUT M3	4	4	4		
12	R010534000	INTERRUPTOR PUERTA	DOOR SWITCH	2	2	2		
13	T815009000	ESCUA. AMARRE MOTOR CHIMEN.	FLUEPIPE MOTOR FASTENING B	1	1	1		
	Q232040000	ARANDELA A6	FLAT WASHER A.6	2	2	2		
	Q242040000	ARANDELA ABANICO A6 A.304	FAN SHAPED WASHER A.6	2	2	2		
	Q012042000	TORNILLO EXAGONAL M6X15 A304	HEXAGONAL SCREW M6X15	2	2	2		
14	Q308006000	ARANDELA DUBO Ø 4	WASHER DUBO Ø 4	3	3	3		
15	T323010000	MOTOR CHIMENEA	FLUEPIPE MOTOR	1	1	1		

Зип Общепит

vsezip.ru

+7(812)987-08-81

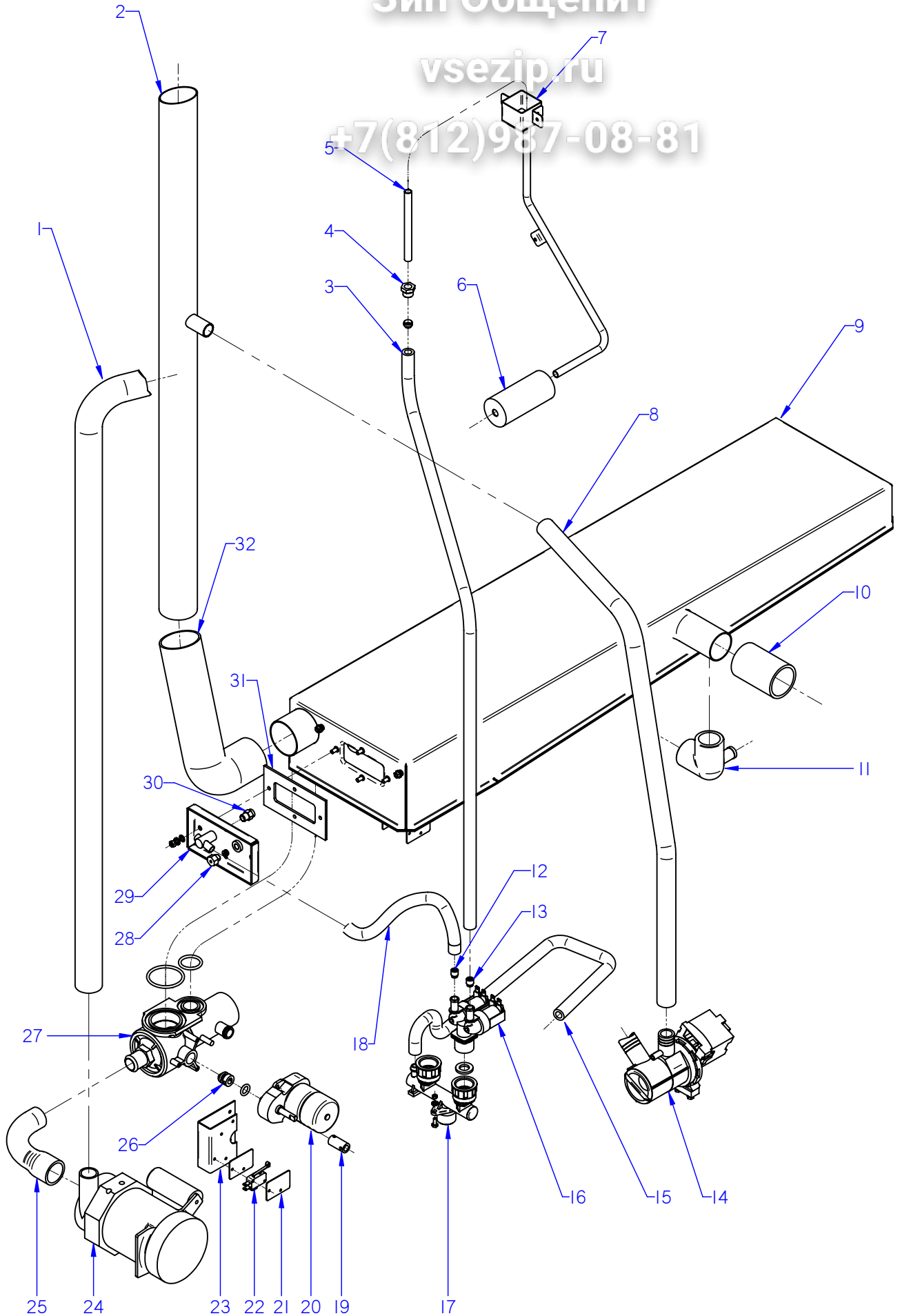

ITEM MARCADO EN COLOR = REPUESTO RECOMENDADO
COLOURED ITEM = RECOMMENDED SPARE PART

N plano	Firma	Fecha	Aparato	CIRCUITO DE AGUA	Lamina	Fagor Industrial S.Coop. FAGOR
C-2421	<i>(Signature)</i>	2009-09	HORNOS COE / VE / VPE-102		6	Oñate

MOD.	HORNOS / OVEN	ZONA	CONDUCCIONES DE AGUA / WATER PIP
-------------	----------------------	-------------	---

ITEM	CODIGO	DENOMINACION	TEXTO	COE-102	VE-102	VPE-102		
S/Nº	1100003163	KIT VALVULA DE LAVADO COMP.	WASHING VALVE KIT	-	-	1		
1	3716000000	TUBO SILICONA Tº Ø 35*27	HIGH SILICON PIPE Tº Ø 35*27	-	-	1		
	Q881305000	ABRAZADERA 25-40	CLAMP 25-40	-	-	2		
2	T355007000	CHIMENEA COMPLETA HEI 10/21	COMPLET FLUEPIPE HEI 10/21	1	-	-		
2	T325050000	CHIMENEA COMPLETA 10/21	COMPLET FLUEPIPE 10/21	-	1	1		
3	3676900000	T. GOMA NEGRA Ø17*10 INYECT.	BLACK RUBBER PIPE Ø17*10	1	1	1		
	Q881302000	ABRAZADERA 12*20	CLAMP 12-20	2	2	2		
4	R695003000	MANGÜITO CIERRE	CLOSING SLEEVE	1	1	1		
	R695004000	BICONO	BICONE	1	1	1		
5	T355001000	TUBO INYECTOR	INJECTOR PIPE	1	-	-		
5	R695033000	TUBO INYECTOR 6/11	INJECTOR PIPE	-	1	1		
6	R665025000	DISTRIBUIDOR INYECTOR	INJECTOR DISTRIBUTOR	1	-	-		
7	T355005000	INYECTOR COMPLETO HEI 1	COMPLETE INJECTOR HEI	1	-	-		
8	3715900000	TUBO SILICONA Tº Ø 26*18	HIGH SILICON PIPE Tº Ø 26*18	-	1	1		
	Q901311000	ABRAZADERA ELASTICA 26,7*28,1	ELAST. CLAMP 26,7*28,1	-	2	2		
9	T915005000	CAJA DESAGÜE LAVADO	COM. DRAINAGE BOX	1	1	-		
9	T605001000	CAJA DESAGÜE 102	COM. DRAINAGE BOX 102	1	1	-		
9	T625001000	CONJUNTO CAJA LAVADO	COMPLETE WASH BOX	-	-	1		
	Q232040000	ARANDELA A6	WASHER A.6	2	2	2		
10	3715800000	TUBO SILICONA Tº Ø 43*51	HIGH SILICON PIPE Tº Ø 43*51	1	1	1		
	Q881307000	ABRAZADERA 40*60	CLAMP 40*60	2	2	2		
11	R665080000	CODO DESAGUE	DRAINAGE L-BEND	1	1	-		
S/Nº	T815001000	CONDUCCIÓN DESAGÜE 6-10/11 E	DRAINAGE DUCT 6-10/11 E	1	1	-		
12	P443042000	REGULADOR 3 L. VERDE 254,023	REGULATOR 3 L. GREEN	1	1	1		
13	R715011000	REGULADOR 0.5L. NARANJA	REGULATOR 0.5L. ORANGE	1	1	1		
14	Z220901000	BOMBA DESAGÜE 30W	DRAINAGE PUMP 30W	-	1	1		
15	3676900000	TUBO GOMA NEGRA Ø17*10	BLACK RUBBER PIPE Ø17*10	1	1	1		
	Q881302000	ABRAZADERA 12*20	CLAMP 12-20	2	2	2		
16	P255001000	ELECTROVALVULA DOBLE	DOUBLE SOLENOID VALVE	1	1	1		
16	Z701135000	ELECTR. SIMP.220V COD.255.208	SOLENOID VALVE SIMP.220V CO	2	-	-		
16	Z611123000	ELECTR. TRIPLE COD.255.641	TRIPLE SOLENOID VALVE 255.6	-	1	1		

MOD.	HORNOS / OVEN	ZONA	CONDUCCIONES DE AGUA / WATER PIP					
ITEM	CODIGO	DENOMINACION	TEXTO	COE-102	VE-102	VPE-102		
17	T325063000	ENTRADA DE AGUA COMPLETA	COMPLETE WATER INLET	_	1	1		
17	T645006000	ENTRADA DE AGUA COMPLETA	COMPLETE WATER INLET	_	1	1		
	Q307031000	JUNTA TUBO 14X24X3	JOINT 14X24X3	_	2	2		
	Q012021000	TORNILLO EXAGONAL M4x10 A304	HEXAGONAL BOLT M4x10 A304	_	2	2		
	Q242010000	ARANDELA ABANICO A3 A.304	FAN SHAPED WASHER A.3	_	2	2		
	Q162020000	TUERCA EXAGONAL M4	HEXAGONAL NUT M.4 ^o	_	2	2		
18	3676900000	TUBO GOMA NEGRA Ø17*10	BLACK RUBBER PIPE Ø17*10	1	1	1		
	Q881302000	ABRAZADERA 12*20	CLAMP 12-20	2	2	2		
19	T330733000	CASQUILLO MOTOR MICRO	MICRO MOTOR BUSHING	_	_	1		
	Q151320000	TORNILLO ALOMADO M4X6 H.ZIN.	CURVED SCREW M4X6 H.ZIN.	_	_	2		
	Q371026000	MANGUITO SUJEC. 4X14 DIN1481	HOSE FASTENING 4X14 DIN1481	_	_	1		
	Q052032000	TORNILLO ALLEN M.5x15(+)	ALLEN HEAD SCREW M.5x15(+)	_	_	2		
20	T330711000	MOTOR VALVULA	VALVE MOTOR	_	_	1		
	Q042022000	TORNILLO AVELLANADO M4X15	COUNTERSUNK SCREW M.4x15	_	_	2		
21	R010535000	PLACA SEPARADORA	SPACER PLATE	_	_	4		
	Q032013000	TORNILLO ALOMADO M3X20	CURVED SCREW M3X20	_	_	7		
	Q221350000	TUERCA AUTOBLOCANTE M3	SELF-LOCKING NUT M3	_	_	7		
22	R010534000	INTERRUPTOR PUERTA	DOOR SWITCH	_	_	2		
23	T330713000	CHAPA SUJECCION MICROS	FASTENING PLATE MICROS	_	_	1		
23	T330754000	SOPORTE MICROS LAVADO	MICROS WASH STAND	_	_	1		
24	T360715000	MOTOBOMBA 5213E2450 FIR 50Hz	MOTOR-PUMP 5213E2450 FIR	_	_	1		
	Q232040000	ARANDELA A6	WASHER A.6	_	_	2		
	Q012043000	TORNILLO EXAGONAL M6X20	HEXAGONAL SCREW M6X20	_	_	2		
25	T330731000	GOMA VALVULA BOMBA	PUMP VALVE RUBBER	_	_	1		
	Q881304000	ABRAZADERA 20-32	CLAMP 20-32	_	_	1		
	Q881305000	ABRAZADERA 25-40	CLAMP 25-40	_	_	1		
26	T330707000	PUNTA ACOPLA MOTOR A VALVUL	CONN. POINT MOTOR TO VALVE	_	_	1		
	Q307084000	JUNTA TORICA Ø11X3.5	O-RING Ø11X3.5	_	_	1		
	Q307078000	JUNTA TORICA Ø10x3.5	O-RING Ø10x3.5	_	_	1		

Зип Общепит

vsezip.ru

+7(812)987-08-81

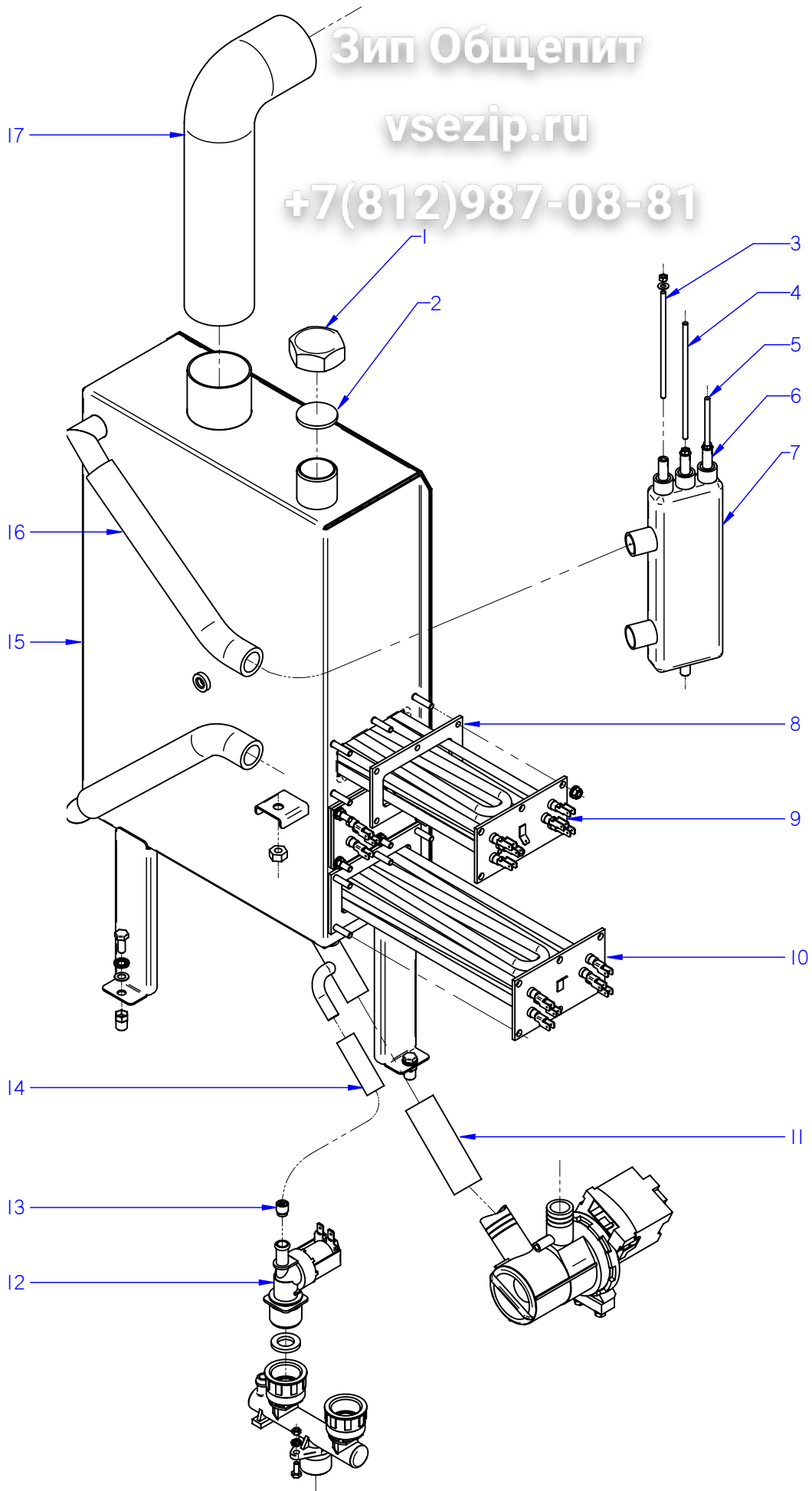

ITEM MARCADO EN COLOR = REPUESTO RECOMENDADO
COLOURED ITEM = RECOMMENDED SPARE PART

N plano	Firma	Fecha	Aparato	CIRCUITO DE VAPOR	Lamina	Fagor Industrial S.Coop. FAGOR
C-2422	<i>name Benja</i>	2009-09	HORNOS VE-102 / VPE-102		7	Oñate

MOD.		HORNOS / OVEN		ZONA		CIRCUITO DE VAPOR / STEAM CIRCUIT	
ITEM	CODIGO	DENOMINACION	TEXTO	VE-102	VPE-102		
1	R015010000	TUERCA TAPON 1"	PLUG NUT 1"	1	1		
2	R015011000	ARANDELA Ø32	WASHER Ø32	1	1		
3	R345060000	ELECTRODO ALTO	HIGH LEVEL ELECTRODE	1	1		
4	R345063000	ELECTRODO BAJO	LOW LEVEL ELECTRODE	1	1		
5	R345064000	ELECTRODO DE MASA	EARTH ELECTRODE	1	1		
	Q232020000	ARANDELA A4	FLAT WASHER A.4	3	3		
	Q162020000	TUERCA EXAGONAL M4	HEXAGONAL NUT M.4 ^o	3	3		
6	R345069000	GUIA AISLANTE	INSULATION GUIDE	3	3		
7	T325077000	BOTE DE NIVELES	LEVELS VESSEL	1	1		
7	T325079000	BOTE DE NIVELES	LEVELS VESSEL	1	1		
	Q228051000	TUERCA EXAGONAL M8 PLASTIC	HEXAGONAL NUT M8 PLASTIC	1	1		
8	T323007000	JUNTA CIERRE RESISTENCIAS	RESISTOR SEAL	3	3		
	Q232030000	ARANDELA A5	WASHER A.5	18	18		
	Q242030000	ARANDELA ABANICO A5 A.304	FAN SHAPED WASHER A.5	18	18		
	Q163030000	TUERCA EXAGONAL M5 LATON	HEXAGONAL NUT M5	18	18		
9	T323006000	RESISTENCIA 3x3000W 230V	RESISTOR 3x3000W 230V	1	1		
10	T323038000	RESISTENCIA 3x3000W 230V	RESISTOR 3x3000W 230V	2	2		
11	3715900000	TUBO SILICONA T ^o Ø 26*18	HIGH SILICON PIPE T ^o Ø 26*18	1	1		
	Q901311000	ABRAZADERA ELASTICA 26,7*28,1	ELAST. CLAMP 26,7*28,1	2	2		
12	Z701135000	ELECTROVALVUL. SIMPLE 255.208	SIMPLE SOLENOID VALVE	1	1		
13	Z601156000	REGULADOR 8L RO 254.034	REGULATOR 8L RED 254.034	1	1		
14	3676900000	T. GOMA NEGRA Ø17*10	BLACK RUBBER PIPE Ø17*10	1	1		
	Q881302000	ABRAZADERA 12*20	CLAMP 12-20	2	2		
15	1100003144	KIT GENERADOR DE VAPOR	STEAM GENERATOR KIT	1	1		
16	3715900000	TUBO SILICONA T ^o Ø 26*18	HIGH SILICON PIPE T ^o Ø 26*18	1	1		
	Q901311000	ABRAZADERA ELASTICA 26,7*28,1	ELAST. CLAMP 26,7*28,1	2	2		
17	T722608000	TUBO FLEXIBLE Ø53X360	FLEXIBLE TUBE Ø53X360	1	1		
17	12041855	TUBO FLEXIBLE Ø53X360 VARIL INC	FLEXIBLE TUBE Ø53X360	1	1		
	Q881307000	ABRAZADERA 40*60	CLAMP 40*60	2	2		

Зип Общепит

vsezip.ru

+7(812)987-08-81

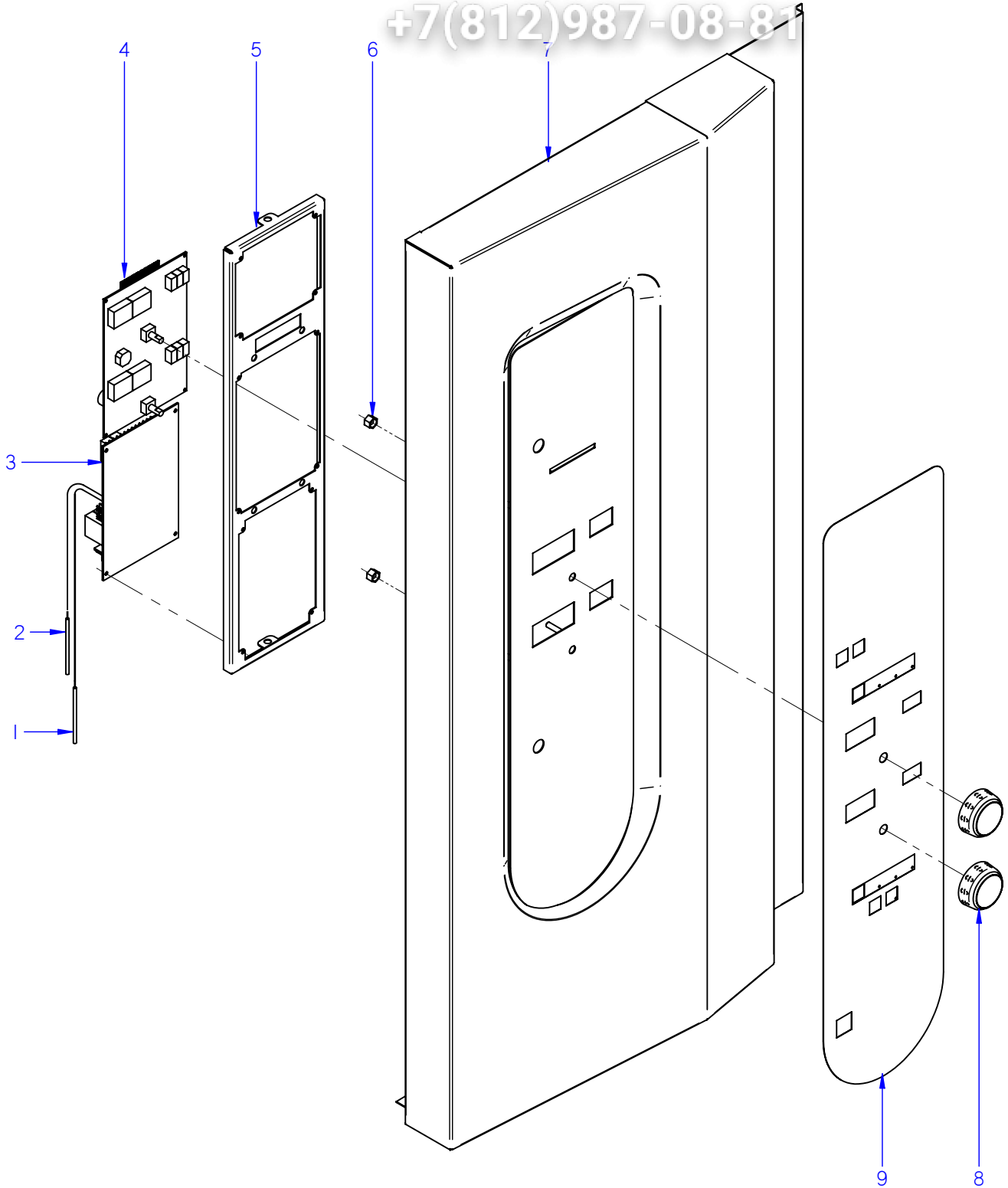

ITEM MARCADO EN COLOR = REPUESTO RECOMENDADO
COLOURED ITEM = RECOMMENDED SPARE PART

N plano	Firma	Fecha	Aparato	CONJUNTO ELECTRICO PORTAMANDOS	Lamina	Fagor Industrial S.Coop. FAGOR
C-2423	<i>(Signature)</i>	2009-09	HORNOS COE-102		8	Oñate

Зип Общепит

vsezip.ru

+7(812)987-08-81

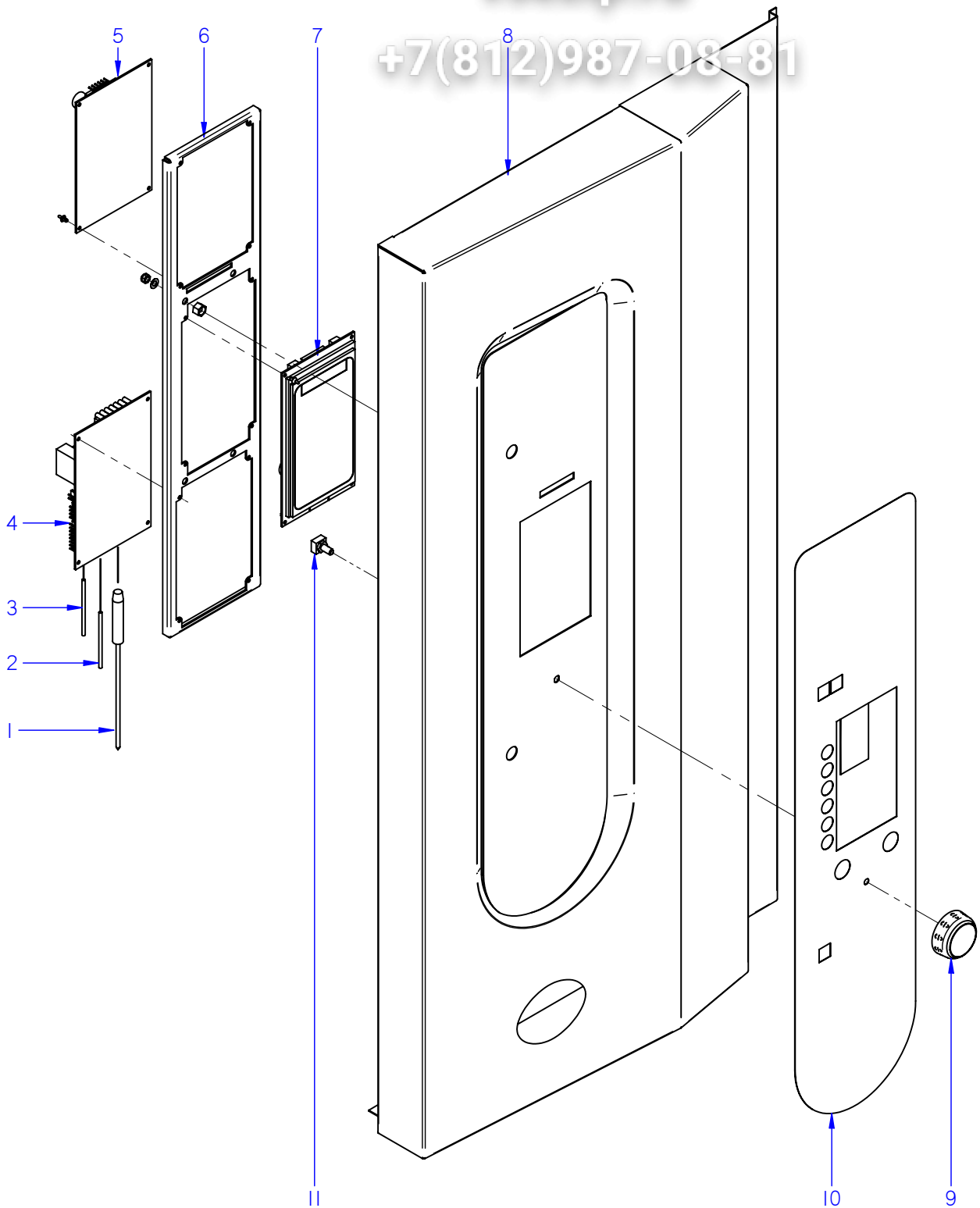

ITEM MARCADO EN COLOR = REPUESTO RECOMENDADO
COLOURED ITEM = RECOMMENDED SPARE PART

N plano	Firma	Fecha	Aparato	CONJUNTO ELECTRICO PORTAMANDOS	Lamina	Fagor Industrial S.Coop. FAGOR
C-2424	<i>(Signature)</i>	2009-09	HORNOS VE-102		9	Oñate

Зип Общепит

vsezip.ru

+7(812)987-08-81

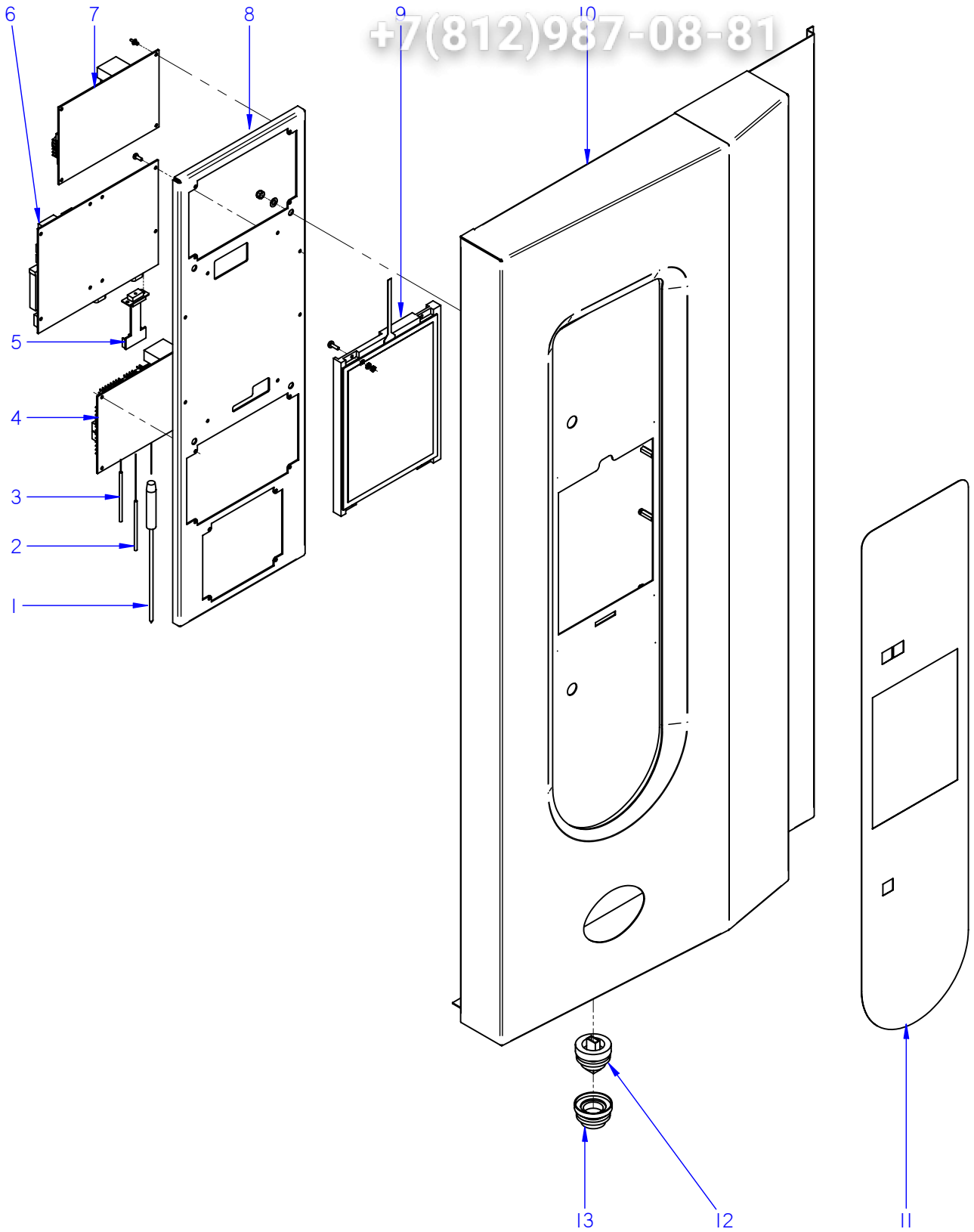

ITEM MARCADO EN COLOR = REPUESTO RECOMENDADO
COLOURED ITEM = RECOMMENDED SPARE PART

N plano	Firma	Fecha	Aparato	CONJUNTO ELECTRICO PORTAMANDOS	Lamina	Fagor Industrial S.Coop. FAGOR
C-2425	<i>(Signature)</i>	2009-09	HORNOS VPE-102		10	Oñate

APARATO / APPLIANCE		HORNOS / OVENS		ZONA / ZONE		CONJUNTO ELECTRICO PORTAMANDOS CONTROL HOLDER ELECTRIC UNIT					
ITEM	CODIGO REFERENCE	DENOMINACION	DENOMINATION	VPE-102							
1	T623006000	CONJUN. SONDA NUCLEO 5 PUNT	PROBE UNIT FOR CORE	1							
2	T323011000	CONJUN. TERMOPAR CAMARA (K)	CHAMBER THERMOCOUPLE UNI	1							
3	T323024000	CONJUN. TERMOPAR VAPOR 10/2	STEAM THERMOCOUPLE UNIT 1	2							
4	T553003000	TARJETA CONTROL DE CAMARA	CHAMBER CONTROL CARD	1							
4	12097540	CONTROL TARJETA CAM.12V AC .	CARD CONTROL 12V AC 50/60Hz	1							
	Q221026000	CLIP SUJECIÓN RÁPIDA Ø 4	RAPID CONNECT CLIP Ø 4	4							
5	T553007000	MOCHILA BMF	DONGLE BMF	1							
6	T553001000	CIRC. PORTAMANDOS GAMA ALTA	CONTROL HOLDER CIRC. HIGH	1							
	T133007000	DISTANCIADOR M3	SPACER M3	4							
	T133008000	TORNILLO AMARRE M3	ANCHORING SCREW M3	6							
	Q161310000	TUERCA EXAGONAL M3 H. ZINC,	HEXAGONAL NUT M3 H. ZINC,	6							
7	T553009000	TARJETA CONTROL CALDERA	BOILER CONTROL CARD	1							
7	T553002000	TARJETA CONTROL CALDERA	BOILER CONTROL CARD	1							
7	12097545	CONTROL TARJETA CALD. 12V AC	CARD CONTROL 12V AC 50/60Hz	1							
	Q221026000	CLIP SUJECIÓN RÁPIDA Ø 4	RAPID CONNECT CLIP Ø 4	4							
8	T652802000	SOPORTE PROGRAM HEP HGP 21	PROGRAM. SUPPORT HEP HGP	1							
8	T652804000	SOPORTE CIRCUITOS VPE VPG 21	SUPPORT CIRCUITS VPE VPG 21	1							
9	T623004000	PANTALLA TACTIL 8,4	TOUCH SCREEN 8,4	1							
9	T553010000	PLATAFORMA VISUAL PLUS	VISUAL PLUS PLATFORM	1							
	Q032011000	TORNILLO ALOMADO M3x10	CURVED SCREW M.3x10	4							
	Q232010000	ARANDELA PLANA A3 DIN 125	WASHER A3 DIN 125	4							
	Q242010000	ARANDELA ABANICO A3 A.304	FAN SHAPED WASHER A.3	4							
	Q161310000	TUERCA EXAGONAL M3 H. ZINC,	HEXAGONAL NUT M3 H. ZINC,	4							
10	T622803000	PANEL PORTAMANDOS 10-21 HEP	CONTROL PANEL 10-21 HEP	1							
10	T622805000	PANEL PORTAMANDOS VPE-102	CONTROL PANEL VPE-102	1							
11	T623003000	SERIGRAFIA HEP 21	SERIGRAPHY HEP 21	1							
11	T623007000	SERIGRAFIA VISUAL PLUS	SERIGRAPHY VISUAL PLUS	1							
11	T623016000	SERIGRAFIA VISUAL PLUS	SERIGRAPHY VISUAL PLUS	1							
12	T723006000	CONECTOR USB VISUAL PLUS	VISUAL PLUS USB CONNECTOR	1							
13	T723007000	TAPA USB VISUAL PLUS	VISUAL PLUS USB COVER	1							

Зип Общепит

vsezip.ru

+7(812)987-08-81

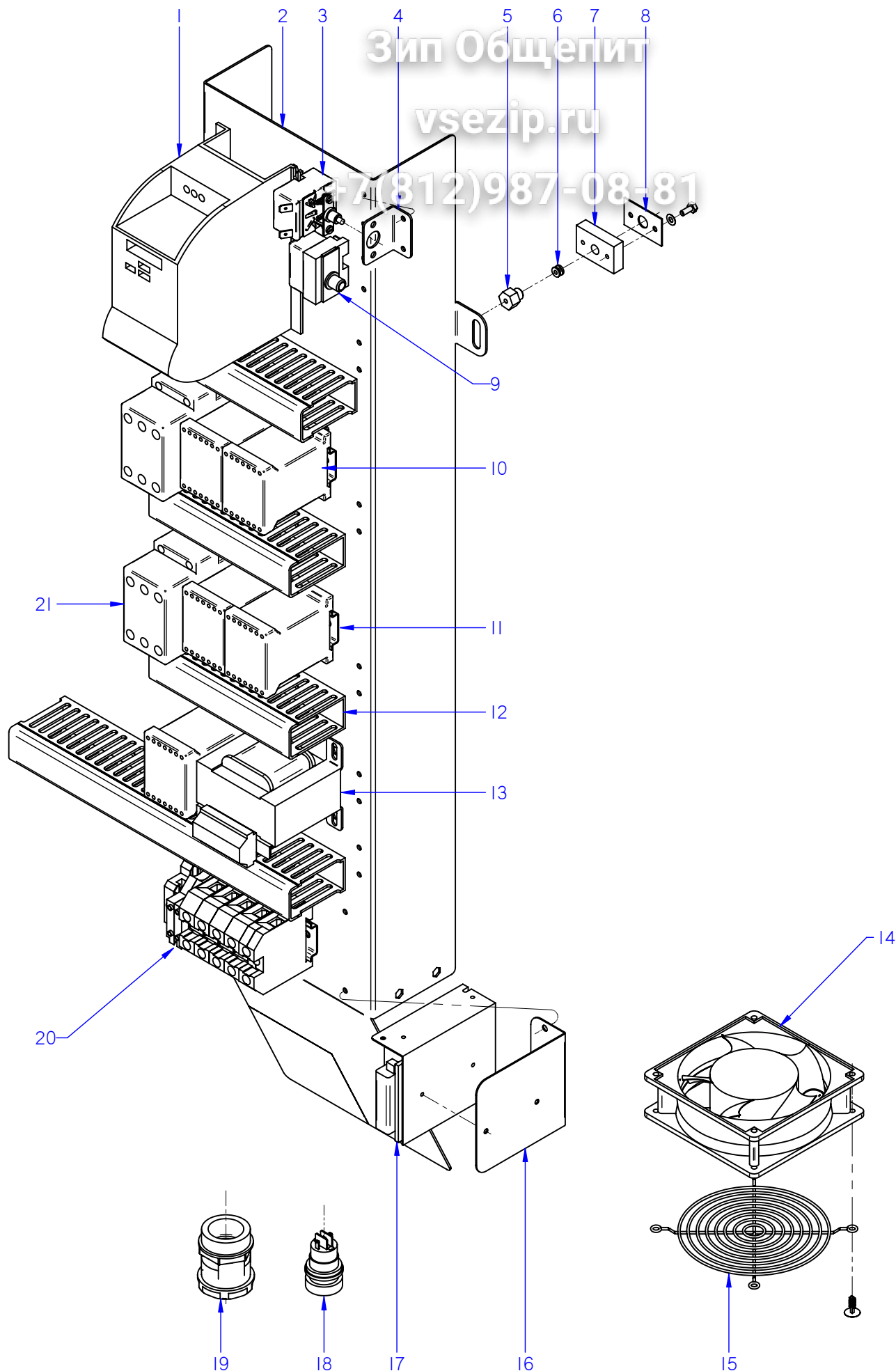

ITEM MARCADO EN COLOR = REPUESTO RECOMENDADO
COLOURED ITEM = RECOMMENDED SPARE PART

N plano	Firma	Fecha	Aparato	CUADRO ELECTRICO	Lamina	Fagor Industrial S.Coop. FAGOR
C-2426	<i>name (ben)</i>	2009-09	HORNOS COE / VE / VPE-102		11	Oñate

MOD.		HORNOS / OVEN		ZONA		CUADRO ELECTRICO / ELECTRIC PANE	
ITEM	CODIGO	DENOMINACION	TEXTO	COE-102	VE-102	VPE-102	
1	T323037000	VARIADOR FRECUENCIA SIE 0,37	FREQUENCY VARIATOR SIE 0.37	1	1	1	
	Q232020000	ARANDELA A4	WASHER A.5	2	2	2	
	Q242020000	ARANDELA ABANICO A4 A.304	FAN SHAPED WASHER A.4	2	2	2	
	Q032021000	TORNILLO ALOMADO M4X10	CURVED SCREW M.4x10	2	2	2	
2	T613007000	CHAPA CUADRO ELEC 10/21	SQUARE PLATE	1	1	1	
2	T613009000	CHAPA CUADRO ELEC 102E	SQUARE PLATE 102E	1	1	1	
	Q221341000	REMACHE EXAGONAL M4	HEXAGONAL RIVET M.4	6	6	6	
	Q221342000	REMACHE EXAGONAL M5	HEXAGONAL RIVET M.5	2	2	2	
	Q232030000	ARANDELA A5	WASHER A.5	2	2	2	
	Q012032000	TORNILLO EXAGONAL M5x15 A304	HEXAGONAL SCREW M.5x15	2	2	2	
	Q232040000	ARANDELA A6	WASHER A.6	1	1	1	
	Q242040000	ARANDELA ABANICO A6 A.304	FAN SHAPED WASHER A.6	1	1	1	
	Q162040000	TUERCA EXAGONAL M6	HEXAGONAL NUT M.6	1	1	1	
3	T303009000	TERMOSTATO LIMITADOR	THERMOSTAT LIMITER	1	1	1	
4	R343039000	SOPORTE TERMOS VAPOR	THERMOSTAT SUPPORT	1	2	2	
	Q412002000	REMACHE AVINOX Ø4x10MM	TUBULAR RIVET 4x7,5	2	4	4	
5	R662629000	RACORD CIERRE SONDA	PROBE CLOSING ADAPTOR	2	2	2	
S/Nº	R662662000	JUNTA CIERRE BULBO LIMITADOR	BULB LIMITER CLOSING SEAL	1	1	1	
6	R662652000	BICONO CIERRE SONDA	PROBE CLOSING BICONE	2	2	2	
7	T112625000	BASE CIERRE SONDA	FIXING CORE PROBE	2	2	2	
8	R692812000	JUNTA PASAMUROS SIMPLE	FEEDTHROUGH SEAL	2	2	2	
	Q232020000	ARANDELA A4	WASHER A.4	4	4	4	
	Q012021000	TORNILLO EXAGONAL M4X10	HEXAGONAL BOLT M4X10	4	4	4	
9	Z953035000	TERMOSTATO LIMITADOR AVISO	LIMITER THERMOSTAT WARNIN	-	1	1	
	Z953041000	TUERCA M.10x1 EGO 00.00600.075	NUT M.10x1 EGO 00.00600.075	1	2	2	
10	Z203050000	CONTAC. SIRIUS 3R 230V.50-60	SIRIUS 3R 230V.50-60 CONTAC.	5	5	5	
10	Z213007000	CONTACTOR 230V.50-60	230V.50-60 CONTACTOR	1	1	1	
10	X183011000	CON.3RT1024-1AN20 230V 50H	3RT1024-1AN20 230V 50H CONT	4	4	4	
11	Z123018000	GUIA CONTACTOR L-55	CONTACTOR GUIDE L-55	1	1	1	
	Z103084000	GUIA CONTACTOR L-138	CONTACTOR GUIDE L-138	2	2	2	
	R663055000	GUIA CONTACTOR L-120	CONTACTOR GUIDE L=120	1	1	1	

MOD.	HORNOS / OVEN	ZONA	CUADRO ELECTRICO / ELECTRIC PANEL					
ITEM	CODIGO	DENOMINACION	TEXTO	COE-102	VE-102	VPE-102		
12	3715520000	CANALETA UNEX 60.30.77 / 0.12	PIPING UNEX 60.30.77 / 0.12	5	5	5		
	Q412002000	REMACHE AVINOX Ø4x10MM	TUBULAR RIVET 4x7,5	22	26	26		
13	R503005000	TRANSFORMADOR 230/12-0-12,0-1	TRANSFORMER 230/12-0-12,0-1	1	1	—		
13	R503005000	TRANSFORMADOR 230/12-0-12,0-1	TRANSFORMER 230/12-0-12,0-1	—	—	1		
13	T853002000	TRANSFORMADOR 12-0-12-0,24-0	TRANSFORMER 12-0-12-0,24-0	—	—	1		
14	Z103066000	VENTILADOR 230V.50-60HZ	FAN 230V 50/60HZ	2	2	2		
15	T113015000	PROTECCION VENTILADOR	FAN PROTECTION	1	1	1		
	Q418022000	REMACHE NYLON 4x15	TUBULAR RIVET NYLON 4x15	4	4	4		
	Q031322000	TORNILLO ALOMADO M4x15	CURVED SCREW M.4x15	4	4	4		
	Q232020000	ARANDELA A4	WASHER A.4	4	4	4		
	Q242020000	ARANDELA ABANICO A4 A.304	FAN SHAPED WASHER A.4	4	4	4		
	Q162020000	TUERCA EXAGONAL M4	HEXAGONAL NUT M.4	4	4	4		
16	T553008000	SOPORTE ALIMENTACION	POWER SUPPLY SUPPORT	—	—	1		
	Q232020000	ARANDELA A4	WASHER A.4	—	—	4		
	Q242020000	ARANDELA ABANICO A4 A.304	FAN SHAPED WASHER A.4	—	—	4		
	Q032021000	TORNILLO ALOMADO M4x10	CURVED SCREW M.4x10	—	—	4		
17	T553005000	ALIMENT PORTAMAN VISUAL PLUS	VISUAL PLUS CONTROL HOLDER	—	—	1		
18	T723009000	PULSADOR SERIE MICRO	MICRO SWITCH SERIES	—	—	1		
19	R033002000	PRENSA ESTOPAS	STUFFING BOX	1	1	1		
	R033025000	CONTRATUERCA (GAES)	COUNTERNUT (GAES)	1	1	1		
20	R263003000	BORNA PASO 35MM	GREY PHASE 35 TERMINAL	3	3	3		
	Z103035000	BORNA TIERRA 35MM	EARTH TERMINAL 35mm	1	1	1		
	R673010000	BORNA PASO AZUL 35MM	NEUTRAL TERMINAL 35 BLUE	1	1	1		
	R073005000	BORNA PORTAFUSIBLES	FUSE HOLDER TERMINAL	2	2	2		
	Z263303000	TOPE FINAL	END BUFFER	1	1	1		
21	X183011000	CONTAC.3RT1024-1AN20 230V 50H	CON.3RT1024-1AN20 230V 50H	—	2	2		
S/Nº	Z233012000	CONDENSADOR ANTIPARASITARIO	ANTIPARASITIC CONDENSER	2	3	3		

MOD.		HORNOS / OVEN		ZONA		VARIOS / MISCELLANEOUS	
ITEM	CODIGO	DENOMINACION	TEXTO	COE-102	VE-102	VPE-102	
	T906501000	MANUAL DE INSTRUCCIONES COE	INSTRUCTIO. BROCHURE COE	1	-	-	
	T916501000	MANUAL DE INSTRUCC. VE	INSTRUC. BROCHURE VE SPA	-	1	-	
	T926501000	MANUAL DE INSTRUCC. VPE	INSTRUC. BROCHURE VPE SPA	-	-	1	
	T326507000	MANUAL DE INSTRUCC. VPE ING.	INSTRUC. BROCHURE VPE ENG	1	1	1	
	T326506000	MANUAL DE INSTRUCC. VPE FRA.	INSTRUC. BROCHURE VPE FRE	1	1	1	
	T326501000	MANUAL DE INSTRUCC. VPE ALE.	INSTRUC. BROCHURE VPE GER	1	1	1	
	T326508000	MANUAL DE INSTRUCC. VPE ITA.	INSTRUC. BROCHURE VPE ITA	1	1	1	
	T603001000	ESQUEMA TEORICO COE 102	THEORET. DIAGRAM COE 102	1	-	-	
	T613001000	ESQUEMA TEORICO VE 102	THEORET. DIAGRAM VE 102	-	1	-	
	T623001000	ESQUEMA TEORICO VPE 102	THEORET. DIAGRAM VPE 102	-	-	1	
	T923015000	ESQUEMA TEORICO COE VE VPE	THEOR. DIAGRAM COE VE VPE	1	1	1	
	T603002000	PLANO DE MONTAJE COE 102	ASSEMBLY PLAN COE 102	1	-	-	
	T613002000	PLANO DE MONTAJE VE 102	ASSEMBLY PLAN VE 102	-	1	-	
	T623002000	PLANO DE MONTAJE VPE 102	ASSEMBLY PLAN VPE 102	-	-	1	
	T623015000	PLANO DE MONTAJE VPE 102	ASSEMBLY PLAN VPE 102	1	1	1	
	T303031000	CABLEADO LUZ INTERIOR	INTERIOR LIGHT WIRING	1	1	1	
	T903006000	CABLEADO COMUNICACIÓN BMF	COMMUNICATION WIRING BMF	1	2	2	
	T923016000	CABLEADO BMF	WIRING BMF	1	2	2	
	T603003000	INSTAL. ELEC. CONCEPT 10/21	ELEC. INSTAL. CONCEPT 10/21	1	-	-	
	T603011000	INSTAL. ELEC. COE-102	ELEC. INSTAL. COE-102	1	-	-	
	T613003000	INSTAL. ELEC. VISUAL E 10/21	ELEC. INSTALL. VISUAL E 10/21	-	1	1	
	T613010000	INSTAL. ELEC. VISUAL VPE-102	ELEC. INSTALL. VISUAL VPE-102	-	1	1	
	T603004000	CABLEA. FUERZA CONCEPT 10/21	POWER WIRE . CONCEPT 10/21	1	-	-	
	T603009000	CABLEA. FUERZA COE-102	POWER WIRE . COE-102	1	-	-	
	T613004000	CABLEADO FUERZA VISUAL E 10/21	POWER WIRE . VISUAL E 10/21	-	1	1	
	T613011000	CABLEADO FUERZA VISUAL VE-102	POWER WIRE . VISUAL VE-102	-	1	1	
	T603005000	CABLEADO RESI. CONCEPT 10/21	RESISTOR WIRING CONCEPT	1	-	-	
	T603010000	CABLEADO RESI. COE-102	RESISTOR WIRING COE-102	1	-	-	
	T613005000	CABLEADO RESIS. VISUAL E 10/21	RESISTOR WIRING VISUAL	-	1	1	
	T613012000	CABLEADO RESIS. VISUAL VE-102	RESISTOR WIRING VE-102	-	1	1	
	T913006000	CAB CIRCUIT PORTAMANDOS VIS.	VIS. CONTROL HOLDER CIRCUIT	-	1	-	

СОЕ 102

Зип Общепит

3N-50/60Hz 380/415V

vsezip.ru

+7(812)987-08-81

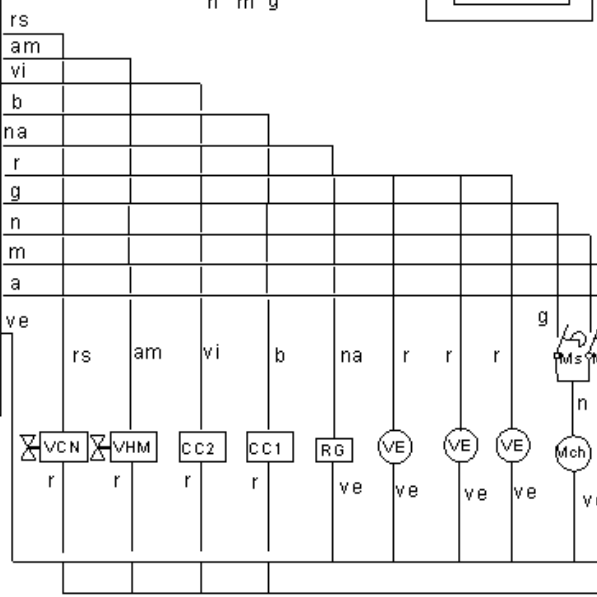
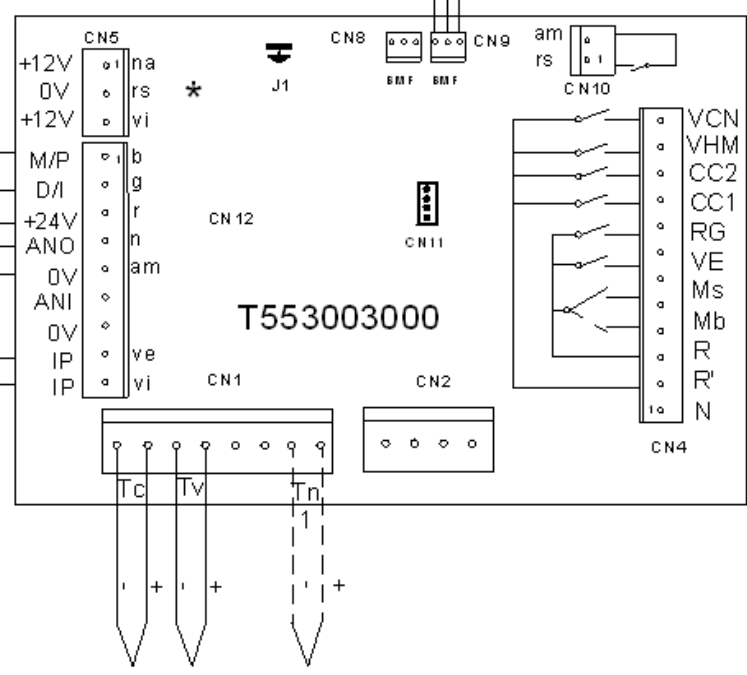
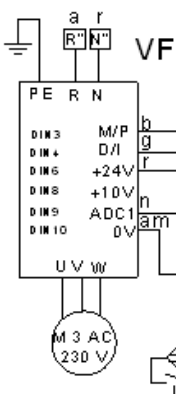
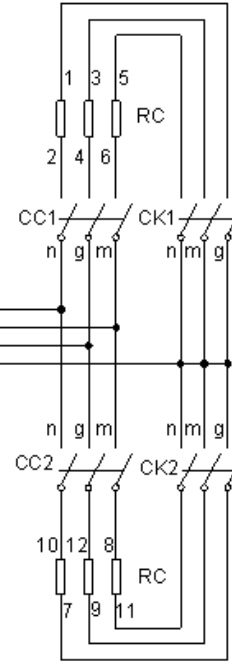
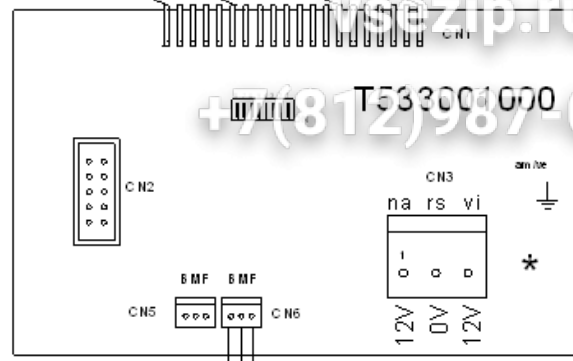

VE 102

Зип-Общепит

vsezip.ru

+7(812)987-08-81

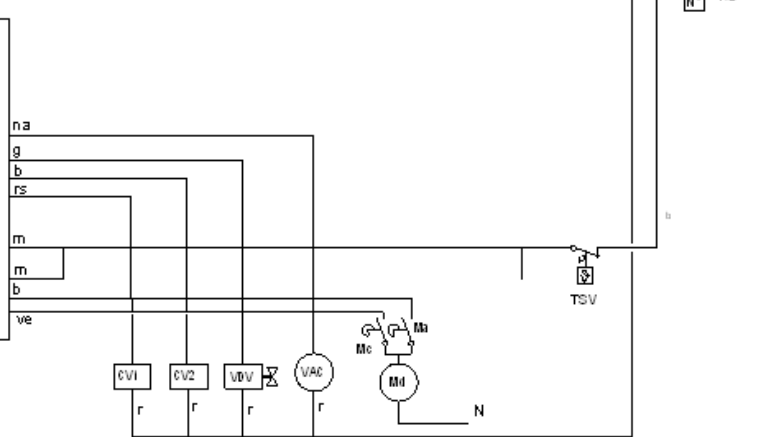
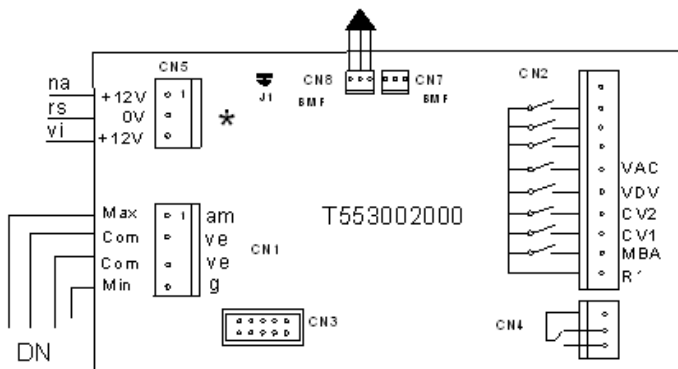
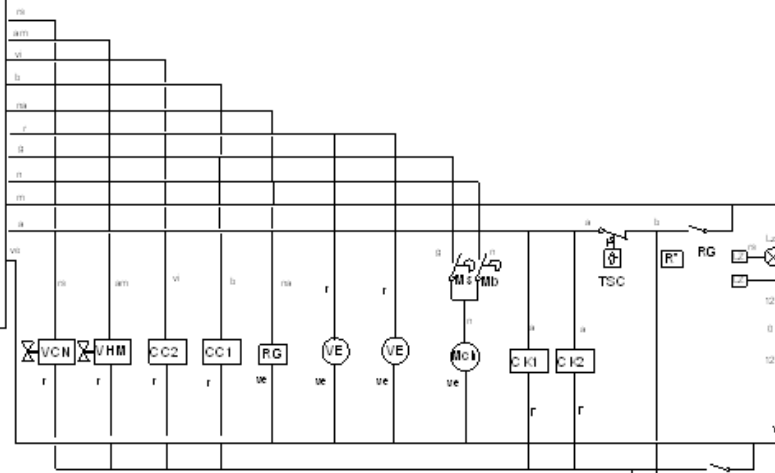
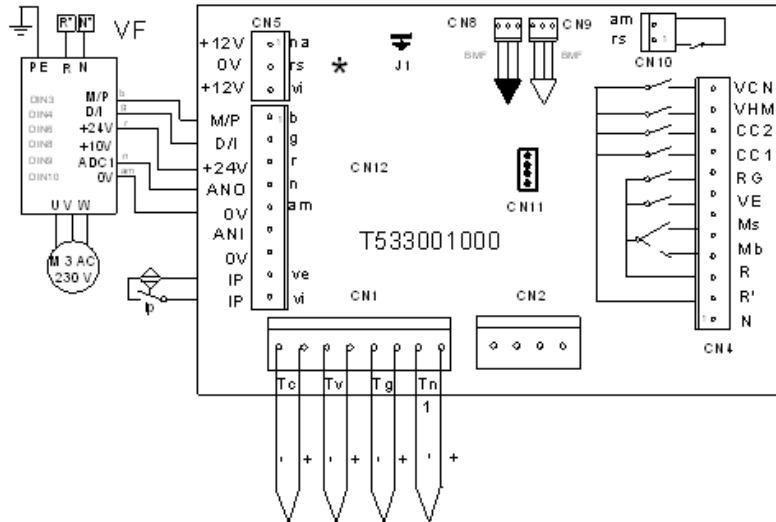
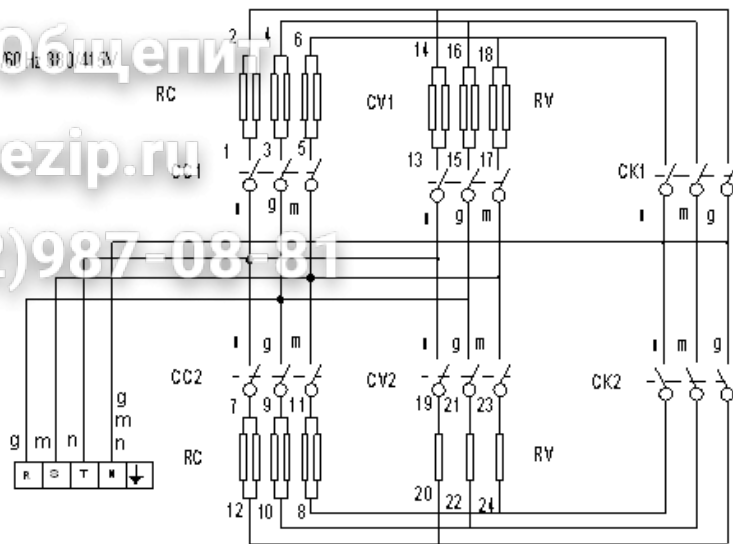
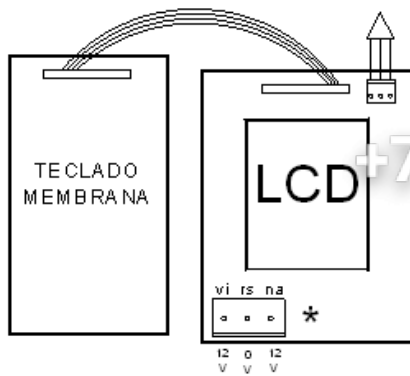

Зип Общепит

vsezip.ru

+7(812)987-08-81

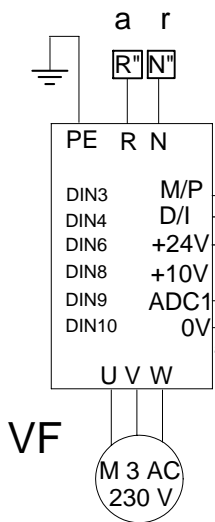
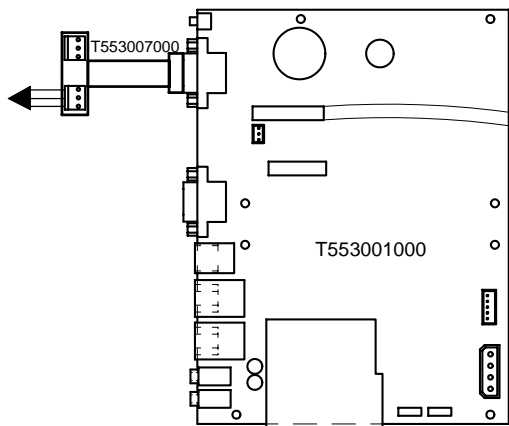

VPE 102

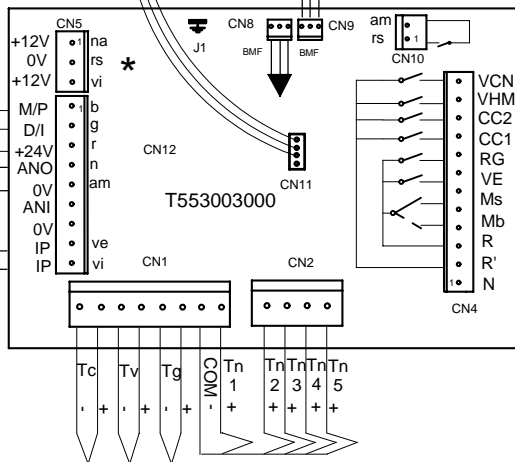
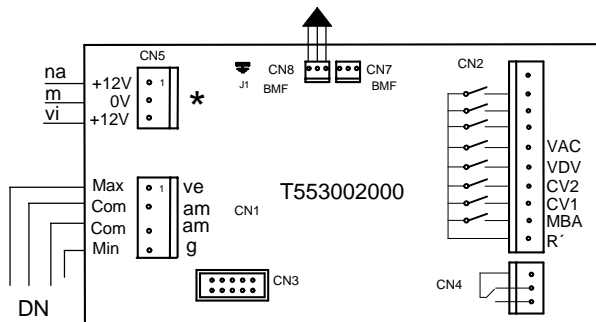

3N-50/60Hz 380/415V

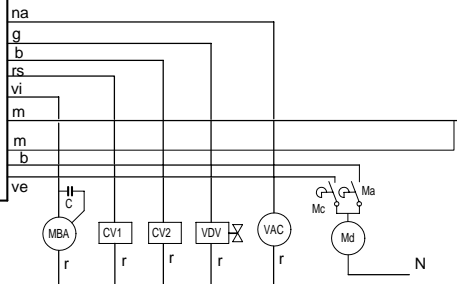
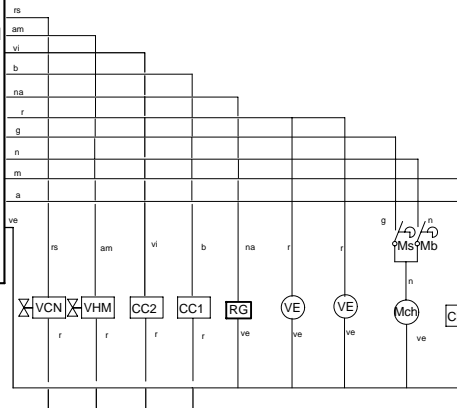
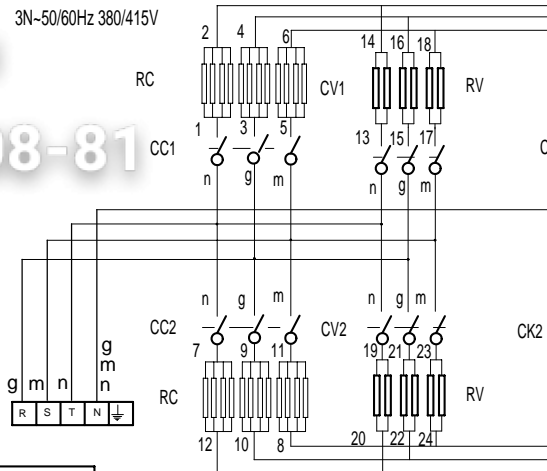

Зип ОбщениТ
vsezip.ru

+7(812)987-08-81



Eskema teorikoa	T603001
1	T603003
2	T603006
3	T603004
4	T603005
5	T303031
6	T903006

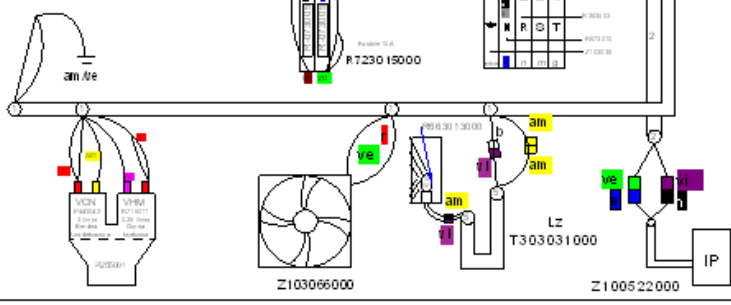
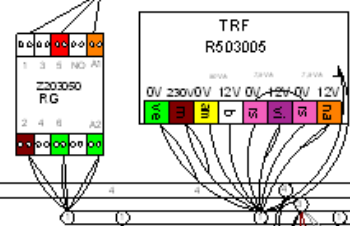
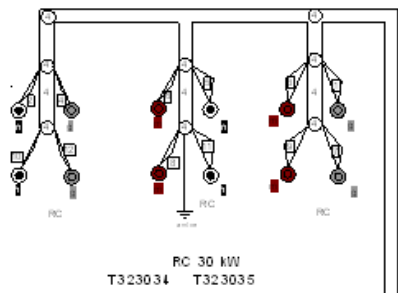
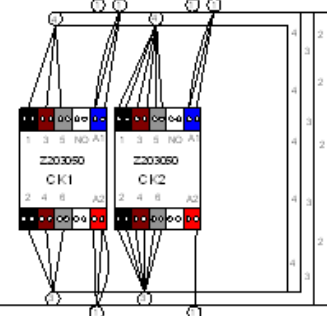
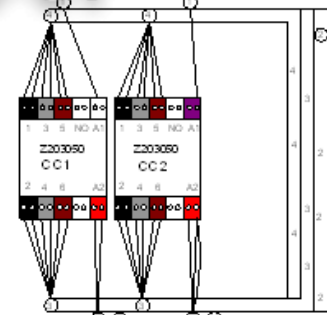
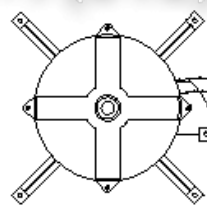

-
Zs, 70'
Zs, 70'
-
-
-
-
-
-

Менеджер
Продукция
Специалист
Служба

Зип ОбщениТ

vsezip.ru

+7(812)987-08-81

Eskema teorikoa	T61 3001
1	T613003
2	T603006
3	T613004
4	T613005
5	T303031
6	T903006
7	T913006
8	T903006

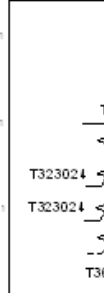
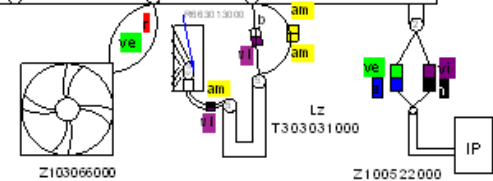
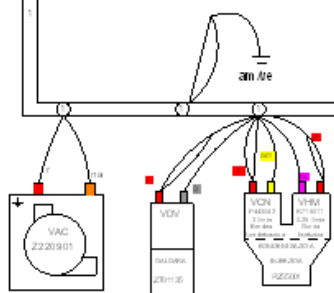
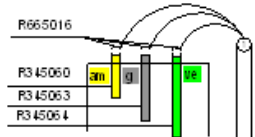
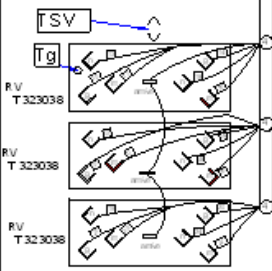
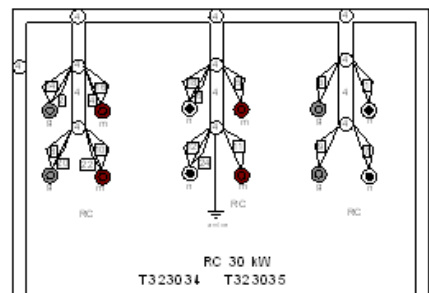
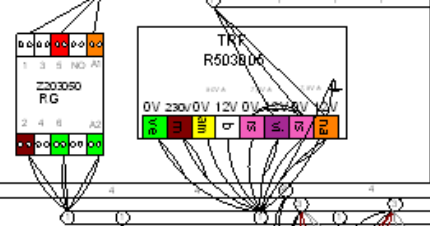
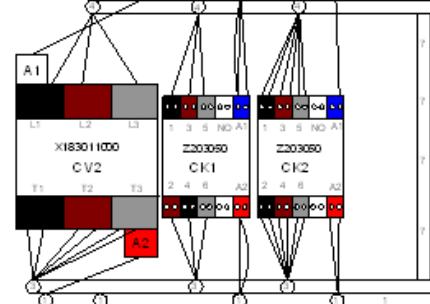
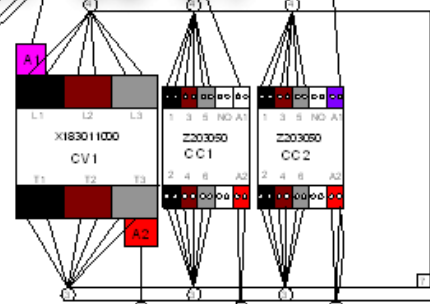
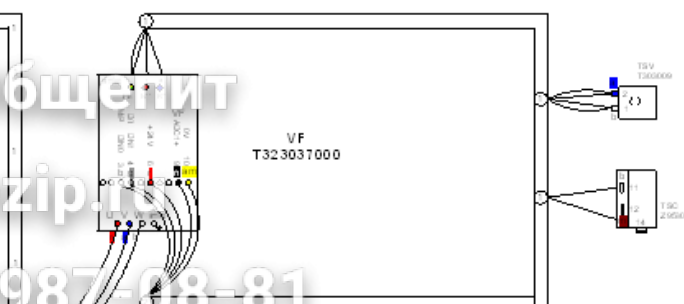
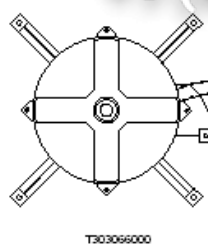
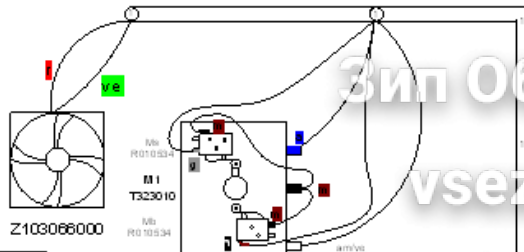

№	Имената	Продуктите	Сградите	Сградите	Сградите
1					
2					
3					
4					
5					
6					
7					
8					

3 ~ 400V

Mod. 101	RC2=3x3KW	Mod. 061, 101	RC1=3x3KW
Mod. 201	RC2=3x6KW	Mod. 201, 102	RC1=3x6KW
Mod. 102	RC2=3x3KW	Mod. 102	RC1=3x3KW
Mod. 202	RC2=3x3KW	Mod. 202	RC1=3x3KW

Mod.	Mod. 061, 101	RV1=3x3KW
	Mod. 201, 102	RV1=6x3KW
	Mod. 202	RV1=9x3KW
VPE, VE,	Mod. 101, 102, 201, 202	Fz=3x3V
	Mod. 202	Fz=9x3V

VPE 06 1, VPE 10 1, VPE
VE 06 1, VE 10 1, VE
COE 06 1, COE 10 1, COE

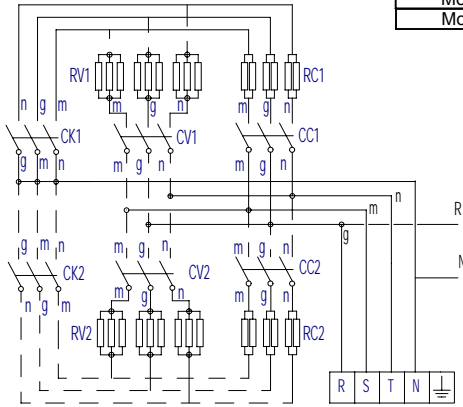

+7(812)98708-81

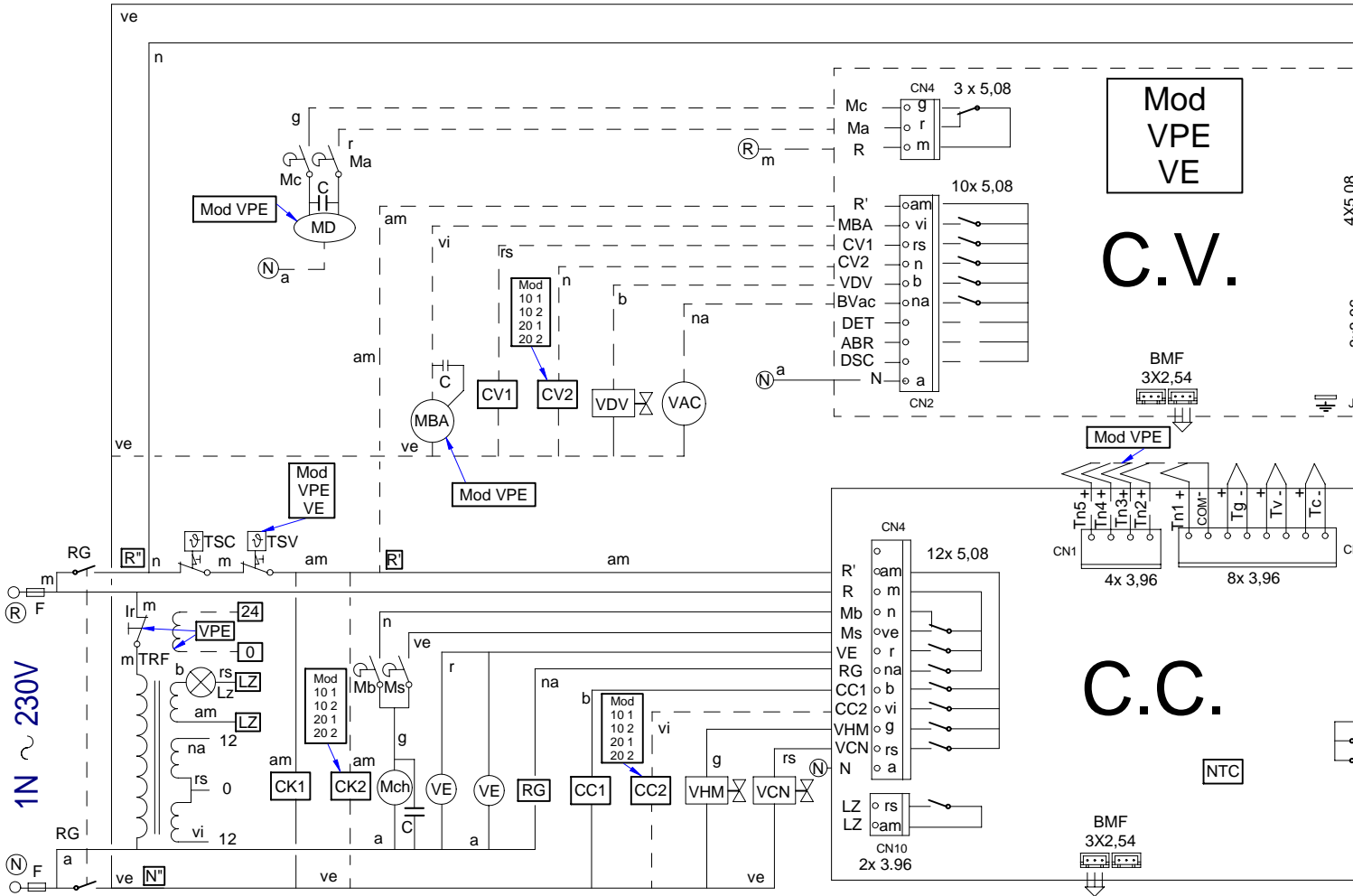
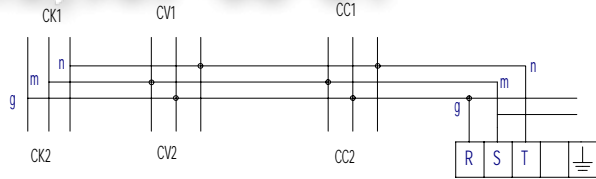

Зип Објект
 VSE-СТУЛО
 +7(812)987-0888

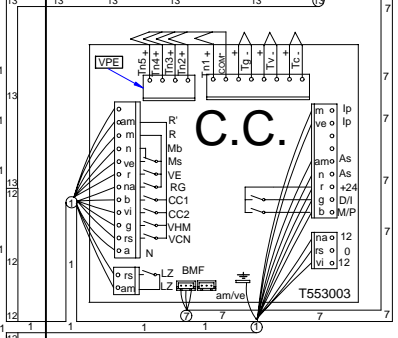
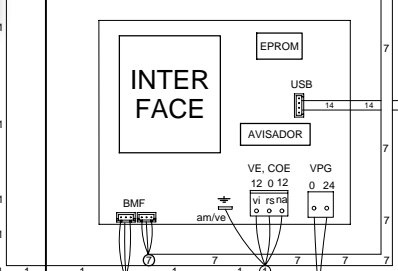
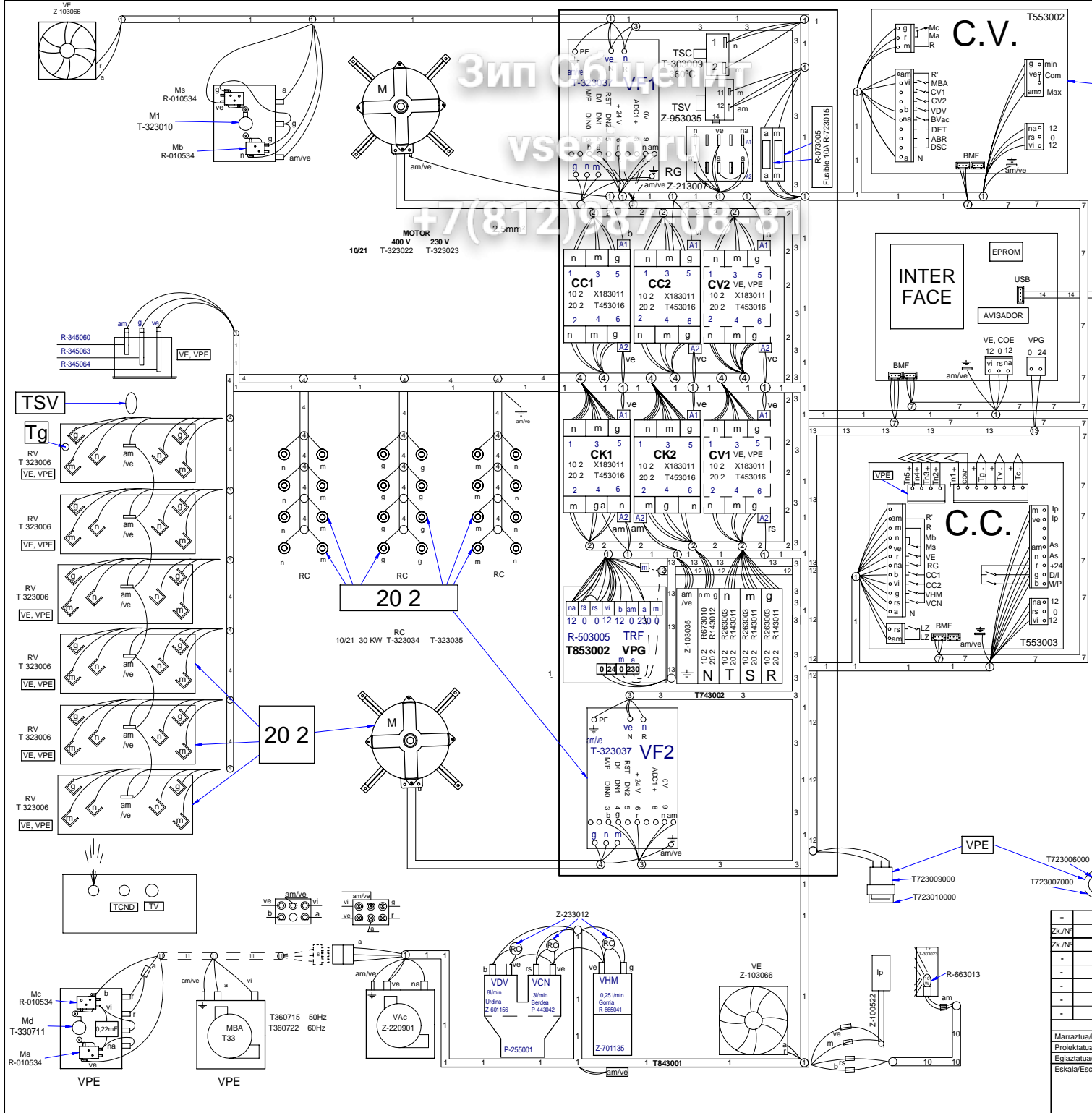

-	P
Zk./N°	
Zk./N°	
-	
-	
-	
-	
-	
-	
Marratzua/D	
Proiektatua/I	
Egiaztatua/C	
Eskala/Esca	

	ESPAÑOL	FRANÇAIS	ENGLISH	DEUTSCH
BEC	Bujía Encendido Cámara	Bougie Allumage Chambre	Chamber Spark Plug	Zündkerze Einschalten Ga
BEV	Bujía Encendido Caldera	Bougie Allumage Chaudière	Boiler Spark Plug	Zündkerze Einschalten Bo
C.C.	Control Camara	Contrôle Chambre	Chamber Control	Steuerung Garraum
C.E.C	Control Combustión Cámara	Contrôle Combustion Chambre	Chamber Combustion Control	Steuerung Verbrennung Ga
C.E.V	Control Combustión Caldera	Contrôle Combustion Chaudière	Boiler Combustion Control	Steuerung Verbrennung Bo
C.G.	Control Gas	Contrôle Gaz	Control Gas	Steuern Sie Gas
C.V.	Control Caldera	Contrôle Chaudière	Boiler Control	Steuerung Boiler
CC1, CC2	Contactador Resistencia Cámara	Contacteur Élément Chauffant Chambre	Chamber Heating Element Contactor	Schütz Heizwiderstand Ga
CK1, CK2	Contactador General Calentamiento	Relais Élément Chauffant	Heating Element Relay	Relais Heizwiderstand
CV1, CV2	Contactador Resistencias Caldera	Contacteur Élément Chauffant Chaudière	Boiler Heating Element Contactor	Schütz Heizwiderstand Bo
DEC	Detector Llama Cámara	Détecteur Flamme Chambre	Chamber Flame Detector	Flammendetektor Garraum
DEV	Detector Llama Caldera	Détecteur Flamme Chaudière	Boiler Flame Detector	Flammendetektor Boiler
DN	Detector Nivel Caldera	Détecteur Niveau Chaudière	Boiler Level Detector	Pegeldetektor Boiler
F	Fusibles	Fusibles	Fuses	Sicherungen
FI	Filtro Interferencias	Filtre Interférences	Interference Filter	Störungsfilter
FM	Térmico Motor	Thermique Moteur	Thermal Engine	Thermoschalter Motor
GV1, GV2	Electro válvula Gas Cámara	Électrovanne Gaz Chambre	Chamber Gas Solenoid Valve	Elektroventil Gas Garraum
GV3, GV4	Electro válvula Gas Caldera	Électrovanne Gaz Chaudière	Boiler Gas Solenoid Valve	Elektroventil Gas Boiler
Ip	Interruptor Seguridad Puerta	Interrupteur Sécurité Porte	Door Safety Switch	Sicherheitsschalter Tür
Lz	Luz Interior	Éclairage Intérieur	Inner Light	Innenbeleuchtung
M, M2	Motor Turbina	Moteur Turbine	Turbine Engine	Motor Turbine
Ma	Interruptor Micro Abierto	Microrupteur Ouvert	Open Microswitch	Mikroschalter Geöffnet
Mb	Interruptor Micro Bajada	Microrupteur Descente	Drop Microswitch	Mikroschalter Senken
Mc	Interruptor Micro Cerrado	Microrupteur Fermé	Closed Microswitch	Mikroschalter Geschlossen
Mch	Motor Chimenea	Moteur Cheminée	Stack Engine	Motor Abluftkamin
MD	Motor Desague	Moteur évacuation	Drain Engine	Motor Abfluss
Ms	Interruptor Micro Subida	Microrupteur Montée	Rise Microswitch	Mikroschalter Heben
PF	Potenciómetro Selector Funciones	Potentiomètre Sélecteur Fonctions	Functions Selector Potentiometer	Potentiometer Funktionsw
RC	Resistencias Cámara	Éléments Chauffants Chambre	Chamber Heating Element	Heizwiderstände Garraum
RG	Rele General	Relais Général	Main Relay	Hauptrelais
RV	Resistencias Caldera	Éléments Chauffants Chaudière	Boiler Heating Element	Heizwiderstände Boiler
Tc	Sonda Cámara	Sonde Chambre	Chamber Probe	Sonde Garraum
TCN	Termostato Condensación	Thermostat Condensation	Condensation Thermostat	Thermostat Kondensierung
Tg	Sonda Caldera	Sonde Chaudière	Boiler Probe	Sonde Boiler
Tn	Sonda Núcleo	Sonde Noyau	Core Probe	Kerntemperaturmesssonde
TRF	Transformador	Transformateur	Transformer	Transformator
TSC	Termostato Seguridad Cámara	Thermostat Sécurité Chambre	Chamber Safety Thermostat	Sicherheitsthermostat Gar
TSV	Termostato Seguridad Caldera	Thermostat Sécurité Chaudière	Boiler Safety Thermostat	Sicherheitsthermostat Boi
Tv	Sonda Vapor	Sonde Vapeur	Steam Probe	Sonde Dampf
VAC	Bomba Vaciado	Pompe Vidange	Vacuum Pump	Ablasspumpe
MBA	Moto Bomba Aclarado	Pompe Rinçage	Rinsing Pump	Pumpe Ausspülen
VC1, VC2	Ventilador Soplante Camara	Ventilateur Soufflant	Blowing Fan	Ventilator Gebläse
VCN	Electro válvula Condensación	Électrovanne Condensation	Condensation Solenoid Valve	Elektroventil Kondensierun
VDV	Electro válvula Llenado Caldera	Électrovanne Remplissage Chaudière	Chamber Filling Solenoid Valve	Elektroventil Füllung Boiler
VE	Ventilador Cuadro Eléctrico	Ventilateur Tableau Électrique	Fan Switchboard	Ventilator Elektrotafel
VF1, VF2	Variador de Frecuencia	Variateur Vitesse	Speed Variator	Geschwindigkeitsregler
VHM	Electro válvula Humidificador	Électrovanne Humidificateur	Humidifier Solenoid Valve	Elektroventil Befeuchtungs
Vv	Ventilador Soplante Caldera	Ventilateur soufflement chaudière	Boiler Blowing Fan	Durchbrennenventilator zur
	COLORES	COULEURS	COLOUR	FARBEN
a	Azul	Bleu	Blue	Blau
am	Amarillo	Jaune	Yellow	Gelb
am/ve	Amarillo/verde	Jaune / vert	Yellow / green	Gelb/grün
b	Blanco	Blanc	White	Weiß
g	Gris	Gris	Grey	Grau
m	Marrón	Marron	Brown	Braun
n	Negro	Noir	Black	Schwarz
na	Naranja	Orange	Orange	Orange
r	Rojo	Rouge	Red	Rot
rs	Rosa	Rose	Pink	Rosa
ve	Verde	Vert	Green	Grün
vi	Violeta	Violet	Purple	Violett