

TDE550 & TDE650 SERVICE PARTS

This parts list contains the service parts and wiring diagrams for this model. Check the model number of the machine requiring the parts to be sure that this is the correct parts list.

TDE550s & TDE650s have been made in 115 volt, 60 Hz and 230 volt 50 Hz.

Model numbers for the 115 volt models include:

TDE550AE-1A and TDE550WE-1A

TDE650AE-1A and TDE650WE-1A

Model numbers for the 230 volt models include:

TDE550AE-6A and TDE550WE-6A.

TDE650AE-6A and TDE650WE-6A.

Note: The liquid line filter drier listed in this parts list is designed for this refrigeration system. Premature failure may result if the wrong drier is used.

TABLE OF CONTENTS

Cabinet Assembly	Page 2
Air Cooled Refrigeration	Page 4
Water Cooled Refrigeration	Page 5
Ice Dispensing	Page 6
Evaporator	Page 7
Gearmotor Assembly	Page 8
Control Box	Page 9
Water System	Page 10
Wiring Diagrams	Page 11

TDE550 & TDE650 SERVICE PARTS

Cabinet

vsezip.ru

+7(812)987-08-81

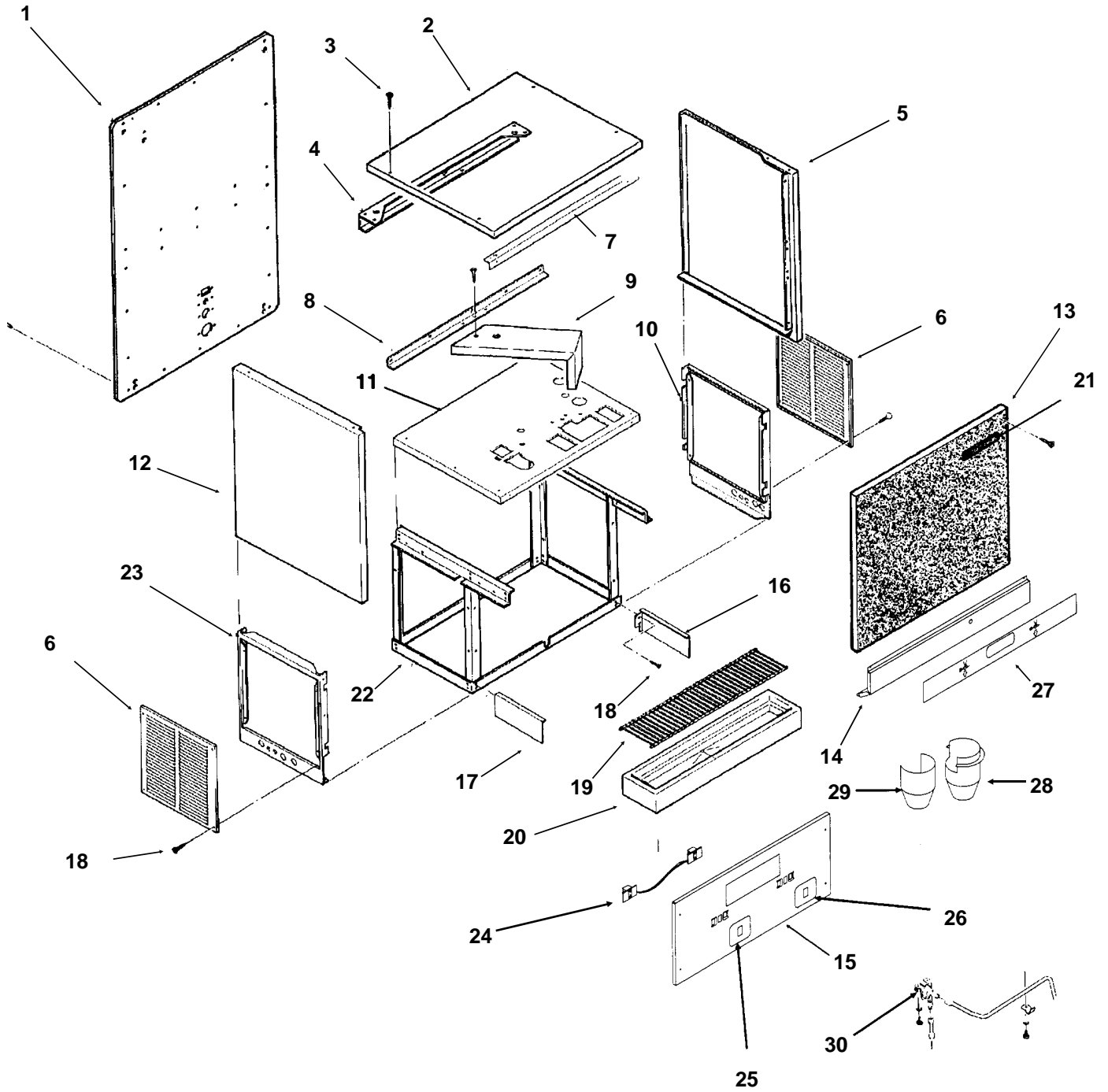

TDE550 & TDE650 SERVICE PARTS

Звонок общенит

vsezip.ru

TDE550

TDE650

ITEM NUMBER	PART NUMBER	DESCRIPTION	ITEM NUMBER	PART NUMBER	DESCRIPTION
1	A32954-001	Back Panel, sandalwood	1	A33112-001	Back Panel, sandalwood
	A32954-015	Back panel, gray		A33112-015	Back panel, gray
	A32954-002	Back Panel, stainless		A33112-002	Back Panel, stainless
2	A32948-001	Top Panel, sandalwood	2	A32948-001	Top Panel, sandalwood
	A32948-015	Top panel, gray		A32948-015	Back panel, gray
	A32948-002	Top Panel, stainless		A32948-002	Top Panel, stainless
3	03-1419-16	Panel screw	3	03-1419-16	Panel screw
4	A32938-001	Hanger Brace	4	A32938-001	Hanger Brace
5	A32947-003	Rt. side panel, sandalwood	5	A33109-003	Rt. side panel, Sandalwood
	A32947-016	Rt. side panel, gray		A33109-016	Right side panel, gray
	A32947-004	Rt. side panel, stainless		A33109-004	Rt. side panel, stainless
6	A33113-001	Service panel, sandalwood	6	A33113-001	Service panel, sandalwood
	A33113-002	Service panel, stainless		A33113-015	Service panel, gray
	A33113-015	Service panel, gray		A33113-002	Service panel, stainless
7	A32939-001	Front Brace	7	A32939-001	Front Brace
8	A32940-001	Support angle	8	A32940-001	Support angle
9	A32949-001	Gearmotor Support	9	A33107-001	Gearmotor Support
10	A32953-001	Rt. side lower, sandalwood	10	A32953-001	Rt. side lower, sandalwood
	A32953-015	Right side lower, gray		A32953-015	Rt. side lower, gray
	A32953-002	Rt. side lower, stainless		A32953-002	Rt. side lower, stainless
11	A32956-001	Upper plate assembly	11	A32956-001	Upper plate assembly
12	A32947-001	Lt. side panel, sandalwood	12	A33109-001	Lt. side panel, sandalwood
	A32947-002	Lt. side panel, ss		A33109-002	Lt. side panel, ss
	A32947-015	Left side panel, gray		A33109-015	Left side panel, gray
13	A32946-001	Up front panel, sandalwood	13	A33108-001	Up front panel, sandalwood
	A32946-002	Upper front panel, gray		A33108-002	Upper front panel, gray
	A34393-001	Up front panel, stainless		A34394-001	Up front panel, stainless
14	A36142-001	Control panel assembly	14	A36142-001	Control panel assembly
15	A36127-020	Splash panel with labels (for enamel-sandalwood)	15	A36127-020	Splash panel with labels (for enamel-sandalwood)
	A36127-021	Splash panel with labels (for stainless steel or gray)		A36127-021	Splash panel with labels (for stainless steel or gray)
16	A34917-001	RH sink support	16	A34917-001	RH sink support
17	A34917-001	LH sink support	17	A34917-001	LH sink support
18	03-1405-17	Screw	18	03-1405-17	Screw
19	02-2951-01	Grill	19	02-2951-01	Grill
20	obsolete	Sink, brown	20	obsolete	Sink, brown
	02-2944-20	Sink, gray		02-2944-20	Sink, gray
21	15-0711-01	Emblem for sandalwood	21	15-0711-01	Emblem for painted
	15-0808-01	Emblem for stainless or gray		15-0808-01	Emblem for stainless or gray
22	A32958-001	Lower frame assy	22	A32958-001	Lower frame assy
23	A32952-001	Lt side lower, sandalwood	23	A32952-001	Lt side lower, sandalwood
	A32952-015	Left side lower, gray		A32952-015	Left side lower, gray
	A32952-002	Lt side lower, stainless		A32952-002	Lt side lower, stainless
24	12-2495-21	Touch free sensors	24	12-2495-21	Touch free sensors
25	17-2288-03	Ice label, tan	25	17-2288-03	Ice label, tan
	17-2288-06	Ice label, grey		17-2288-06	Ice label, grey
26	17-2288-02	Water label, tan	26	17-2288-02	Water label, tan
	17-2288-05	Water label, grey		17-2288-05	Water label, grey
27	17-2288-01	Ice & Water label, tan	27	17-2288-01	Ice & Water label, tan
	17-2288-04	Ice & Water label, grey		17-2288-04	Ice & Water label, grey
28	02-3365-01	Water chute	28	02-3365-01	Water chute
29	02-3270-01	Ice chute	29	02-3270-01	Ice chute
30	12-1646-01	Solenoid Assembly (115v)	30	12-1646-01	Solenoid Assembly (115v)
	12-1646-06	Solenoid (230v)		12-1646-06	Solenoid (230v)
			31	12-2391-01	Key lock, Gov. units only

TDE550 & TDE650 SERVICE PARTS

Air Cooled Refrigeration

vsezip.ru

(812)987-08-81

ITEM NUMBER	PART NUMBER	DESCRIPTION
1	A32961-020	Insulation Kit (3 piece)
2	11-0488-21	Thermo Expansion valve
3	A33330-001	Suction Line for 550
	A33329-001	Suction Line for 650
4	A33194-020	Evaporator
5	03-1420-03	Screw
6	18-8720-21	Compressor, 115v, 60 H
	18-5700-50	verload for 115v comp.
	18-8720-26	Compressor, 230v, 50 H
	18-5700-55	verload for 230v comp.
7	03-1406-10	Hex nut
8	02-3319-02	Washer
9	18-2200-27	Mounting Sleeve
10	18-2200-28	Mounting Grommet
11	18-8736-01	Fan motor, 115v 60 H
	18-8736-06	Fan motor, 230v, 50 H
12	02-3359-01	Fan Bracket
13	11-0485-22	Hi Press. Cut out
14	18-8738-01	Fan Blade
15	A33110-001	Fan Shroud
16	18-8847-01	Condenser
17	03-1645-01	Screw
18	16-0832-20	Access valve
	16-0832-02	Stem cap
	16-0832-20	Access valve

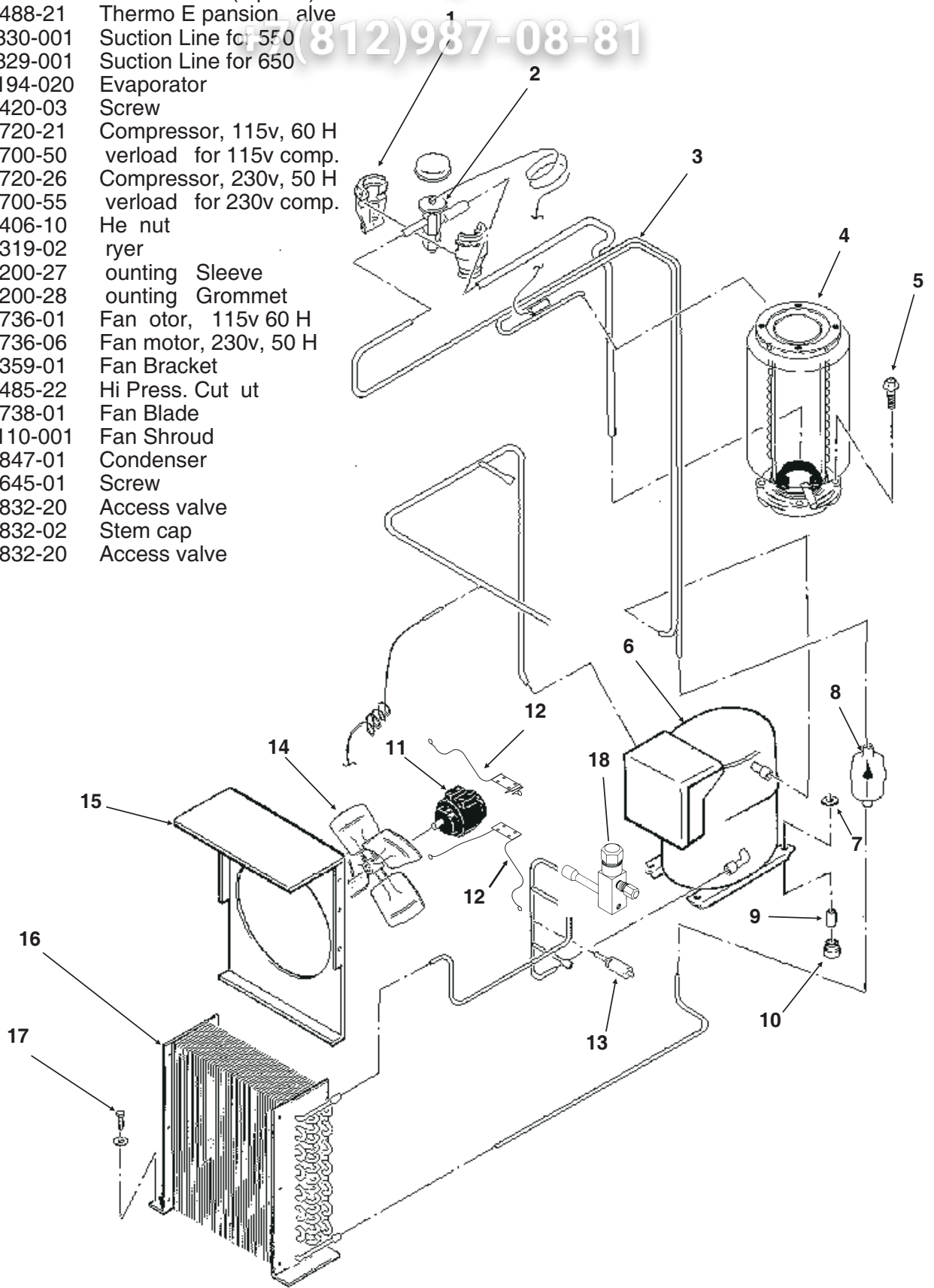

TDE550 & TDE650 SERVICE PARTS

Water Cooled Refrigeration

ITEM NUMBER	PART NUMBER	DESCRIPTION
1	A32961-020	Insulation Kit (3 piece)
2	11-0488-21	Thermo E p. alve
3	A33330-001	Suction Line for 550
	A33329-001	Suction Line for 650
4	A33194-020	Evaporator
5	03-1420-03	Screw
6	02-3319-02	ryer
7	03-1406-10	He ut
8	18-2200-27	ounting Sleeve
9	18-2200-28	ounting Grommet
10	18-8720-21	Compressor, 115v 60 H
	18-5700-50	verload for 115v comp.
	18-8720-26	Compressor, 230v, 50 H
	18-5700-55	verload for 230v comp.
11	16-0832-20	Access valve
12	11-0485-22	High Press. Cut ut
13	11-0478-01	Water Reg. alve
14	A31828-002	Adaptor Flange
15	A31828-001	Adaptor Flange
16	03-1405-17	Screw
17	03-1410-03	Lock washer
18	18-3305-25	Condenser

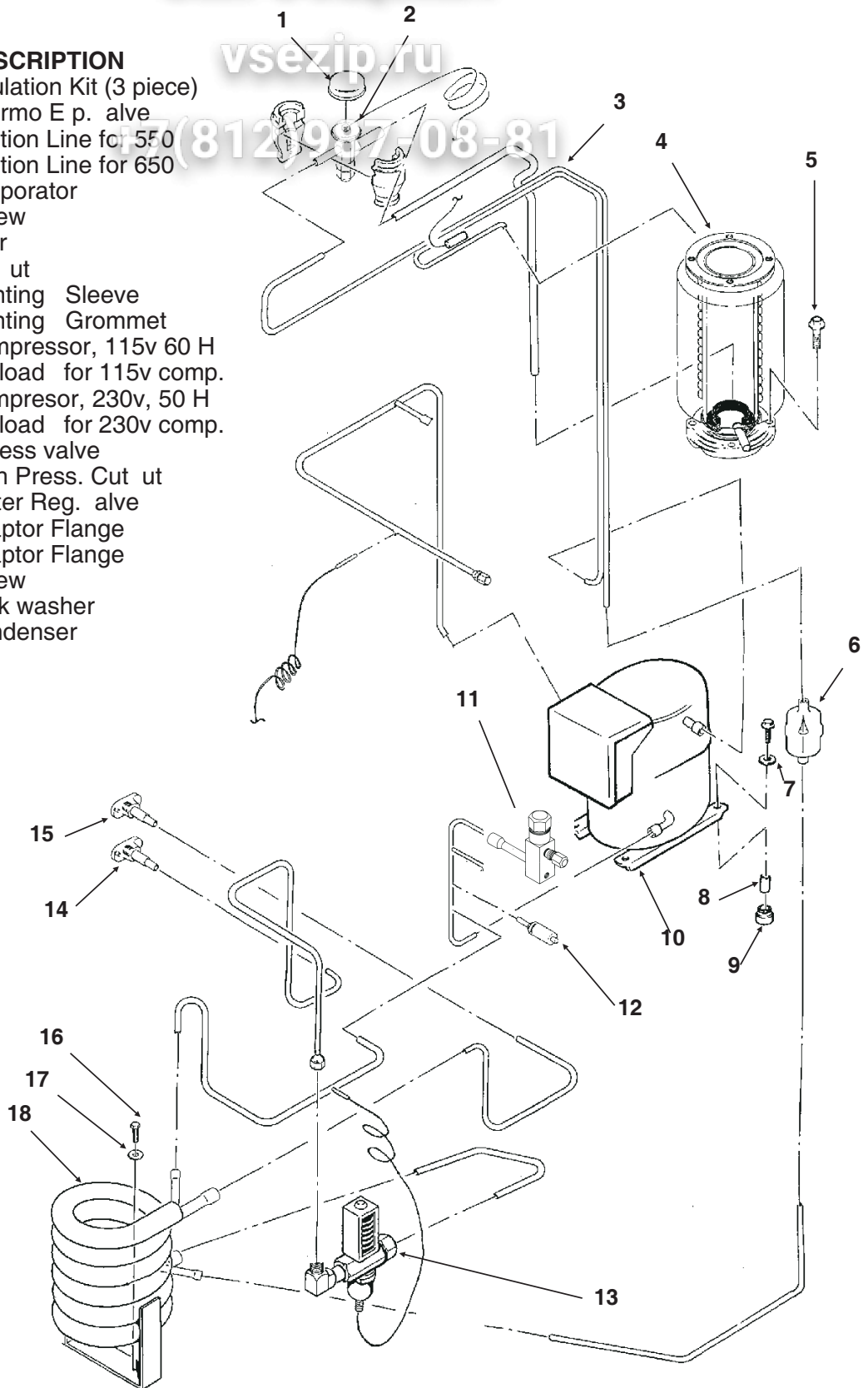

TDE550 & TDE650 SERVICE PARTS

Ice Dispensing

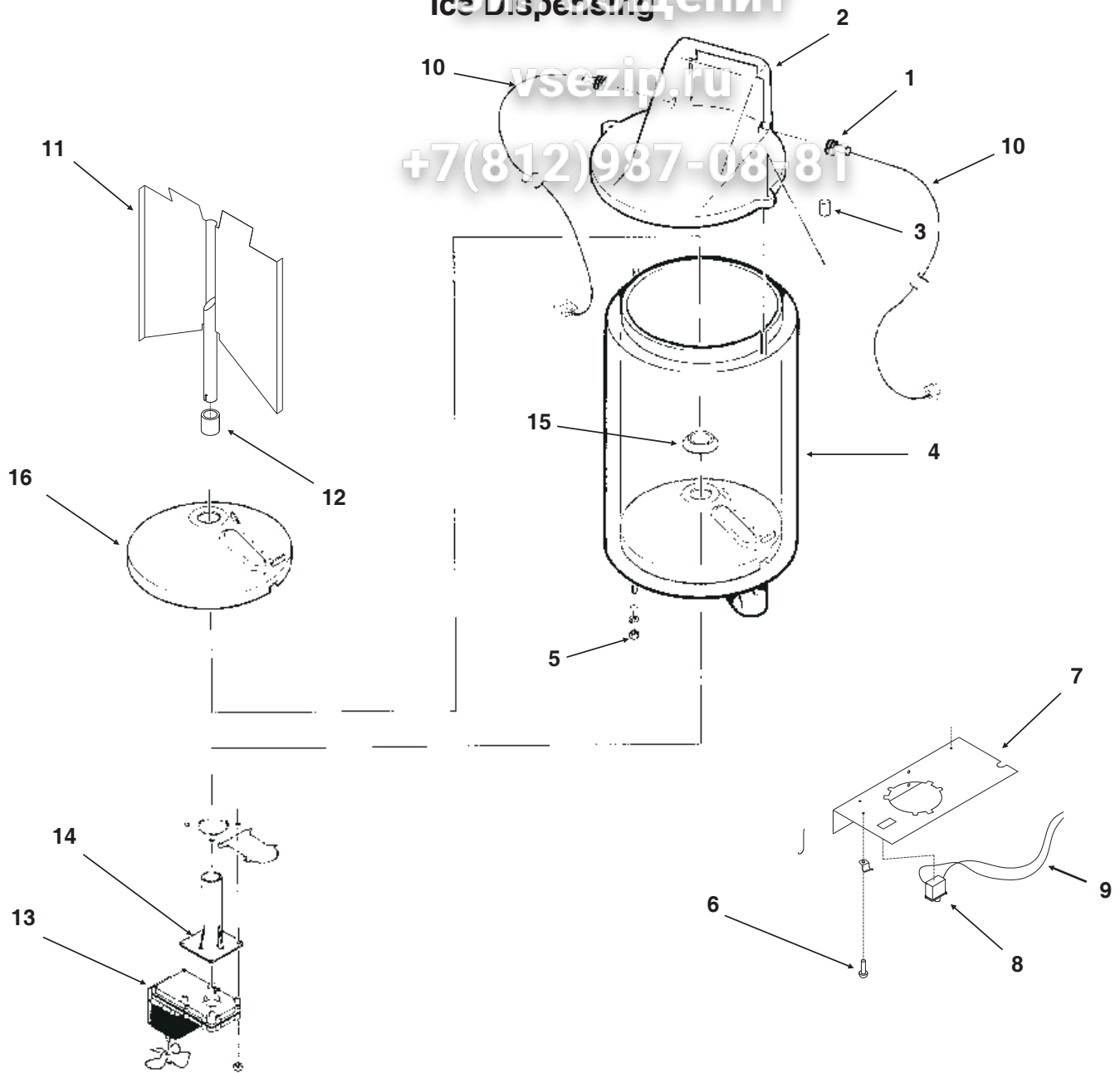

ITEM NUMBER	PART NUMBER	DESCRIPTION
1	13-0866-01	Grommet, Bin Control
2	A34493-003	Bin top
3	03-0255-00	Wing nut
4	A34496-001	T E550 Storage Bin
	A34496-002	T E650 Storage Bin
5	03-1406-09	Hex nut
	03-1410-03	Lock washer
6	03-1531-01	Screw
7	A36053-001	Alve plate
8	12-2501-01	Switch (Touch Free off)
9	no number	Wires
10	A37710-021	Ice Level Sensor (set)

ITEM NUMBER	PART NUMBER	DESCRIPTION
11	A37268-001	T E550 Bin vane (inc. 12)
	A37267-001	T E650 Bin vane (inc. 12)
12	02-3327-01	Bearing
13	12-2677-21	Bin rivet (115v)
	12-2677-26	Bin rivet (230v)
14	02-1971-00	Bracket
15	13-0747-00	Water Shed
16	A32657-001	Bin Bottom

TDE550 & TDE650 SERVICE PARTS

Вир. ОбщениТ

vsezip.ru

+7(812)987-08-81

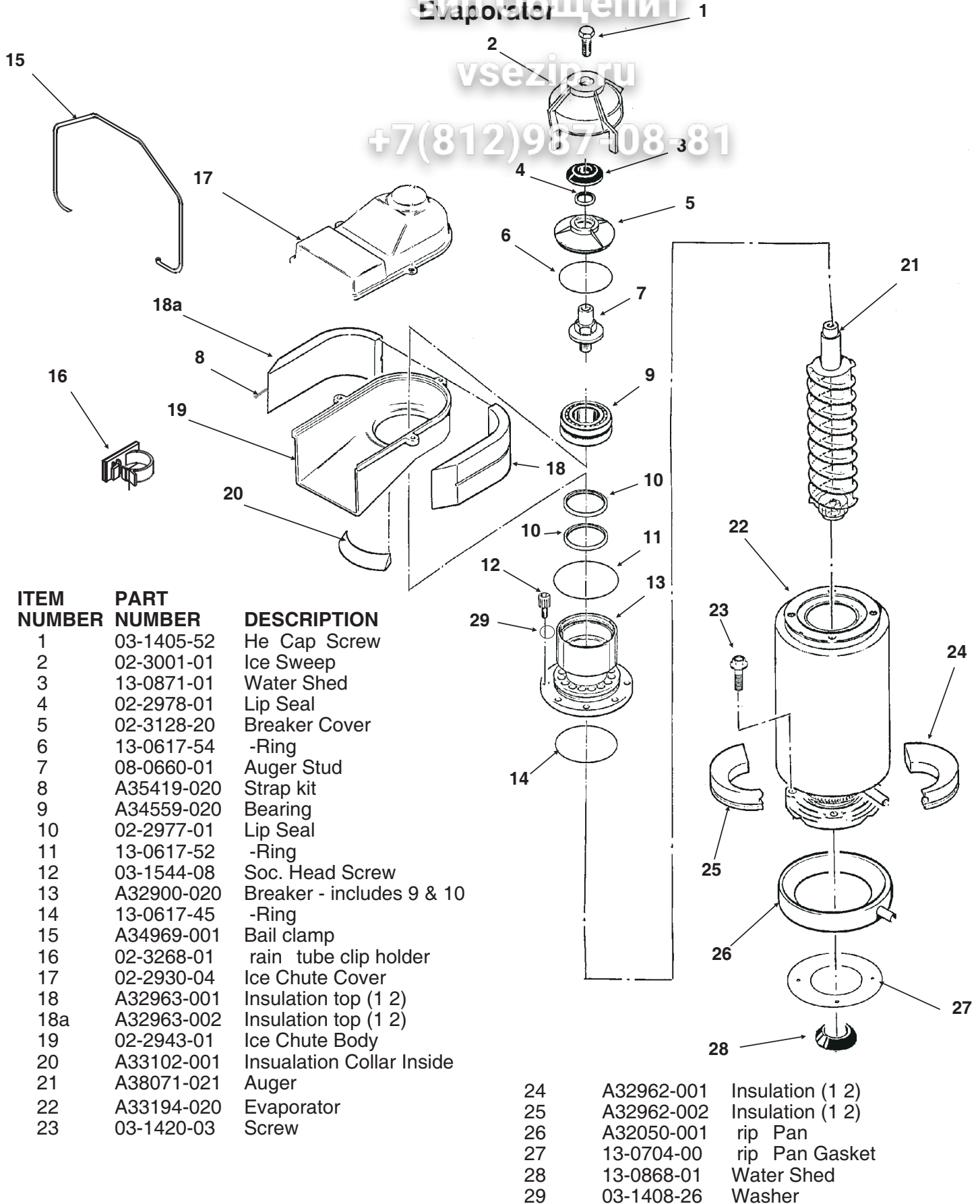

ITEM NUMBER	PART NUMBER	DESCRIPTION
1	03-1405-52	He Cap Screw
2	02-3001-01	Ice Sweep
3	13-0871-01	Water Shed
4	02-2978-01	Lip Seal
5	02-3128-20	Breaker Cover
6	13-0617-54	-Ring
7	08-0660-01	Auger Stud
8	A35419-020	Strap kit
9	A34559-020	Bearing
10	02-2977-01	Lip Seal
11	13-0617-52	-Ring
12	03-1544-08	Soc. Head Screw
13	A32900-020	Breaker - includes 9 & 10
14	13-0617-45	-Ring
15	A34969-001	Bail clamp
16	02-3268-01	rain tube clip holder
17	02-2930-04	Ice Chute Cover
18	A32963-001	Insulation top (1 2)
18a	A32963-002	Insulation top (1 2)
19	02-2943-01	Ice Chute Body
20	A33102-001	Insulation Collar Inside
21	A38071-021	Auger
22	A33194-020	Evaporator
23	03-1420-03	Screw

24	A32962-001	Insulation (1 2)
25	A32962-002	Insulation (1 2)
26	A32050-001	rip Pan
27	13-0704-00	rip Pan Gasket
28	13-0868-01	Water Shed
29	03-1408-26	Washer

TDE550 & TDE650 SERVICE PARTS

Gearmotor Assembly

vse.ru

+7(812)987-08-81

***NOTE: GEARCASE COVER INCLUDES COVER, OUTPUT SHAFT, KEY, OUTPUT GEAR, BEARINGS AND SEAL**

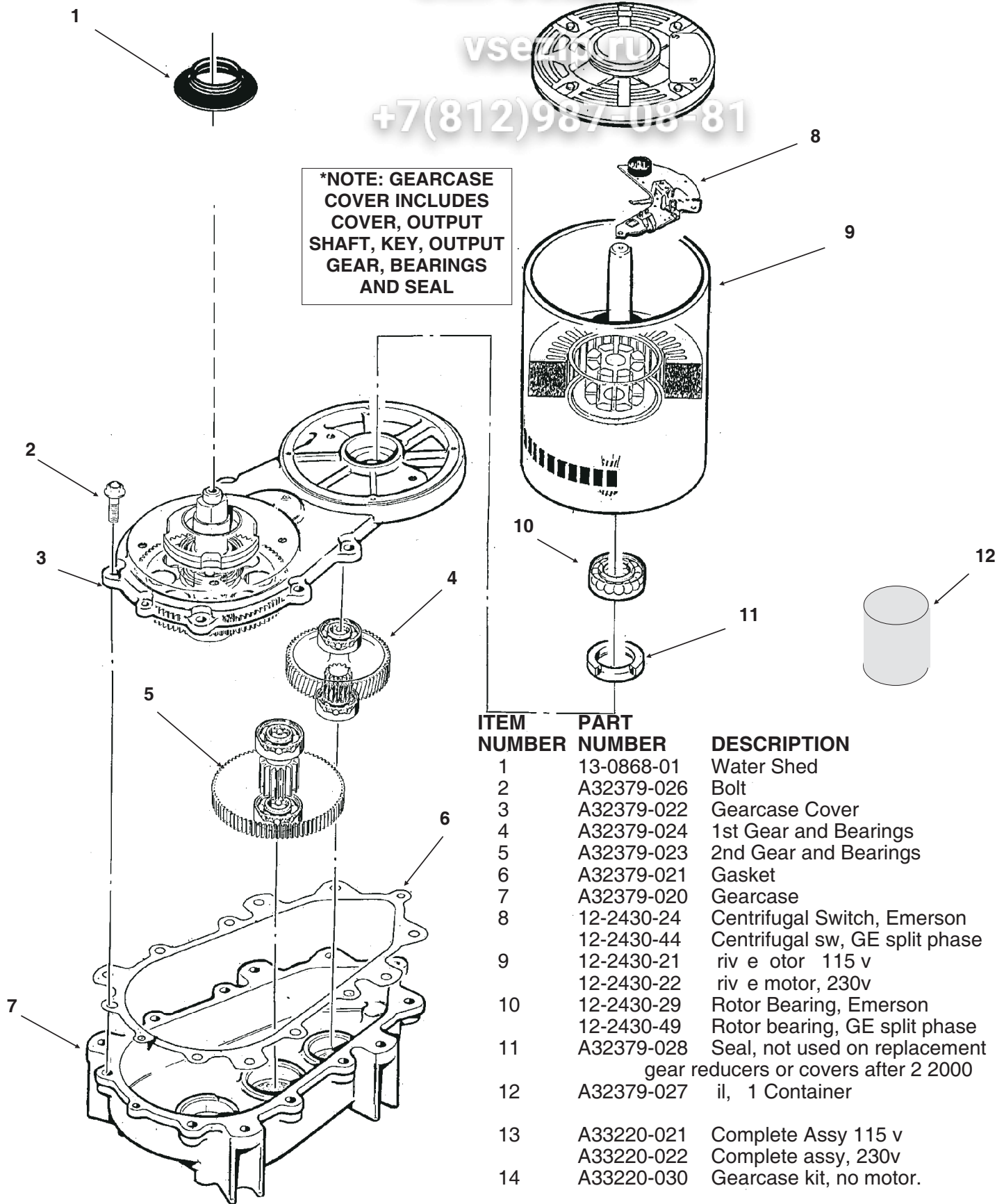

ITEM NUMBER	PART NUMBER	DESCRIPTION
1	13-0868-01	Water Shed
2	A32379-026	Bolt
3	A32379-022	Gearcase Cover
4	A32379-024	1st Gear and Bearings
5	A32379-023	2nd Gear and Bearings
6	A32379-021	Gasket
7	A32379-020	Gearcase
8	12-2430-24	Centrifugal Switch, Emerson
9	12-2430-44	Centrifugal sw, GE split phase
10	12-2430-21	rive otor 115 v
11	12-2430-22	rive motor, 230v
12	12-2430-29	Rotor Bearing, Emerson
13	12-2430-49	Rotor bearing, GE split phase
14	A32379-028	Seal, not used on replacement gear reducers or covers after 2 2000
15	A32379-027	il, 1 Container
16	A33220-021	Complete Assy 115 v
17	A33220-022	Complete assy, 230v
18	A33220-030	Gearcase kit, no motor.

TDE550 & TDE650 SERVICE PARTS

всё что нужно для ремонта

vsezip.ru

+7(812)987-08-81

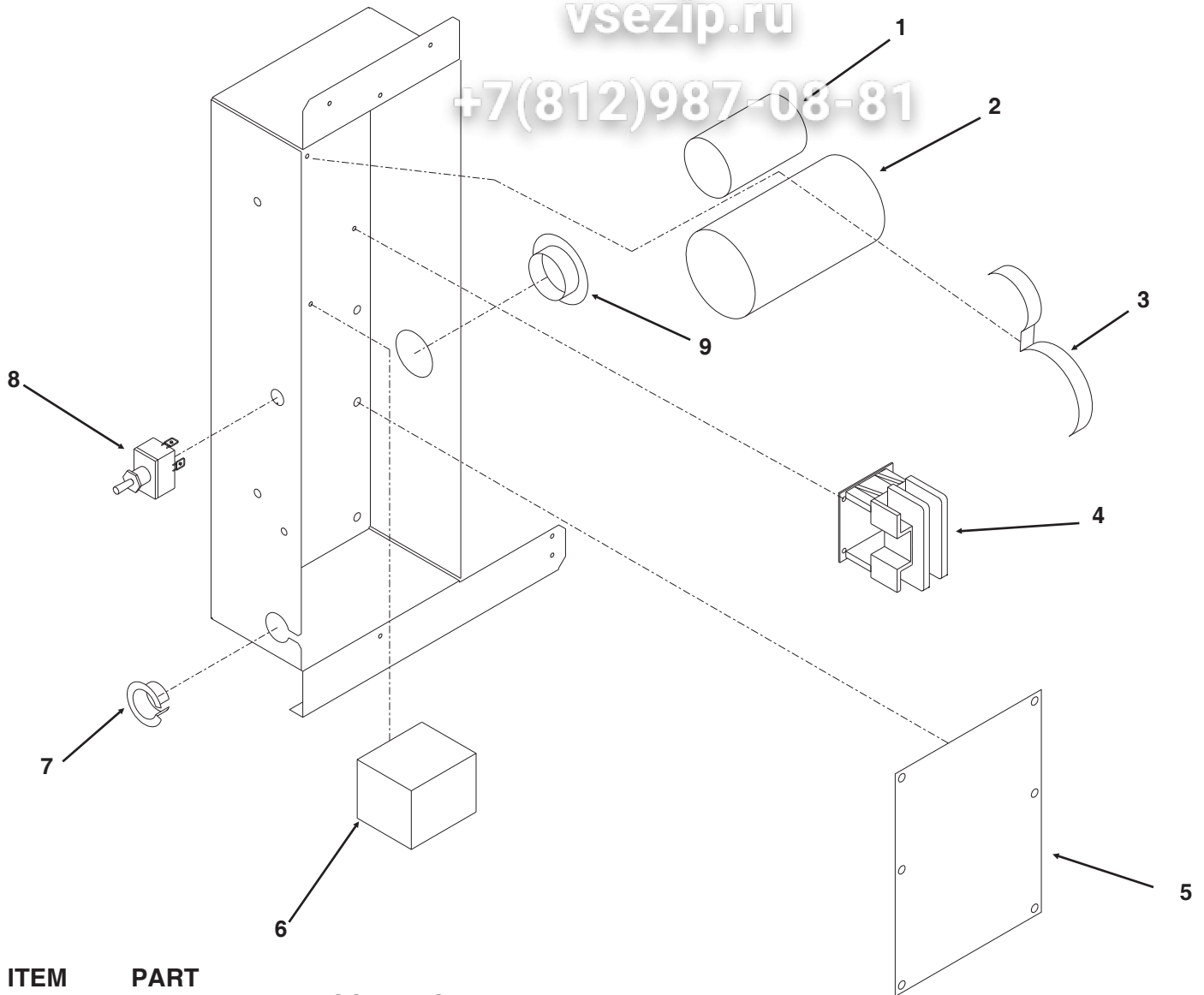

ITEM NUMBER	PART NUMBER	DESCRIPTION
1	18-1902-52	Run capacitor, 115v, 60 H
2	18-1901-49	Start Capacitor, 115v 60 H
	18-2200-35	Start capacitor, 230v. 50 H
	18-2200-38	Cap for start capacitor
3	A36141-001	Capacitor strap
4	12-2469-03	Contactora, 115v, 60 H
	12-2469-02	Contactora, 230v, 50 H
5	12-2843-21	60 H (115v) circuit board
	12-2487-22	50 H (230v) circuit board
5a	12-2499-01	Standoff for circuit board
6	18-1903-44	Potential Relay, 115v, 60 H
	18-1903-48	Potential Relay, 230v, 50 H
7	12-1213-10	Bushing
8	12-0426-01	Switch
9	12-1213-12	Bushing
10	A36146-001	Control box cover (not shown)

TDE550 & TDE650 SERVICE PARTS

Water System

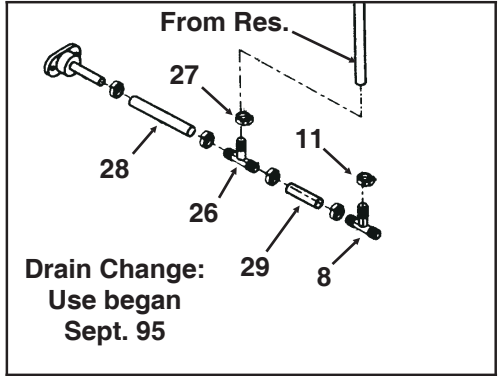
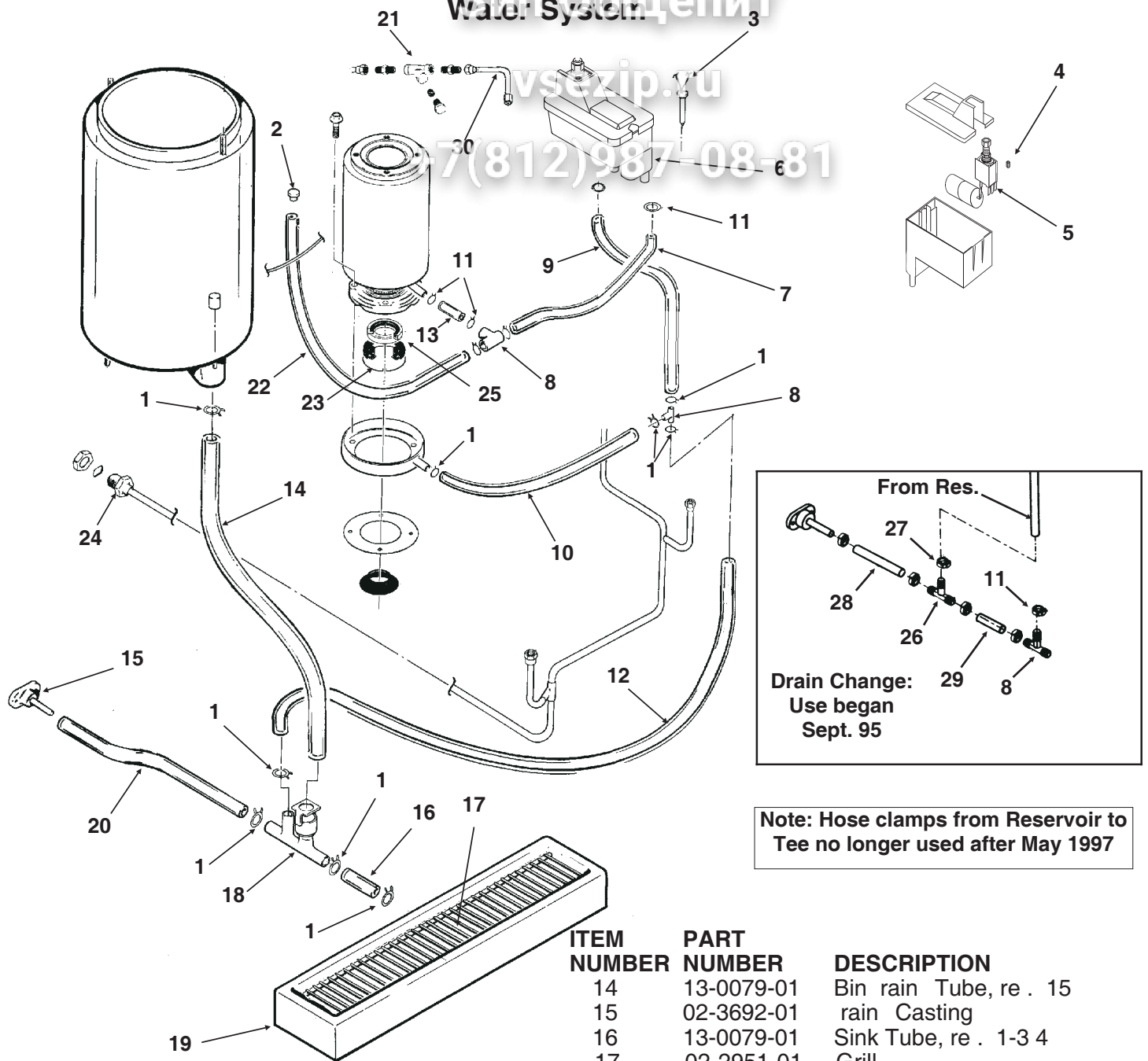

Note: Hose clamps from Reservoir to Tee no longer used after May 1997

ITEM NUMBER	PART NUMBER	DESCRIPTION	ITEM NUMBER	PART NUMBER	DESCRIPTION
1	02-2814-09	Clamp	14	13-0079-01	Bin rain Tube, re . 15
2	13-0840-01	Plug	15	02-3692-01	rain Casting
3	A33101-022	Water Level Sensor	16	13-0079-01	Sink Tube, re . 1-3 4
4	02-3266-03	Plunger seat	17	02-2951-01	Grill
5	02-3266-21	Float valve	18	A36962-001	rain kit
6	02-3266-20	Reservoir Assy, complete	19	02-2944-20	Sink
7	13-0674-06	Tubing, re uires 6	20	13-0079-01	rain Tube, re . 8
8	16-0670-01	Tee	21	16-0162-00	Strainer - not used after 11 97
9	13-0674-09	Tubing, re uires 4.5	22	13-0674-09	rain Tube, re . 23
10	13-0674-09	Tubing, re uires 4.5	23	A32777-001	Retaining Ring
11	02-2814-08	Clamp	24	A27318-001	Inlet Fitting (only) for copper
12	13-0079-03	rain Tube, T E550 re . 39 T E650 re . 46		16-0835-01	Inlet fitting for plastic ale connector
13	13-0674-06	Evap. Inlet Tube, re 5	25	02-0929-23	Water Seal
			26	16-0670-04	Tee
			27	02-2814-07	Clamp
			28	13-0679-01	rain tube 6.5 re .
			29	13-0679-01	rain tube, 2.5 re .
			30	13-0895-01	Plastic tubing, order by foot

TDE550 & TDE650 SERVICE PARTS

115/60/1 Wiring Diagram up to serial number: 879516-05M

vsezip.ru

+7(812)987-08-81

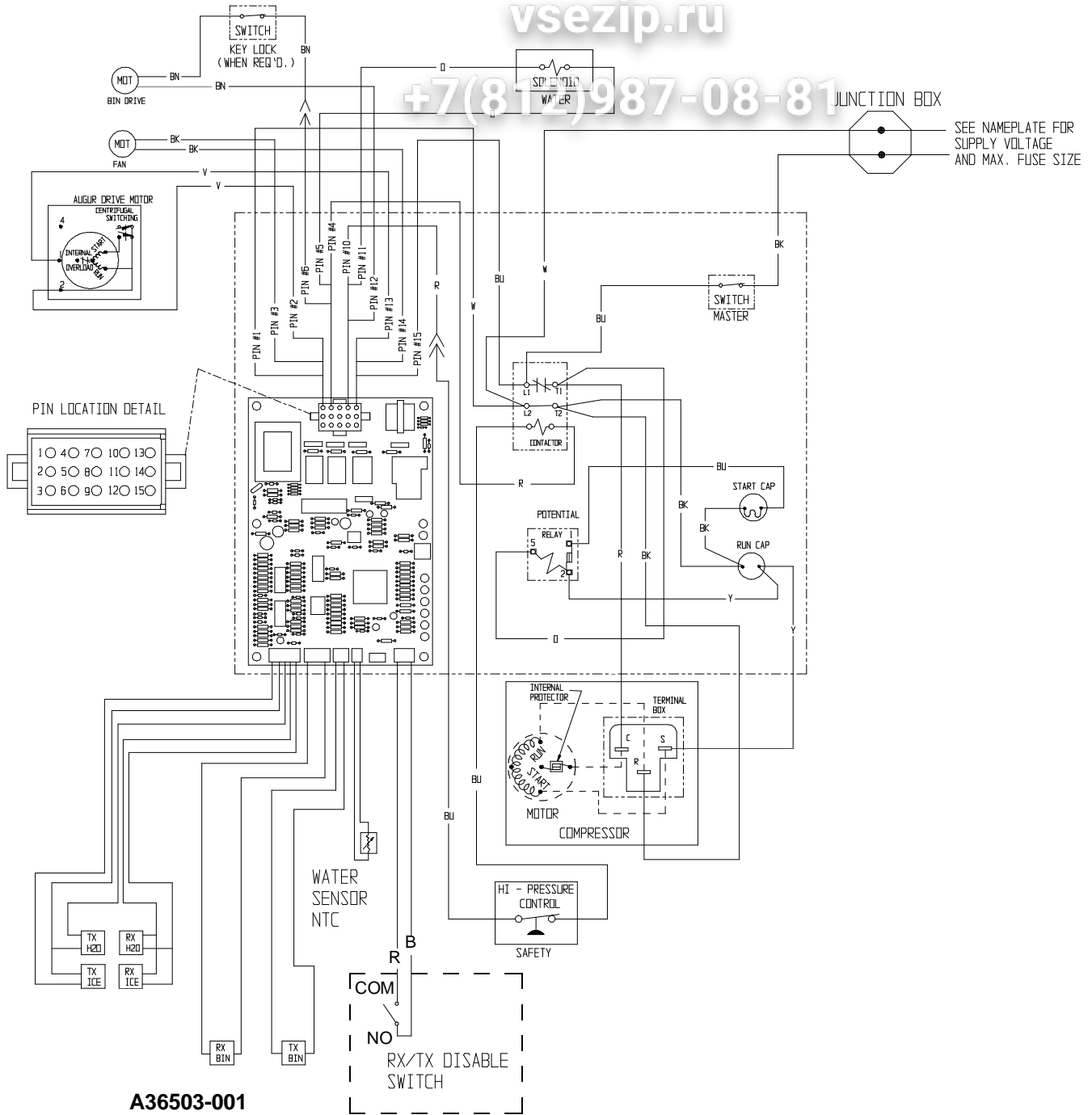

TDE550 & TDE650 SERVICE PARTS

115/60/1 Schematic Diagram up to serial number: 879516-05M

vsezip.ru

+7(812)987-08-81

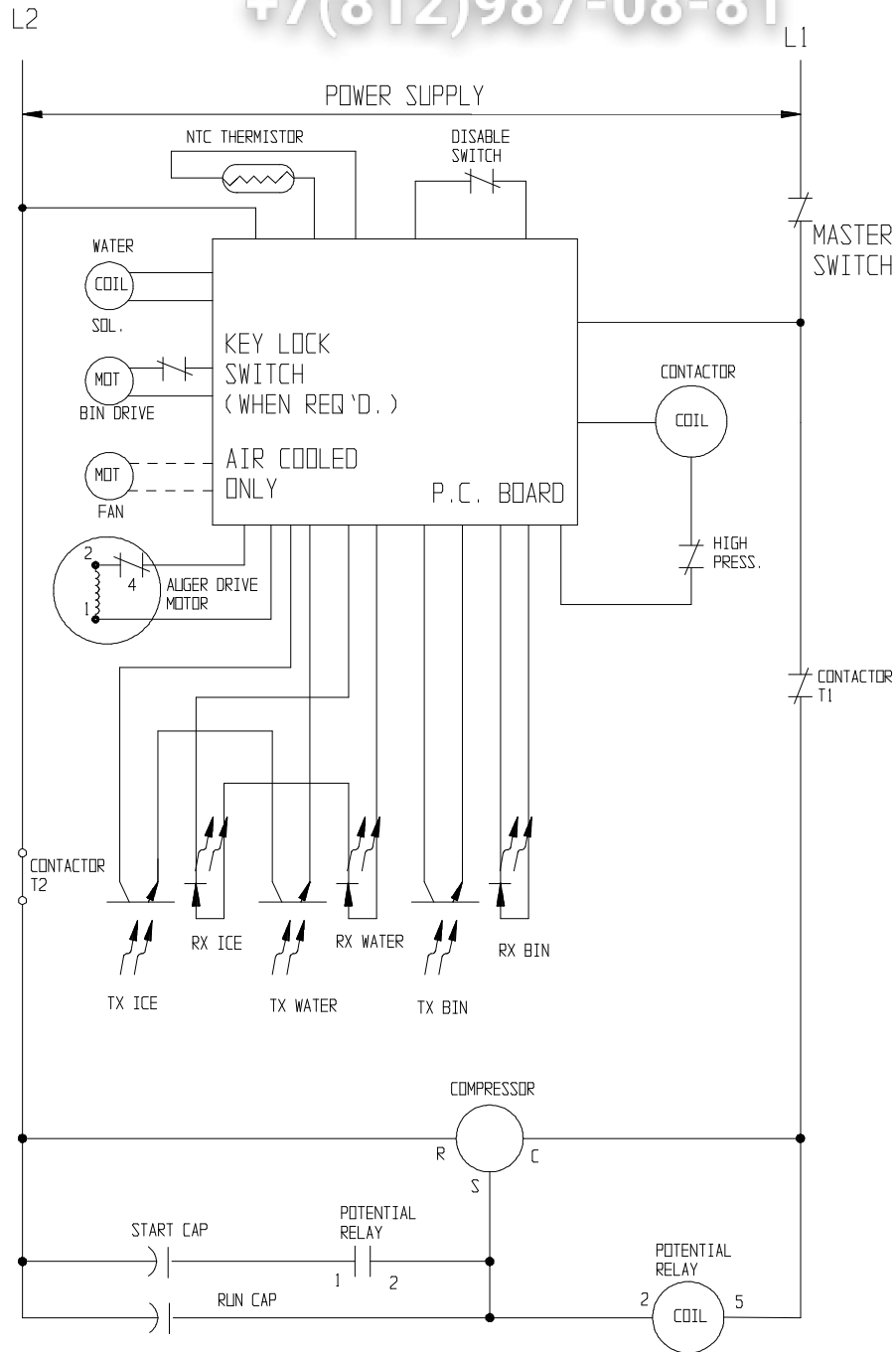

USE COPPER CONDUCTORS ONLY.
THIS UNIT MUST BE GROUNDED.
ALL CONTROLS SHOWN IN NORMAL ICE
MAKING MODE WITH ALL DISPENSING
SYSTEMS IN OPERATION.

TDE550 & TDE650 SERVICE PARTS

230/50/1 Wiring Diagram up to serial number: 879516-05M

vsezip.ru

+7(812)987-08-81

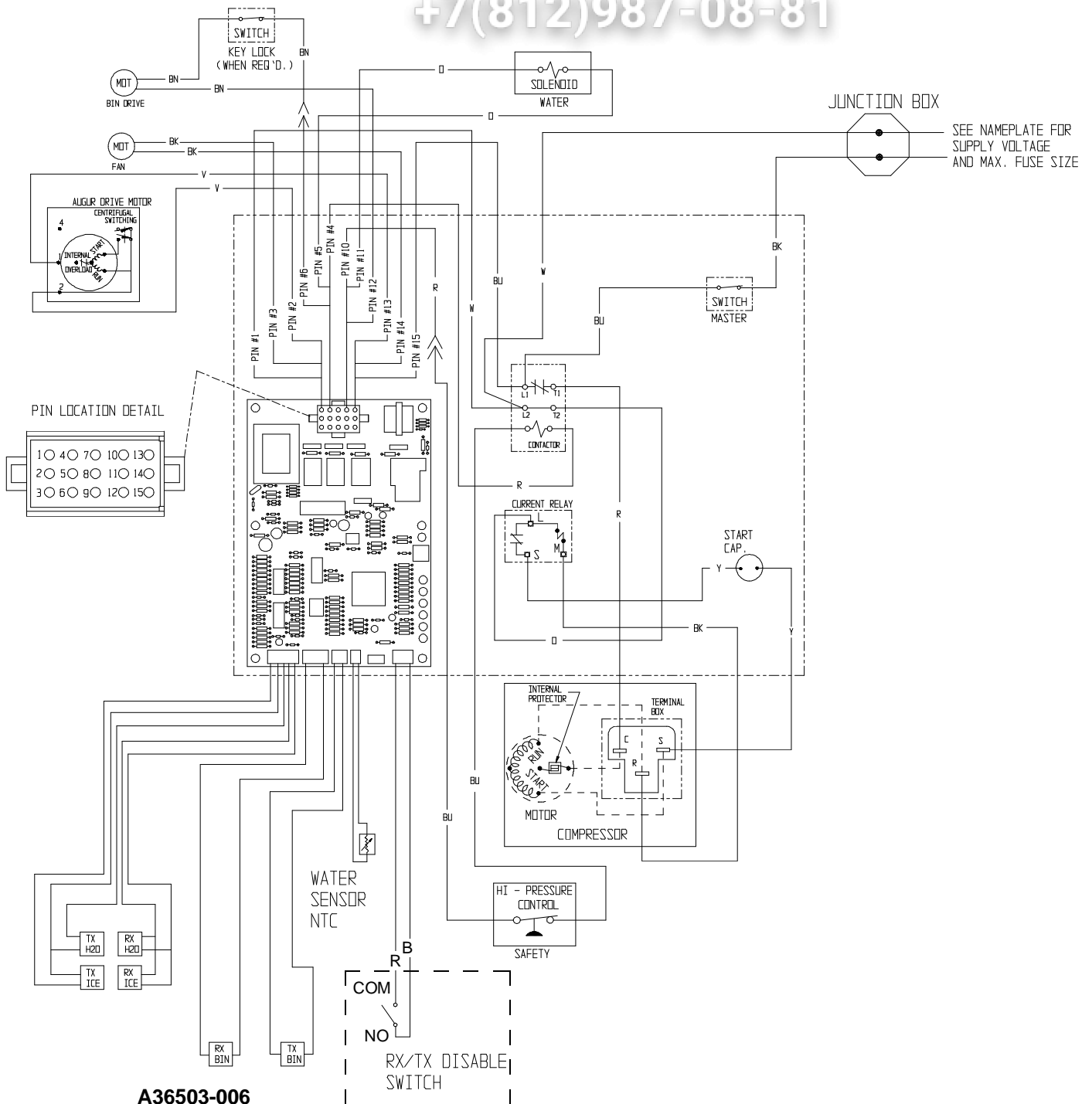

TDE550 & TDE650 SERVICE PARTS

230/50/1 Schematic Diagram up to serial number: 879516-05M

vsezip.ru

+7(812)987-08-81

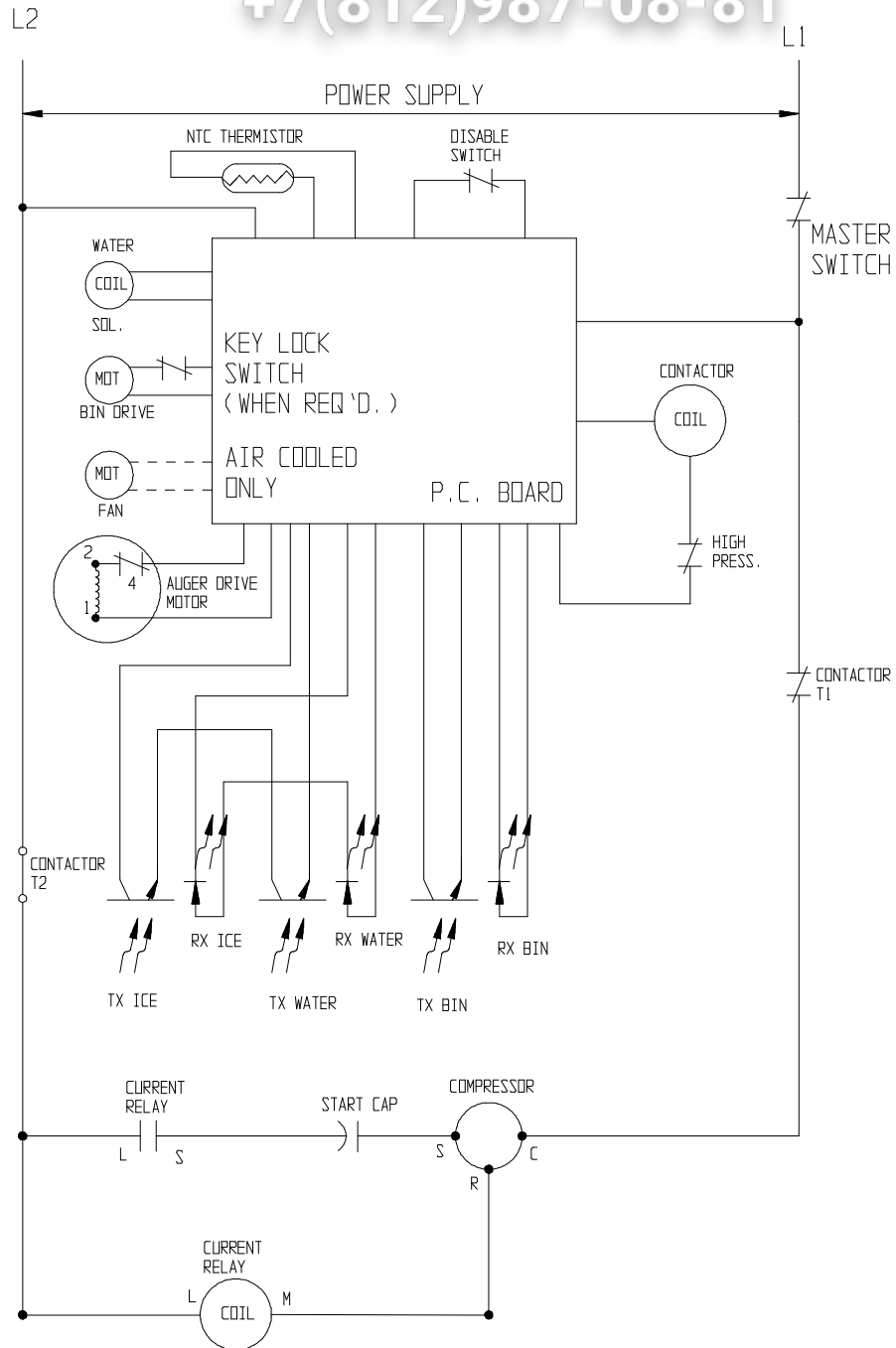

USE COPPER CONDUCTORS ONLY.
THIS UNIT MUST BE GROUNDED.
ALL CONTROLS SHOWN IN NORMAL ICE
MAKING MODE WITH ALL DISPENSING
SYSTEMS IN OPERATION.

TDE550 & TDE650 SERVICE PARTS

115/60/1 Wiring Diagram after Serial number: 879516-05M

vsezip.ru

+7(812)987-08-81

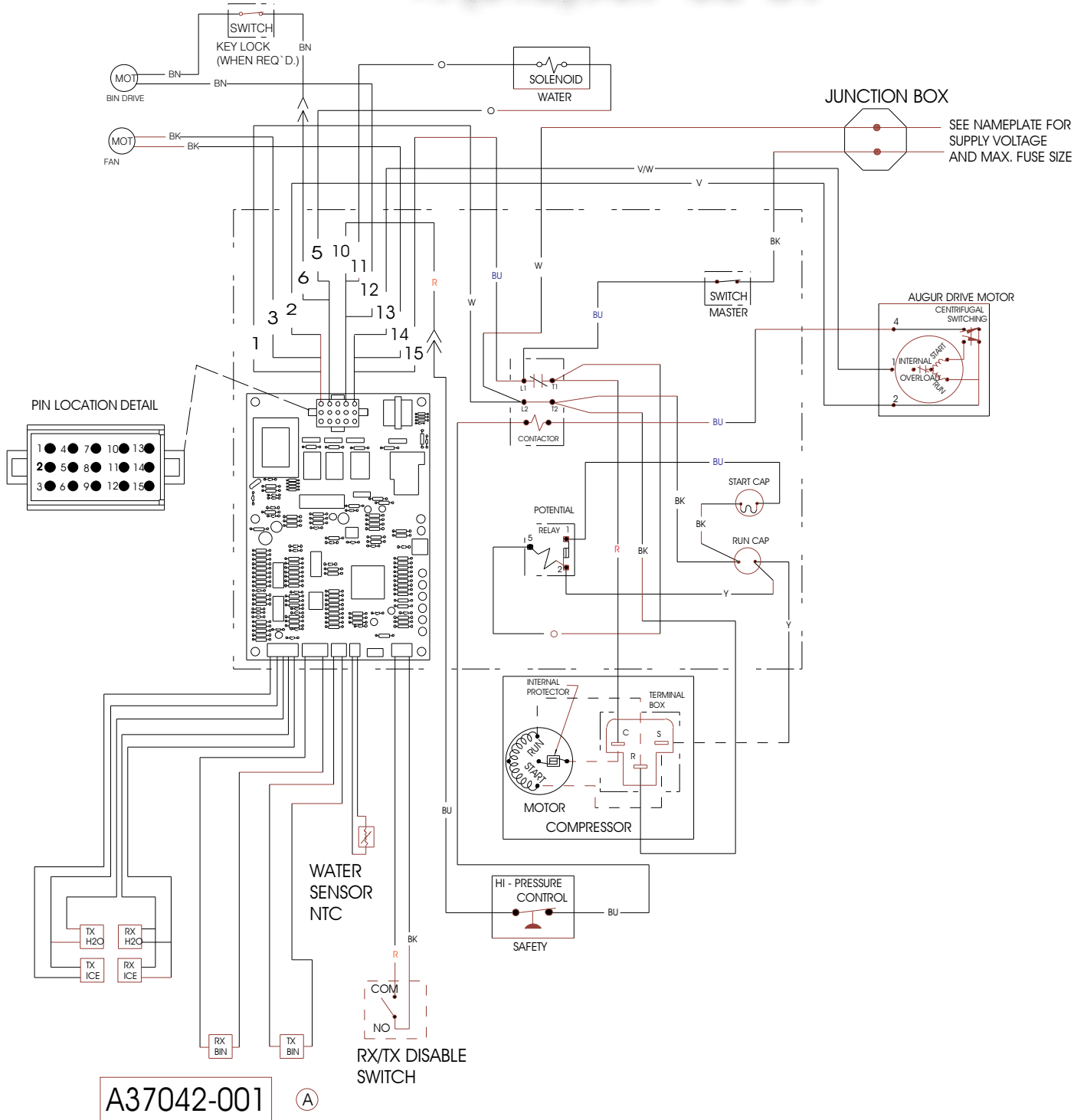

TDE550 & TDE650 SERVICE PARTS

115/60/1 Schematic Diagram after serial number: 879516-05M

vsezip.ru

+7(812)987-08-81

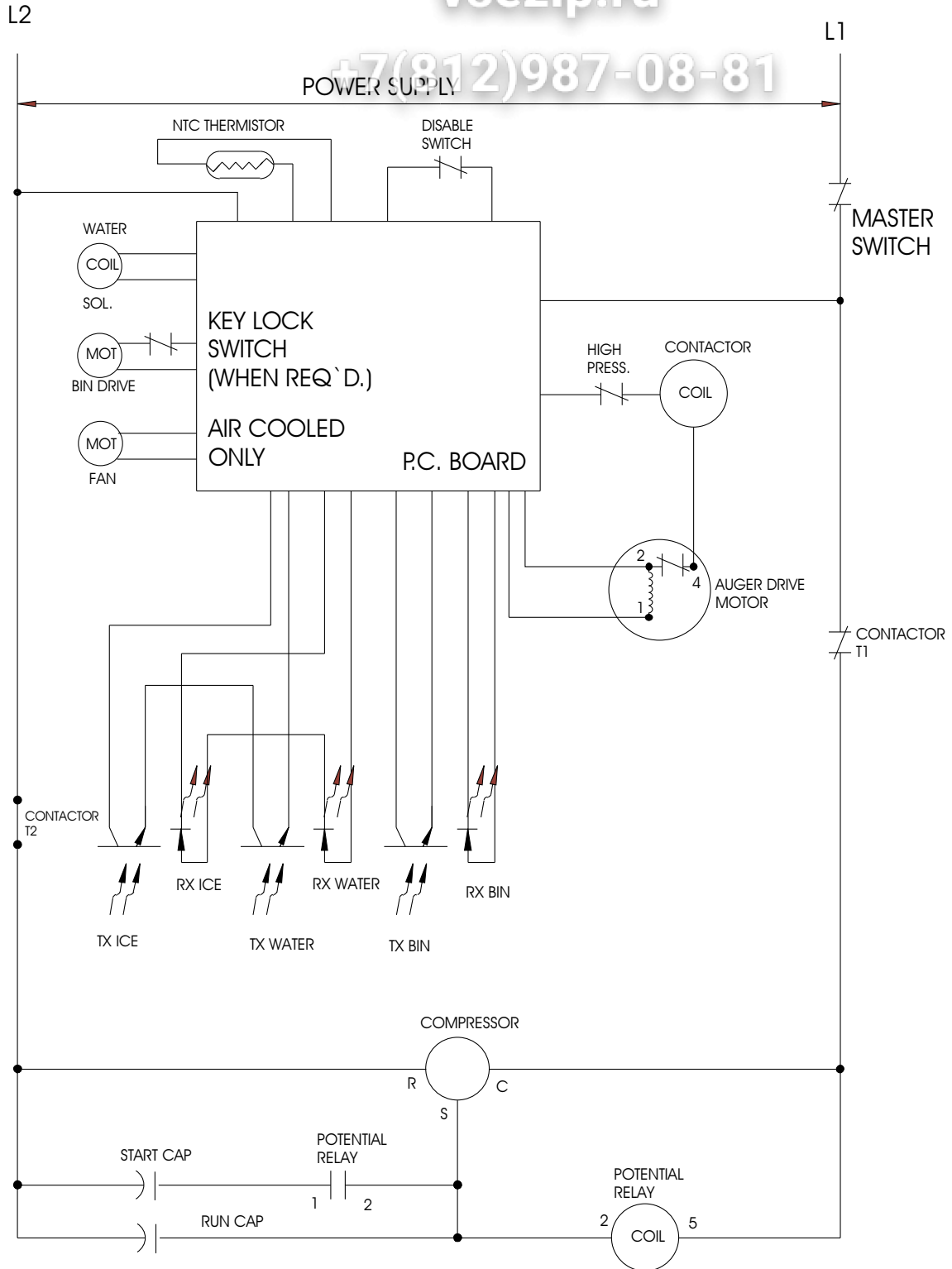

USE COPPER CONDUCTORS ONLY.
 THIS UNIT MUST BE GROUNDED.
 ALL CONTROLS SHOWN IN NORMAL ICE
 MAKING MODE WITH ALL DISPENSING
 SYSTEMS IN OPERATION.

TDE550 & TDE650 SERVICE PARTS

230/50/1 Wiring Diagram after serial number: 879516-05M

vsezip.ru

+7(812)987-08-81

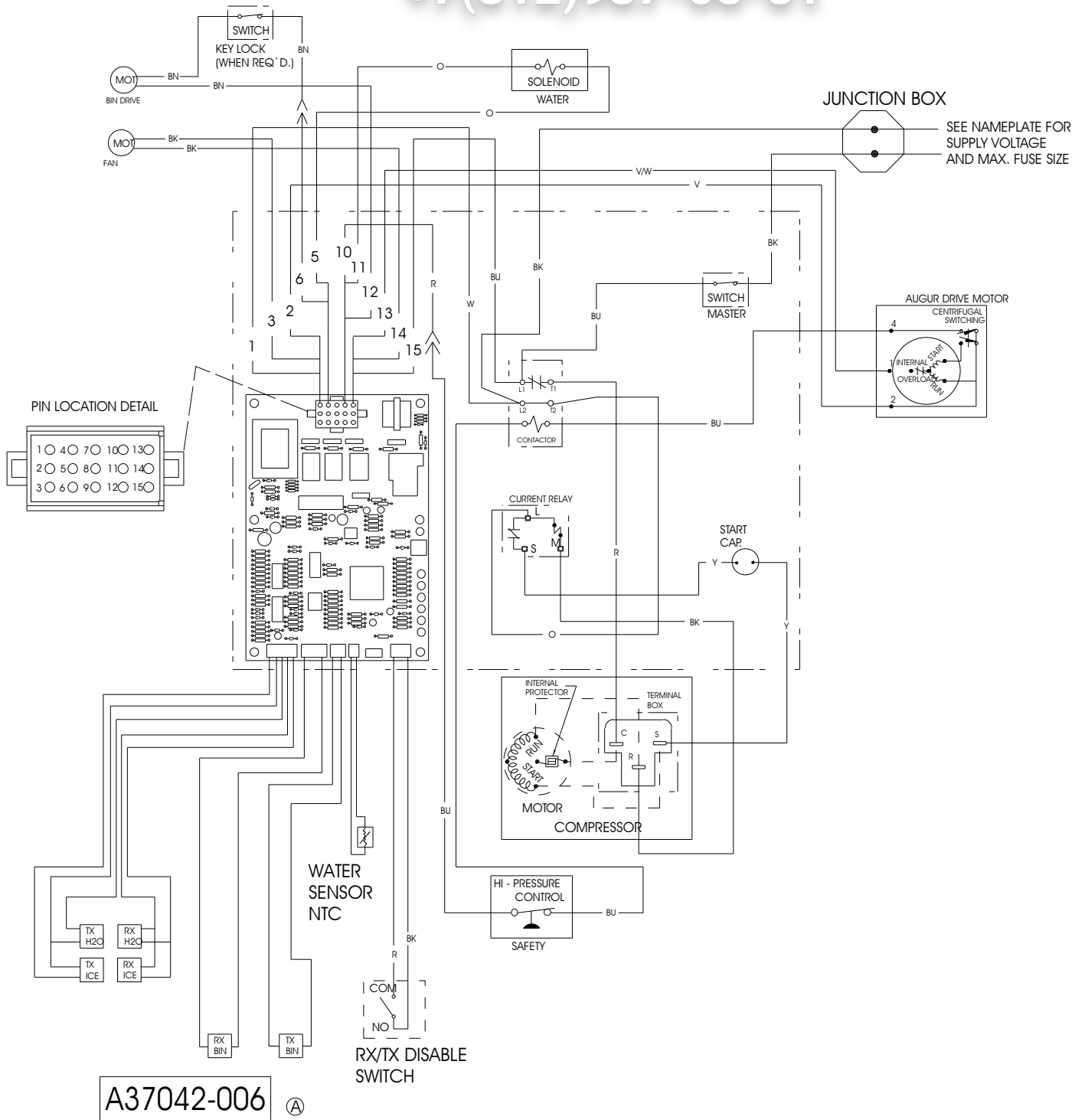

TDE550 & TDE650 SERVICE PARTS

230/50/1 Schematic Diagram after serial number: 879516-05M

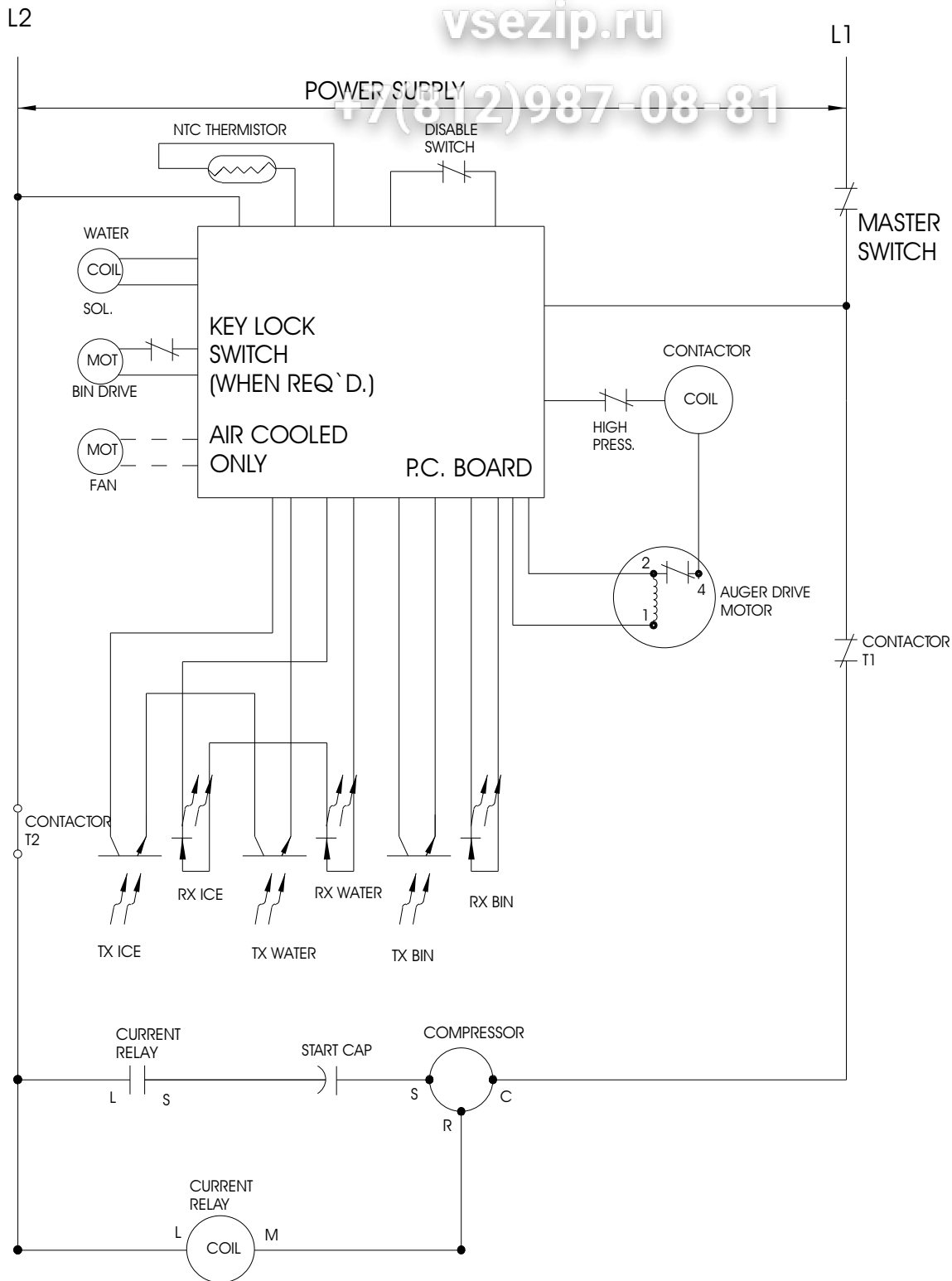

USE COPPER CONDUCTORS ONLY.
 THIS UNIT MUST BE GROUNDED.
 ALL CONTROLS SHOWN IN NORMAL ICE
 MAKING MODE WITH ALL DISPENSING
 SYSTEMS IN OPERATION.

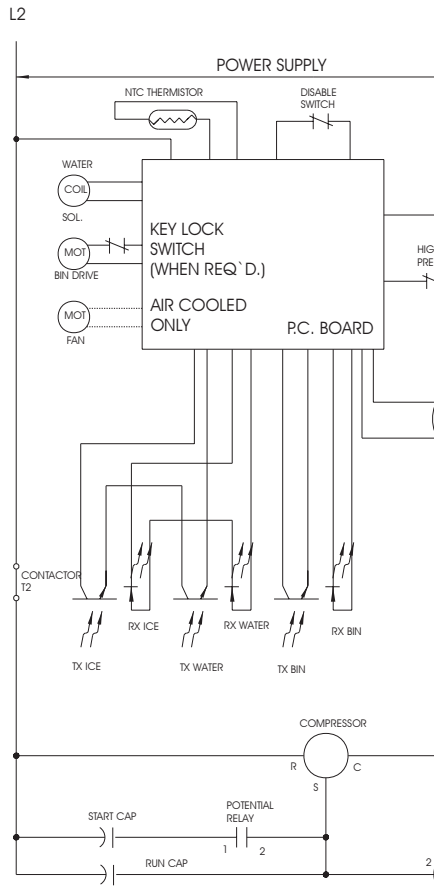
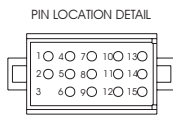
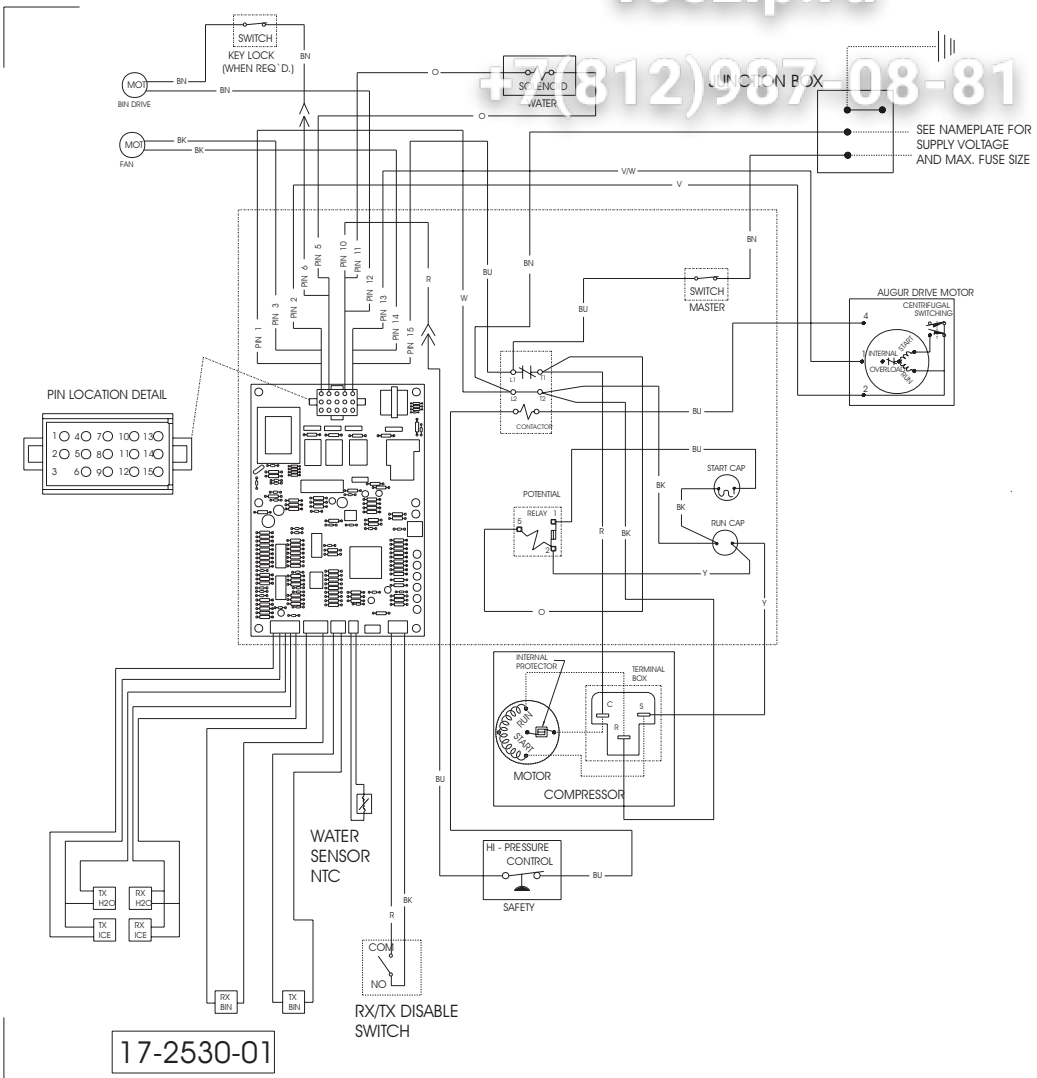

USE COPPER CONDUCTORS ONLY.
 THIS UNIT MUST BE GROUNDED.
 ALL CONTROLS SHOWN IN NORMAL ICE
 MAKING MODE WITH ALL DISPENSING
 SYSTEMS IN OPERATION.

17-2530-01