

Зип Общепит

vsezip.ru

+7(812)987-08-81

RACK CONVEYOR MACHINE

ELECTRONICAL SWITCHES
LOWER AND UPPER WASHER

TYPE: 91

Accessories

HEAT RECOVERY - TR71

STEAM CONDENSER - LC 71

DRYER - LC 70

DRYER MECHANICS CURVE LC 77/4

SPLASH ZONE - LC 73

TANK INSULATION

DOUBLE SKIN

BOOSTER PUMP

DISPENSER SYSTEM SDN-3

SANITIZATION SYSTEM

ANGLE LOADING TABLE - LC 98

Spare parts Manual

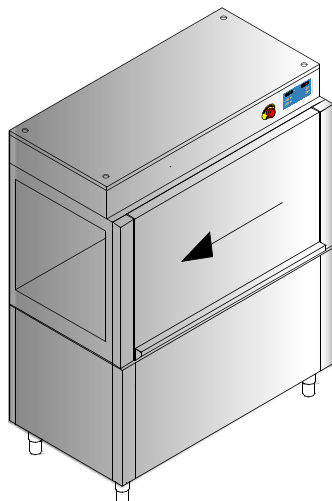

INFORMAZIONI GENERALI

Questo catalogo serve per richiedere con esattezza le parti di ricambio

Nelle ordinazioni indicare:

1) il numero dei codici dei particolari seguito dalla descrizione e la quantità desiderata;

2) Il codice alfa-numerico presente nella seconda colonna della tabella ;

I disegni delle parti di ricambio sono solo indicativi e non rappresentano il pezzo in oggetto.

I dati contenuti in questo catalogo sono indicativi e possono essere soggetti a modifiche senza impegno di preavviso.

ALLGEMEINE INFORMATIONEN

Dieser Ersatzteilkatalog dient zur genauen Angabe der Teile bei Ersatzteilbestellungen.

Bei Ersatzbestellung ist folgendes anzugeben:

1) Die Bestellnummer der Ersatzteile mit der entsprechenden Beschreibung genaue Menge;

2) Der alpha-numerischer Code auf der zweiten Reihe in dein Sculd;

Die Zeichnungen der Ersatzteile sind nur als Hinweise gedacht und stellen nicht das betroffene Teil dar.

Bei den im Katalog angeführten Daten handelt es sich um Anhaltsdaten, die jederzeit, ohne Vorankündigung, geändert werden können.

GENERAL INFORMATION

The present spare parts order exactly the right spare parts

When ordering specify:

1) the part's code number followed by its description and quantity needed;

2) The alpha-numeric code is in the second column in the chart;

Spare parts drawings are general and do not represent the part.

The contents of this catalogue are general and can undergo changes without prior notice.

INFORMACIONES GENERALES

El presente catálogo sirve para pedir con exactitud las partes de repuesto

En los pedidos se debe indicar:

1) el número de código de la parte y a continuación la descripción cantidad deseada;

2) El código alfanumerico presente en la segnada columna de la tabla;

Los diseños de las partes de recambio son solo indicativos y no representan la pieza en cuestión.

Los datos contenidos en el presente catálogo son indicativos y pueden modificarse sin aviso previo.

INFORMATIONS GENERALES

Ce catalogue permet de commander correctement les pièces détachées

Les commandes doivent être passées en indiquant:

1) le numero de code des pièces détachées suivi de leur description quantité désirée;

2) le code alphanumérique dans la deuxième colonne du tableau;

Les plans des pièces détachées sont fournis seulement à titre indicatif et ne représentent pas la pièce concernée.

Les données de ce catalogue sont citées seulement à titre indicatif et peuvent être l'objet de modifications sans avis préalable.

**ESEMPIO
EXAMPLE
EXEMPLE
BEISPIEL**

Rif.	Codici
MODULE:Particolari	
10505	540903
10510	540908
10515	15065/A
10520	540086
10525	540028



Note

Tutte le informazioni riportate si intendono aggiornate alla data di stampa. Il Produttore si riserva il diritto di apportare qualsiasi modifica richiesta dallo sviluppo evolutivo dei suddetti prodotti.

Per la sicurezza, la garanzia, l'affidabilità ed il valore della lavastoviglie usa solo ricambi originali. **Per alcuni codici, sono richieste quantità minime d'ordine.**



Attenzione

Questo libretto è parte integrante della lavastoviglie e, in caso di passaggio di proprietà, deve essere consegnato al nuovo acquirente.



Remarque

Toutes les informations contenues dans ce manuel s'entendent mises à jour à la date d'impression. En raison du développement constant de ses produits, usine se réserve le droit d'apporter à tout instant les modifications qu'elle jugera utiles.

Pour la sécurité, la garantie, la fiabilité et la valeur de votre lavevaisselles n'utilisez que des pièces de rechange d'origine. **Pour quelque référence on demande un minimum de pièces par commande**



Attention

Ce manuel doit être considéré comme partie intégrante de la lavevaisselles, en cas de transfert de propriété, doit toujours être remis au nouveau propriétaire.



Note

The information contained herein is valid at the time of going to print. The Company reserves the right to make any changes required by the future development of the above-mentioned products.

For your safety, as well as to preserve the warranty reliability and worth of your dishwashers, use original spare parts only. **For some codes a minimum quantity for order is required.**



Warning

This manual forms an integral part of the dishwashers and - if a transfer of title occurs - must always be handed over to the new owner.



Hinweis

Die Der Hersteller behält sich das Recht vor, jegliche, durch eine Weiterentwicklung der genannten Produkte bedingte Änderungen vornehmen zu können.

Verwenden Sie für Ihre Sicherheit, die Garantie, die Zuverlässigkeit und den Wert Ihrer machine originale Ersatzteile. **Für bestimmte Code nummer werden mindesten bestellungen verlangt.**



Achtung

Diese Betriebsanleitung ist Bestandteile des machine und muss bei seinem Weiterverkauf dem neuen Besitzer ausgehändigt werden.

vsezip.ru
+7(812)987-08-81

Code DW 999XXYYYY **CL/Part**

Model DESCRIPTION

S/N DW A 1015770 Type

400V 3N 50HZ 8A
3500W 500W

IPX3 16A

Pressione Dinamica alimentazione idrica **200-500 kPa**

Pression dynamique arrivée d'eau

Dynamic pressure water supply

Dynamischer Druck asserreinlauf

Pressione dinamica vapore saturo

Pression dynamique vapore satueèè

Dymanischer Druck gesattigter Dampf

Pression Dinamica Vapor Saturado

TECHICAL SPECIFICATION

MADE IN ITALY

Temperatura massima acqua in ingresso **60°C**

Temperature max eau a l'entre

Maximale Temperatur Wasseranschlü

Maximum Water temperature in-feeding

Model

S/N

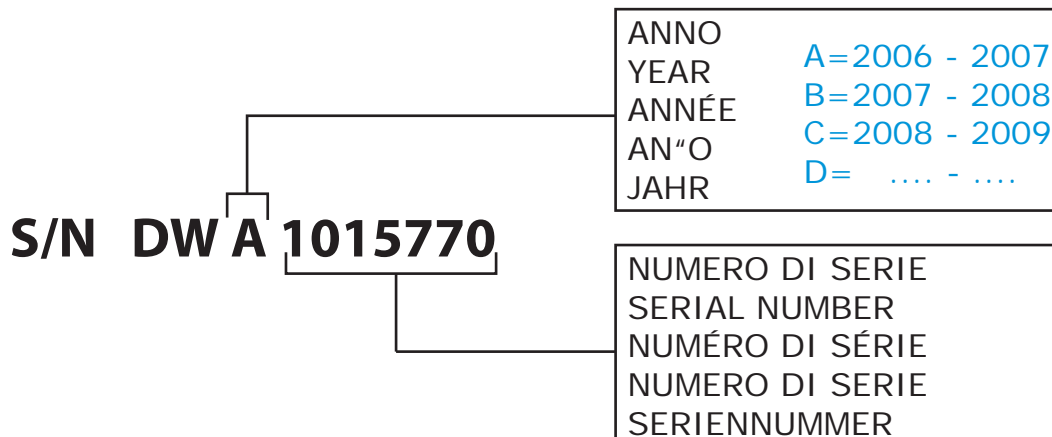
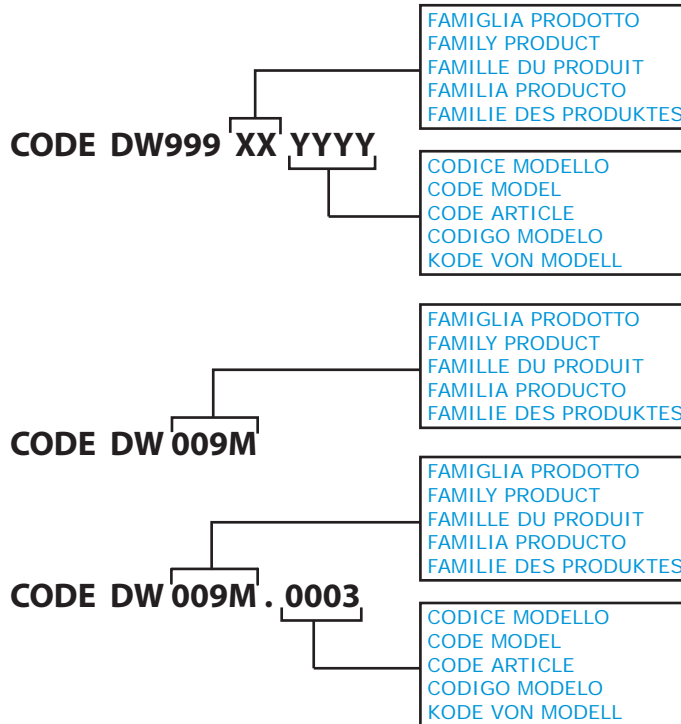

Spare parts

Зип Общепит

vsezip.ru

+7(812)987-08-81

vsezip.ru

+7(812)987-08-81

1. Spare parts

Control Panel ELECTRONIC	7
Electronic control HACCP	9
Electric parts.....	11
General parts	15
Economizer components	17
Curtains group components	19
Solenoid valve group	21
Inverter.....	23
Break Tank	25
Dryer LC70 (6-kW) - part 1	27
Dryer LC70 (6kW) - part 2.....	29
Mecanized curve 90° - LC 77/2	31
Dryer mechanics curve 90° - LC 77/4.	33
Steam condenser / Heat recovery LC71 / TR71 - part	135
Steam condenser / Heat recovery LC71 / TR71 - part	237
DVGW valve	39

Motorgear components	41
Washing components 3+2	43
Rinsing components	45
System components sanitization	47
Internal components	49
Boiler components	53
Conveyor parts	55
Tank insulation	57
Double skin.....	59
Booster pump.....	61
Dispensers SDN-3	63
Angle loading table 90° - LC 98	65
Baskets.....	67
Accessory.....	69

1.1 Voltage codes

Volt	Voltage code
A	3/N/PE~380-400V 50-60Hz
D	3/PE~200-210V 50-60Hz
F	2/PE~220-240V 50-60Hz
G	3/N/PE~415V 50-60Hz
H	3/PE~220-230V 50-60Hz
K	3/PE~380-400V 50-60Hz
L	3/PE~415V 50-60Hz
M	3/PE~440V 60Hz
P	1/N/PE~220-230V 50-60Hz
R	2/PE~220-240V 50-60Hz
U	1/N/PE~240V 50-60Hz
V	3/PE~240V 50-60Hz
W	1/N/PE~100-110V 50-60Hz

1.2 Product codes

Product code	Full name
Model codes	
e	ELECTRONICAL SWITCHES
uw	LOWER AND UPPER WASHER
Type codes	
91	91
Accessory codes	
hr	HEAT RECOVERY - TR71
sc8	STEAM CONDENSER - LC 71
d8	DRYER - LC 70
d8	DRYER - LC 70 - LC 77/4
sz8	SPLASH ZONE - LC 73
ti	TANK INSULATION
ds	DOUBLE SKIN
bp	BOOSTER PUMP
sdn3	DISPENSER SYSTEM SDN-3
sdn4	SANUITIZATION SYSTEM
98	ANGLE LOADING TABLE - LC 98
res	RINSE ECONOMIZER SYSTEM

vsezip.ru

+7(812)987-08-81

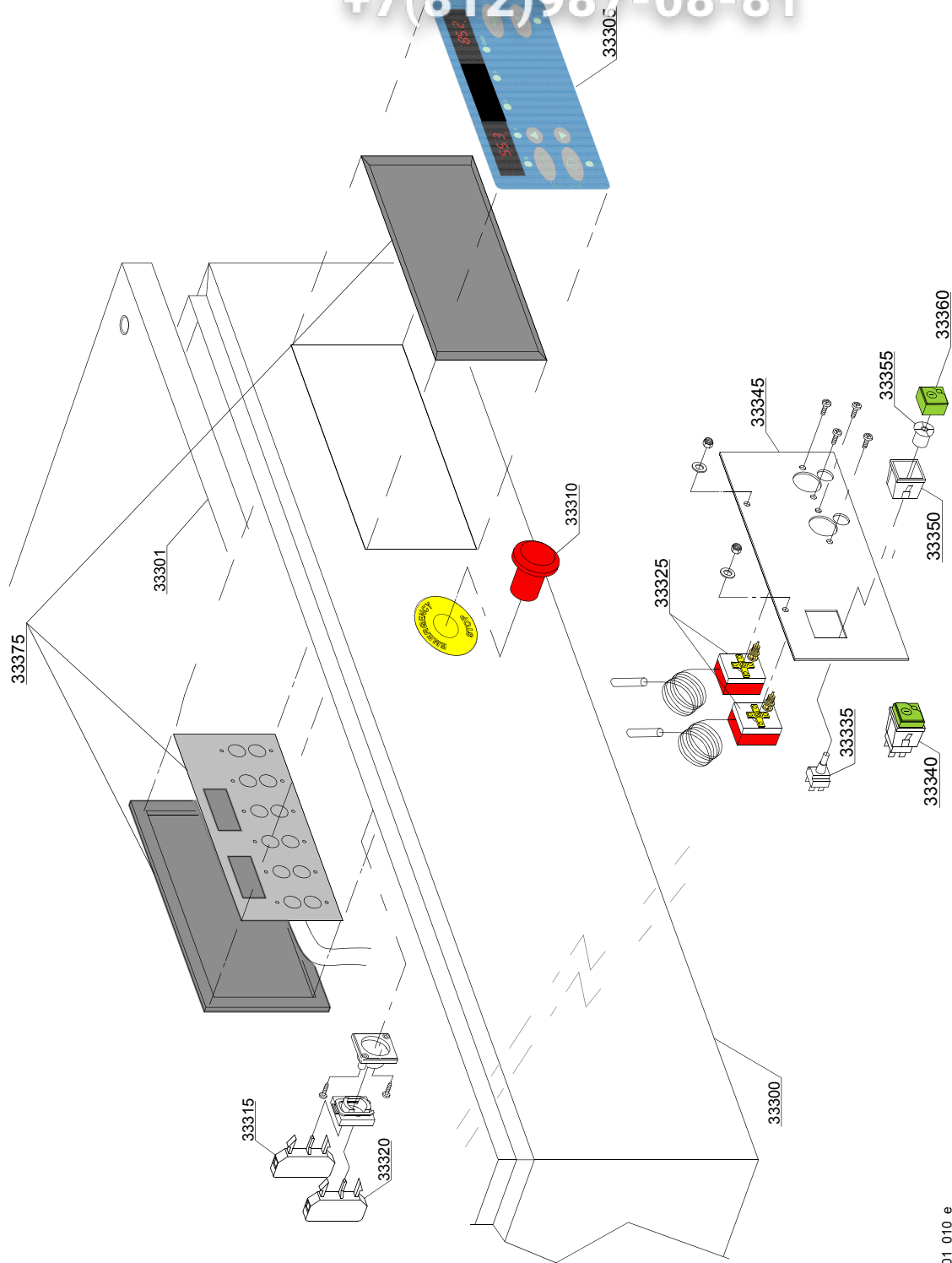

01_010_e

ID	P-code	SN from	SN to	Mod	Acces	Volt	Description
Module: Control Panel ELECTRONIC [161,290,1700,200]							
33300	391072		-	e,uw			Comand parts pannel
33301	391075		-	e,uw			Cover panel
33305	391013		-	e,uw			Control panel (D)
33305	391015		-	e,uw			Control panel (K)
33305	391016		-	e,uw			Control panel (N)
33310	3002050		-	e,uw			Emergency button
33315	3002054		-	e,uw			1NO contact (green)
33320	3002056		-	e,uw			1NC contact (red)
33325	2000430		-	e,uw			Safety thermostat
33335	15812		-	e,uw			Starter electric component
33340	15849		-	e,uw			Switch assembly (PM2)
33345	3009114		-	e,uw			Assembly plate
33350	15815		-	e,uw			Support square single
33355	15824		-	e,uw			Green-orange cam
33360	15874		-	e,uw			Green main switch
33365	3006165		-	e,uw			Termostat probe
33370	3006170		-	e,uw			Extend probe termostat
33375	50570/H		-	e,uw			Main board+ Touche sensitive

em=ELECTROMECHANICAL SWITCHES, e=ELECTRONICAL SWITCHES, uw=LOWER AND UPPER WASHER
91=91

hr=HEAT RECOVERY - TR98, hr=HEAT RECOVERY - TR71, sc8=STEAM CONDENSER - LC 81, sc8=STEAM CONDENSER - LC 71, d9=DRYER - LC 90, sz8=SPLASH ZONE - LC 83, ti=TANK INSULATION, ds=DOUBLE SKIN, bp=BOOSTER PUMP, sdn3=DISPENSER SYSTEM SDN-3, 98=ANGLE LOADING TABLE - LC 98

A=3/N/PE~380-400V 50-60Hz, D=3/PE~200-210V 50-60Hz, F=2/PE~220-240V 50-60Hz, G=3/N/PE~415V 50-60Hz, H=3/PE~220-230V 50-60Hz, K=3/PE~380-400V 50-60Hz, L=3/PE~415V 50-60Hz, M=3/PE~440V 60Hz, P=1/N/PE~220-230V 50-60Hz, R=2/PE~220-240V 50-60Hz, U=1/N/PE~240V 50-60Hz, V=3/PE~240V 50-60Hz, W=1/N/PE~100-110V 50-60Hz

vsezip.ru

+7(812)987-08-81

01_009ae

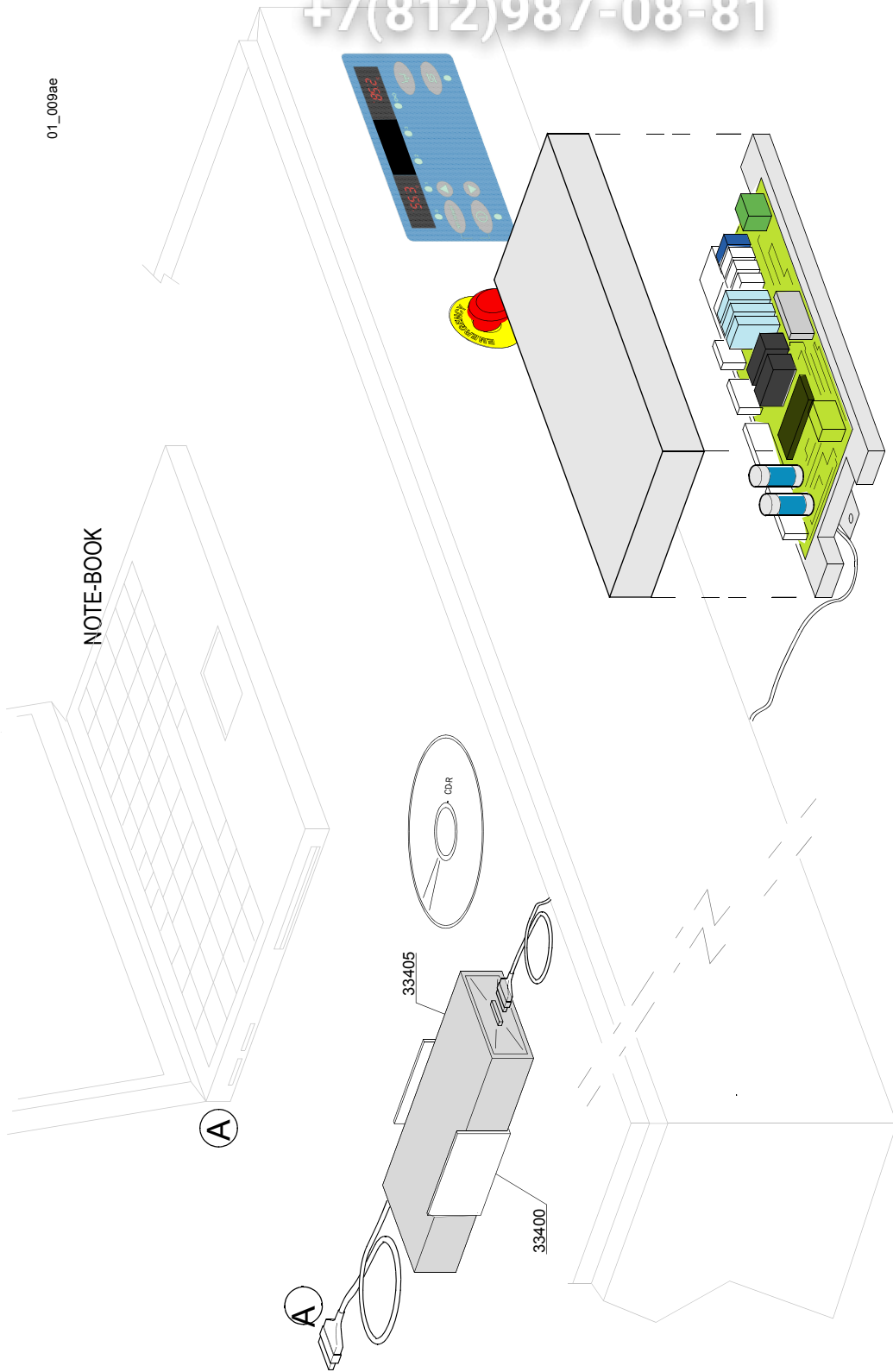

vsezip.ru

ID	P-code	SN from	SN to	Mod.	Acces	Volt	Description
Module:Electronic control HACCP [161,290,170,270]							
33400	3060200		-	e,uw			Support DATA-LOGGER
33405	999910217		-	e,uw			Kit remote control HACCP

em=ELECTROMECHANICAL SWITCHES, e=ELECTRONICAL SWITCHES, uw=LOWER AND UPPER WASHER
91=91

hr=HEAT RECOVERY - TR98, hr=HEAT RECOVERY - TR71, sc8=STEAM CONDENSER - LC 81, sc8=STEAM CONDENSER - LC 71, d9=DRYER - LC 90, sz8=SPLASH ZONE - LC 83, ti=TANK INSULATION, ds=DOUBLE SKIN, bp=BOOSTER PUMP, sdn3=DISPENSER SYSTEM SDN-3, 98=ANGLE LOADING TABLE - LC 98

A=3/N/PE~380-400V 50-60Hz, D=3/PE~200-210V 50-60Hz, F=2/PE~220-240V 50-60Hz, G=3/N/PE~415V 50-60Hz, H=3/PE~220-230V 50-60Hz, K=3/PE~380-400V 50-60Hz, L=3/PE~415V 50-60Hz, M=3/PE~440V 60Hz, P=1/N/PE~220-230V 50-60Hz, R=2/PE~220-240V 50-60Hz, U=1/N/PE~240V 50-60Hz, V=3/PE~240V 50-60Hz, W=1/N/PE~100-110V 50-60Hz

ID	P-code	SN from	SN to	Mod.	Acces.	Volt	Description
Module: Electric parts [161,290,1700,2700]							
1605	15163		-	e,uw		A	Fuse 5x20 1A
1610	2000370		-	e,uw		A	Contacteur MC9
1615	2000380		-	e,uw		A	Contacteur BF12 (heating element < 9 kW)
1615	2000385		-	e,uw		A	Contacteur BF20 (heating element > 9 kW)
1620	2000385		-	e,uw		A	Contacteur BF20
1625	2000393		-	e,uw		A	Motorprotector 1,6 - 2.5A
1625	2000394		-	e,uw		A	Motorprotector 2,5 - 4A
1630	2000389		-	e,uw		A	Motorprotector 0,63- 1A
1630	2000400		-	e,uw		A	Motorprotector 4 - 6.3A
1635	2000403		-	e,uw		A	Automatic fuse C20 (heating element < 9kW)
1635	2000404		-	e,uw		A	Automatic fuse C25 (heating element > 9kW)
1640	2000403		-	e,uw		A	Automatic fuse C20 (heating element < 9kW)
1640	2000408		-	e,uw		A	Automatic fuse 32A
1640	2000404		-	e,uw		A	Automatic fuse C25 (heating element > 9kW)
1645	3006061		-	e,uw		A	Transformer 200VA
1645	3006060		-	e,uw		A	Transformer 160VA
1655	3006078		-	e,uw		A	Relay
1660	3006079		-	e,uw		A	Base for relay
1665	3006080		-	e,uw		A	Auxiliary contact LMS25
1670	3006147		-	e,uw		A	Fuse holder
1675	3006154		-	e,uw		A	Terminal board
1685	391009		-	e,uw		A	Electric parts pannel
1695	3006084		-	e,uw		A	Clamp covering plate RK35
1700	3006155		-	e,uw		A	Clamp 16mm ² BLUE
1705	80419		-	e,uw		A	Cable-fastener PG29
1710	80420		-	e,uw		A	Lock nut
1715	80421		-	e,uw		A	Plug PG29
1720	3006144		-	e,uw		A	Fuse holder covering plate

em=ELECTROMECHANICAL SWITCHES, e=ELECTRONICAL SWITCHES, uw=LOWER AND UPPER WASHER
91=91

hr=HEAT RECOVERY - TR98, hr=HEAT RECOVERY - TR71, sc8=STEAM CONDENSER - LC 81, sc8=STEAM CONDENSER - LC 71, d9=DRYER - LC 90, sz8=SPLASH ZONE - LC 83, ti=TANK INSULATION, ds=DOUBLE SKIN, bp=BOOSTER PUMP, sdn3=DISPENSER SYSTEM SDN-3, 98=ANGLE LOADING TABLE - LC 98

A=3/N/PE~380-400V 50-60Hz, D=3/PE~200-210V 50-60Hz, F=2/PE~220-240V 50-60Hz, G=3/N/PE~415V 50-60Hz, H=3/PE~220-230V 50-60Hz, K=3/PE~380-400V 50-60Hz, L=3/PE~415V 50-60Hz, M=3/PE~440V 60Hz, P=1/N/PE~220-230V 50-60Hz, R=2/PE~220-240V 50-60Hz, U=1/N/PE~240V 50-60Hz, V=3/PE~240V 50-60Hz, W=1/N/PE~100-110V 50-60Hz

vsezip.ru

ID	P-code	SN from	SN to	Mod.	Acces.	Volt	Description
Module:Electric parts [161,290,1700,2700]							
1725	391053/A		-	e,uw		A	Main board+Touche sensitive
1730	3006153		-	e,uw		A	Mechanical lock safety

em=ELECTROMECHANICAL SWITCHES, e=ELECTRONICAL SWITCHES, uw=LOWER AND UPPER WASHER
91=91

hr=HEAT RECOVERY - TR98, hr=HEAT RECOVERY - TR71, sc8=STEAM CONDENSER - LC 81, sc8=STEAM CONDENSER - LC 71, d9=DRYER - LC 90, sz8=SPLASH ZONE - LC 83, ti=TANK INSULATION, ds=DOUBLE SKIN, bp=BOOSTER PUMP, sdn3=DISPENSER SYSTEM SDN-3, 98=ANGLE LOADING TABLE - LC 98

A=3/N/PE~380-400V 50-60Hz, D=3/PE~200-210V 50-60Hz, F=2/PE~220-240V 50-60Hz, G=3/N/PE~415V 50-60Hz, H=3/PE~220-230V 50-60Hz, K=3/PE~380-400V 50-60Hz, L=3/PE~415V 50-60Hz, M=3/PE~440V 60Hz, P=1/N/PE~220-230V 50-60Hz, R=2/PE~220-240V 50-60Hz, U=1/N/PE~240V 50-60Hz, V=3/PE~240V 50-60Hz, W=1/N/PE~100-110V 50-60Hz

vsezip.ru

+7(812)987-08-81

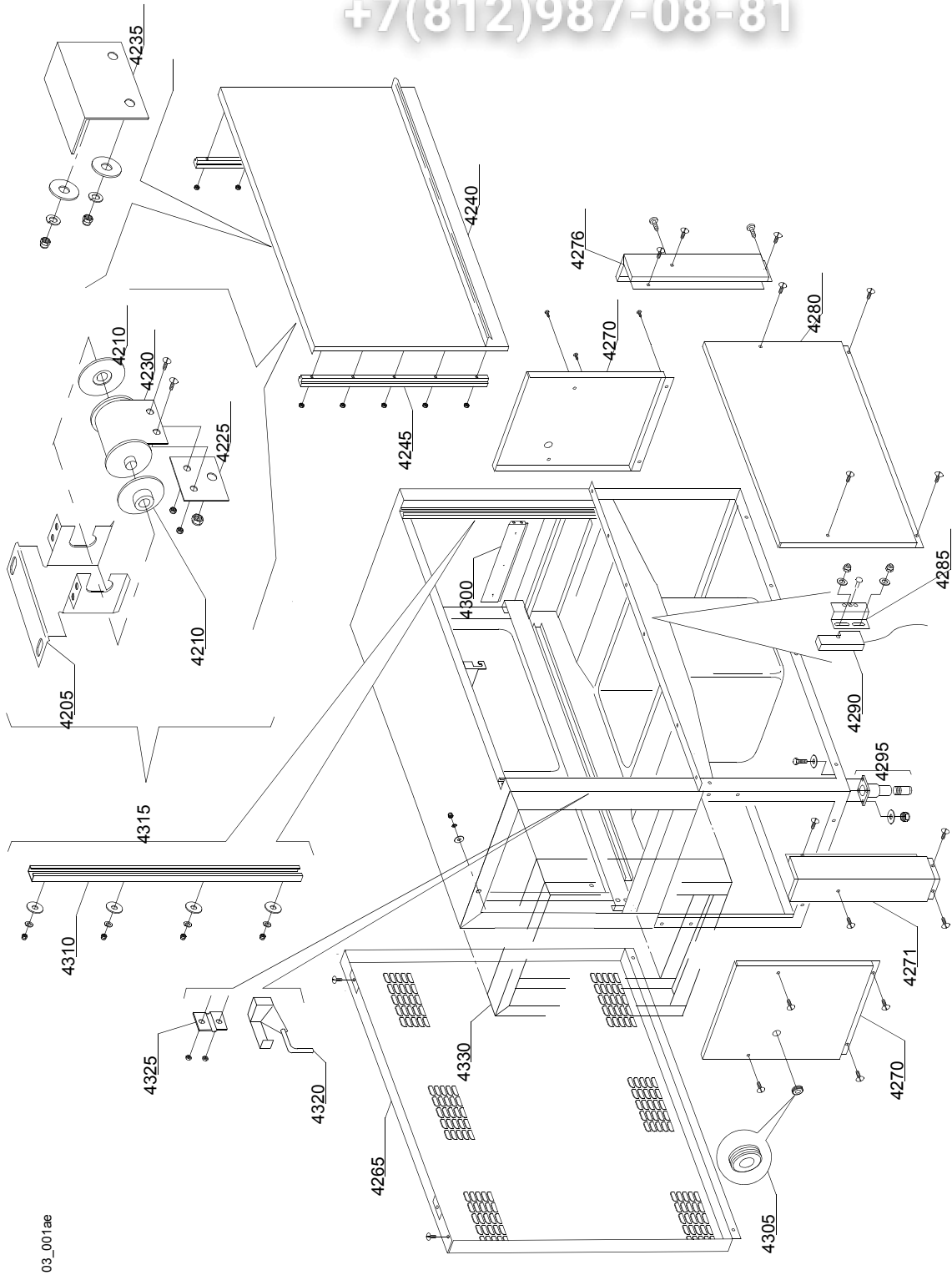

03_001ae

ID	P-code	SN from	SN to	Mod.	Acces.	Volt	Description
Module:General parts [161,1700]							
4205	3009664		-	e,uw			Spring support
4210	3004012		-	e,uw			Spring holder
4225	3009555		-	e,uw			Spring clamping plate
4230	3004010		-	e,uw			Door spring BBSR 21
4235	3009269		-	e,uw			Door stop
4240	391040		-	e,uw			Door assembly
4245	75304		-	e,uw			Door guide
4265	391022		-	e,uw			Rear panel
4270	391021		-	e,uw			Lateral pannel
4280	391020		-	e,uw			Front cover
4285	3009112		-	e,uw			Microswitch support
4290	3003112		-	e,uw			Door microswitch
4295	80116		-	e,uw			Foot
4295	80116/M		-	e,uw			"Marine"Foot
4300	391023		-	e,uw			Side panel
4305	13329		-	e,uw			Fairlead
4310	391039		-	e,uw			Slideways
4315	3009907		-	e,uw			Spring assembly BBSR 21
4320	3000323		-	e,uw			Hook door
4325	3000324		-	e,uw			Hook support
4330	391050		-	e,uw			Splash guard

em=ELECTROMECHANICAL SWITCHES, e=ELECTRONICAL SWITCHES, uw=LOWER AND UPPER WASHER
91=91

hr=HEAT RECOVERY - TR98, hr=HEAT RECOVERY - TR71, sc8=STEAM CONDENSER - LC 81, sc8=STEAM CONDENSER - LC 71, d9=DRYER - LC 90, sz8=SPLASH ZONE - LC 83, ti=TANK INSULATION, ds=DOUBLE SKIN, bp=BOOSTER PUMP, sdn3=DISPENSER SYSTEM SDN-3, 98=ANGLE LOADING TABLE - LC 98

A=3/N/PE~380-400V 50-60Hz, D=3/PE~200-210V 50-60Hz, F=2/PE~220-240V 50-60Hz, G=3/N/PE~415V 50-60Hz, H=3/PE~220-230V 50-60Hz, K=3/PE~380-400V 50-60Hz, L=3/PE~415V 50-60Hz, M=3/PE~440V 60Hz, P=1/N/PE~220-230V 50-60Hz, R=2/PE~220-240V 50-60Hz, U=1/N/PE~240V 50-60Hz, V=3/PE~240V 50-60Hz, W=1/N/PE~100-110V 50-60Hz

03_102be

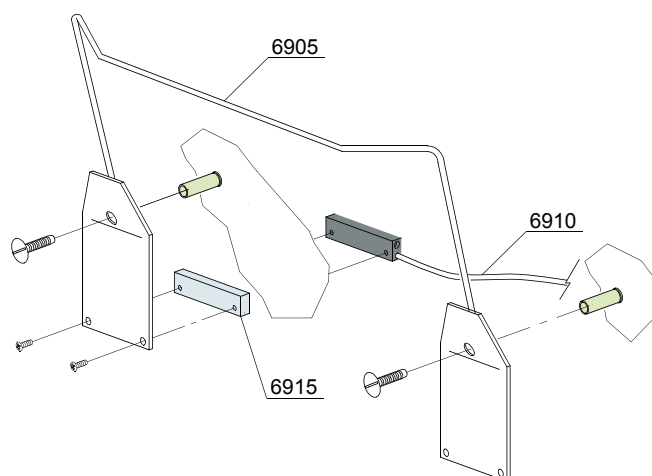
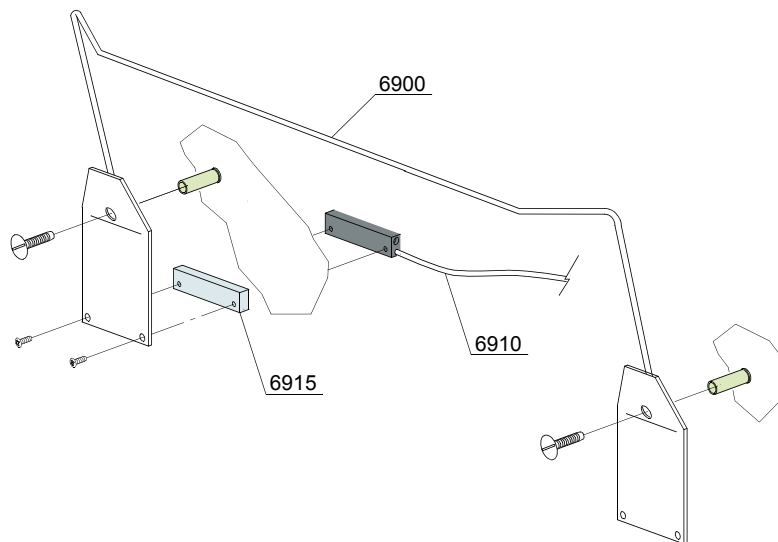

vsezip.ru

ID	P-code	SN from	SN to	Mod.	Acces.	Volt	Description
Module: Economizer components [161,1700]							
6900	391044		-	e,uw			Rack switch wash
6905	391047		-	e,uw			Rack switch rinsing
6910	10778		-	e,uw			Door microswitch
6915	391046		-	e,uw			Magnet

em=ELECTROMECHANICAL SWITCHES, e=ELECTRONICAL SWITCHES, uw=LOWER AND UPPER WASHER
91=91

hr=HEAT RECOVERY - TR98, hr=HEAT RECOVERY - TR71, sc8=STEAM CONDENSER - LC 81, sc8=STEAM CONDENSER - LC 71, d9=DRYER - LC 90, sz8=SPLASH ZONE - LC 83, ti=TANK INSULATION, ds=DOUBLE SKIN, bp=BOOSTER PUMP, sdn3=DISPENSER SYSTEM SDN-3, 98=ANGLE LOADING TABLE - LC 98

A=3/N/PE~380-400V 50-60Hz, D=3/PE~200-210V 50-60Hz, F=2/PE~220-240V 50-60Hz, G=3/N/PE~415V 50-60Hz, H=3/PE~220-230V 50-60Hz, K=3/PE~380-400V 50-60Hz, L=3/PE~415V 50-60Hz, M=3/PE~440V 60Hz, P=1/N/PE~220-230V 50-60Hz, R=2/PE~220-240V 50-60Hz, U=1/N/PE~240V 50-60Hz, V=3/PE~240V 50-60Hz, W=1/N/PE~100-110V 50-60Hz

vsezip.ru

+7(812)987-08-81

03_201_e

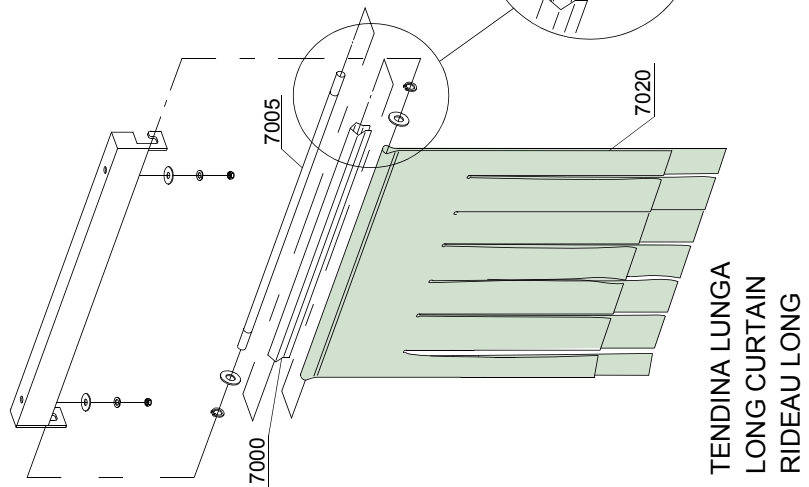
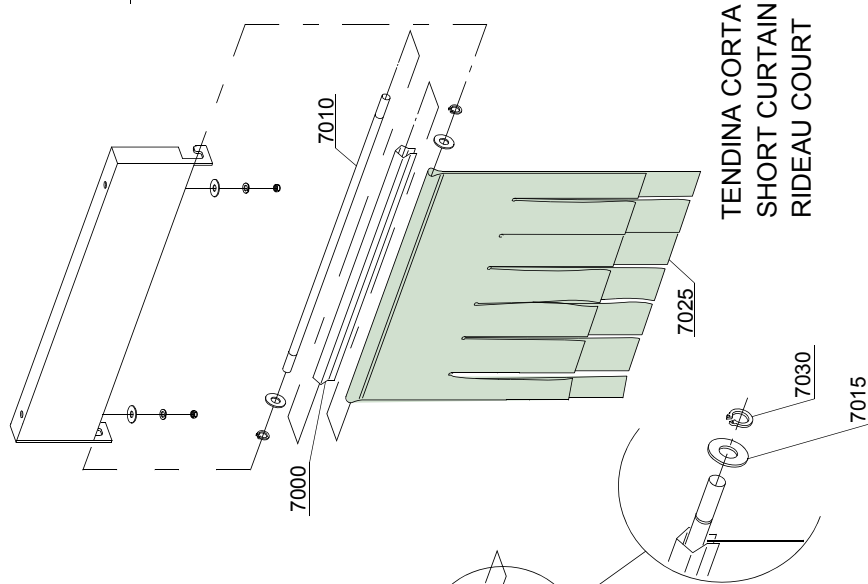
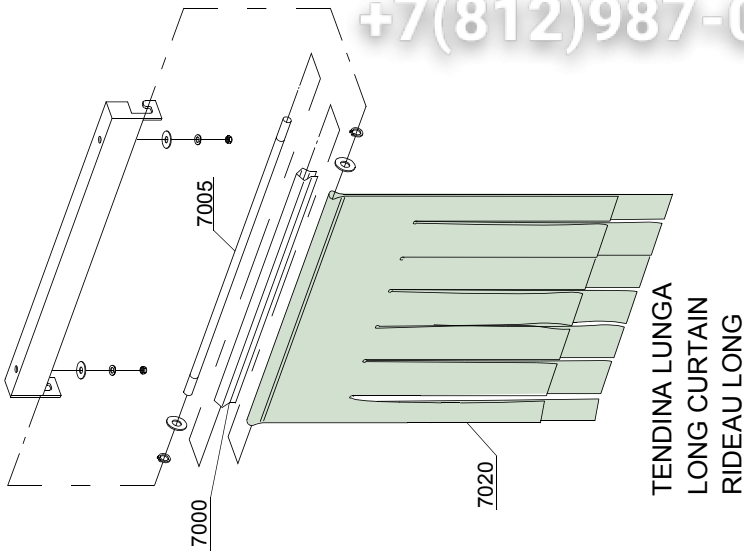

vsezip.ru

ID	P-code	SN from	SN to	Mod.	Acces.	Volt	Description
Module: Curtains group components [161,290,1700,2700]							
7000	3009109		-	e,uw			Curtain moulding
7005	3004052		-	e,uw			Curtain rod long
7010	391038		-	e,uw			Curtain inner rod short
7015	11185		-	e,uw			Flat washer 8x16 inox
7020	3004051		-	e,uw			Curtain long
7025	391037		-	e,uw			Curtain short
7030	11815		-	e,uw			Sege Ø 8 inox

em=ELECTROMECHANICAL SWITCHES, e=ELECTRONICAL SWITCHES, uw=LOWER AND UPPER WASHER
91=91

hr=HEAT RECOVERY - TR98, hr=HEAT RECOVERY - TR71, sc8=STEAM CONDENSER - LC 81, sc8=STEAM CONDENSER - LC 71, d9=DRYER - LC 90, sz8=SPLASH ZONE - LC 83, ti=TANK INSULATION, ds=DOUBLE SKIN, bp=BOOSTER PUMP, sdn3=DISPENSER SYSTEM SDN-3, 98=ANGLE LOADING TABLE - LC 98

A=3/N/PE~380-400V 50-60Hz, D=3/PE~200-210V 50-60Hz, F=2/PE~220-240V 50-60Hz, G=3/N/PE~415V 50-60Hz, H=3/PE~220-230V 50-60Hz, K=3/PE~380-400V 50-60Hz, L=3/PE~415V 50-60Hz, M=3/PE~440V 60Hz, P=1/N/PE~220-230V 50-60Hz, R=2/PE~220-240V 50-60Hz, U=1/N/PE~240V 50-60Hz, V=3/PE~240V 50-60Hz, W=1/N/PE~100-110V 50-60Hz

05_003_e

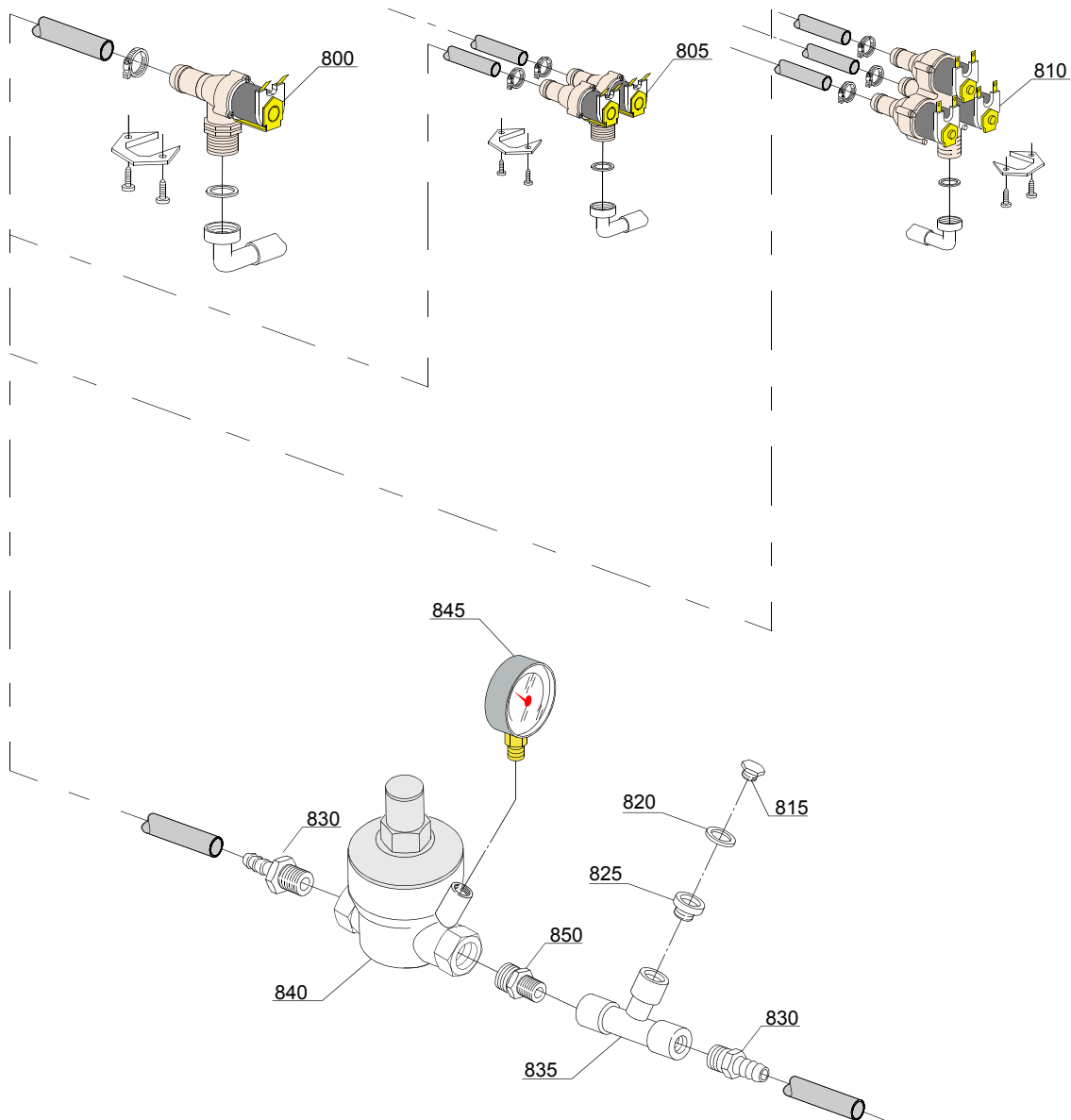

ID	P-code	SN from	SN to	Mod.	Acces.	Volt	Description
Module: Solenoid valve group [161,290,1700,2700]							
800	2000093		-	e,uw			Single solenoid valve - Ø14 3/4"
805	2000094		-	e,uw			Double solenoid valve - Ø14 3/4"
810	2000095		-	e,uw			Triple solenoid valve - Ø14 3/4"
815	12002		-	e,uw			Plug
820	13309		-	e,uw			Gasket 14x10x1,5
825	12032		-	e,uw			Reduction nipples
830	12005		-	e,uw			Hose holder
835	12008		-	e,uw			Connection "T"
840	391025		-	e,uw			Pressure reduction valve
845	2000244		-	e,uw			Pressure reduction gauge
850	12033		-	e,uw			1/4M - 1/2 Reduction nipples

em=ELECTROMECHANICAL SWITCHES, e=ELECTRONICAL SWITCHES, uw=LOWER AND UPPER WASHER
91=91

hr=HEAT RECOVERY - TR98, hr=HEAT RECOVERY - TR71, sc8=STEAM CONDENSER - LC 81, sc8=STEAM CONDENSER - LC 71, d9=DRYER - LC 90, sz8=SPLASH ZONE - LC 83, ti=TANK INSULATION, ds=DOUBLE SKIN, bp=BOOSTER PUMP, sdn3=DISPENSER SYSTEM SDN-3, 98=ANGLE LOADING TABLE - LC 98

A=3/N/PE~380-400V 50-60Hz, D=3/PE~200-210V 50-60Hz, F=2/PE~220-240V 50-60Hz, G=3/N/PE~415V 50-60Hz, H=3/PE~220-230V 50-60Hz, K=3/PE~380-400V 50-60Hz, L=3/PE~415V 50-60Hz, M=3/PE~440V 60Hz, P=1/N/PE~220-230V 50-60Hz, R=2/PE~220-240V 50-60Hz, U=1/N/PE~240V 50-60Hz, V=3/PE~240V 50-60Hz, W=1/N/PE~100-110V 50-60Hz

vsezip.ru

+7(812)987-08-81

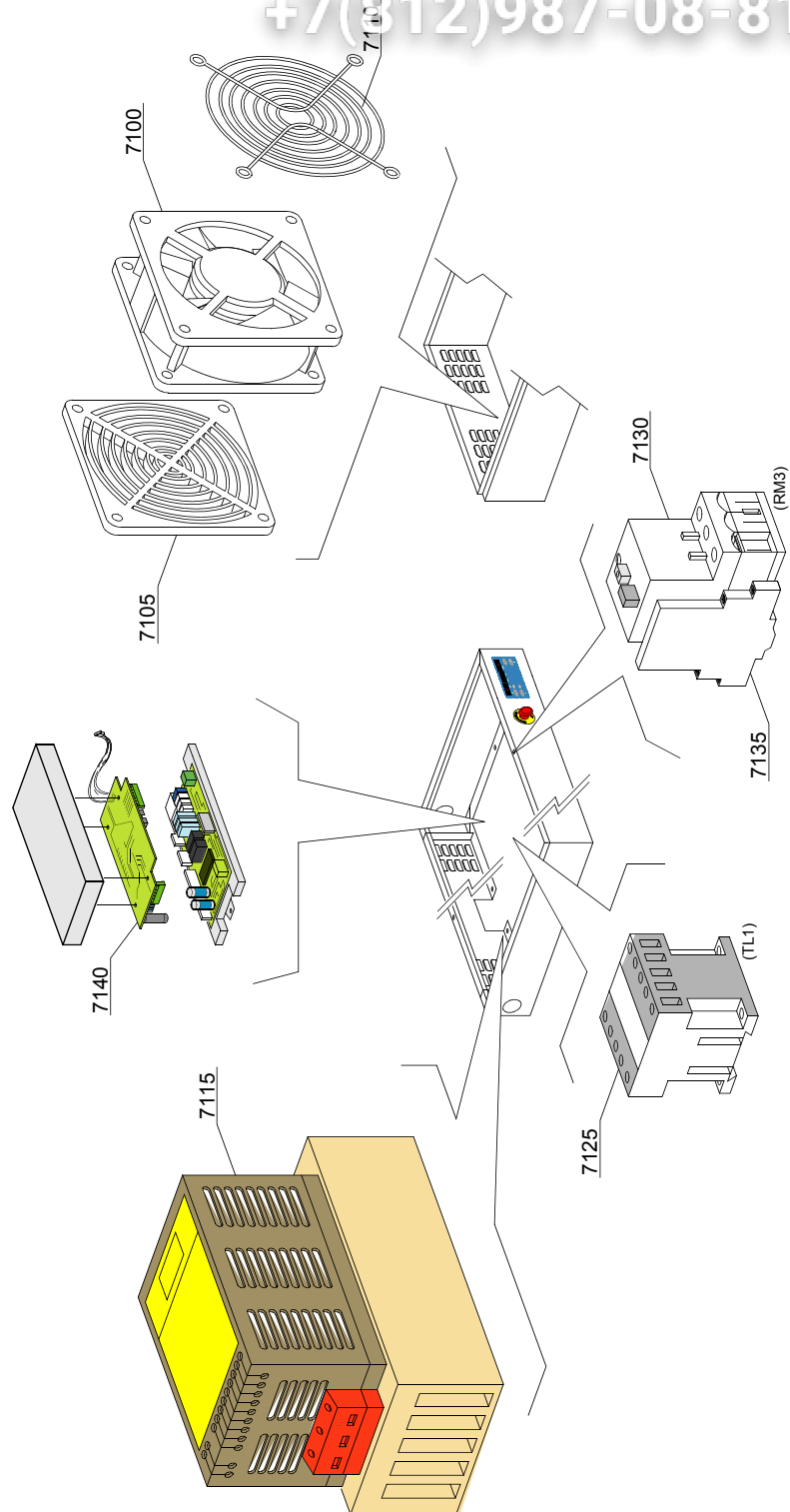

06_001_e

vsezip.ru

ID	P-code	SN from	SN to	Mod.	Acces.	Volt	Description
Module: Inverter [161,290,1700,2700]							
7100	3000118		-	e,uw			Impeller fan
7105	3000118/A		-	e,uw			Filter
7110	3000118/B		-	e,uw			Grid
7115	3000117		-	e,uw			Inverter 0,37kW
7125	2000370		-	e,uw			Contactora MC9
7130	2000400		-	e,uw			Motorprotector 4-6,3A
7135	3006080		-	e,uw			Auxiliary contact LMS25
7140	391064		-	e,uw			EXP card sanitization

em=ELECTROMECHANICAL SWITCHES, e=ELECTRONICAL SWITCHES, uw=LOWER AND UPPER WASHER
91=91

hr=HEAT RECOVERY - TR98, hr=HEAT RECOVERY - TR71, sc8=STEAM CONDENSER - LC 81, sc8=STEAM CONDENSER - LC 71, d9=DRYER - LC 90, sz8=SPLASH ZONE - LC 83, ti=TANK INSULATION, ds=DOUBLE SKIN, bp=BOOSTER PUMP, sdn3=DISPENSER SYSTEM SDN-3, 98=ANGLE LOADING TABLE - LC 98

A=3/N/PE~380-400V 50-60Hz, D=3/PE~200-210V 50-60Hz, F=2/PE~220-240V 50-60Hz, G=3/N/PE~415V 50-60Hz, H=3/PE~220-230V 50-60Hz, K=3/PE~380-400V 50-60Hz, L=3/PE~415V 50-60Hz, M=3/PE~440V 60Hz, P=1/N/PE~220-230V 50-60Hz, R=2/PE~220-240V 50-60Hz, U=1/N/PE~240V 50-60Hz, V=3/PE~240V 50-60Hz, W=1/N/PE~100-110V 50-60Hz

vsezip.ru

+7(812)987-08-81

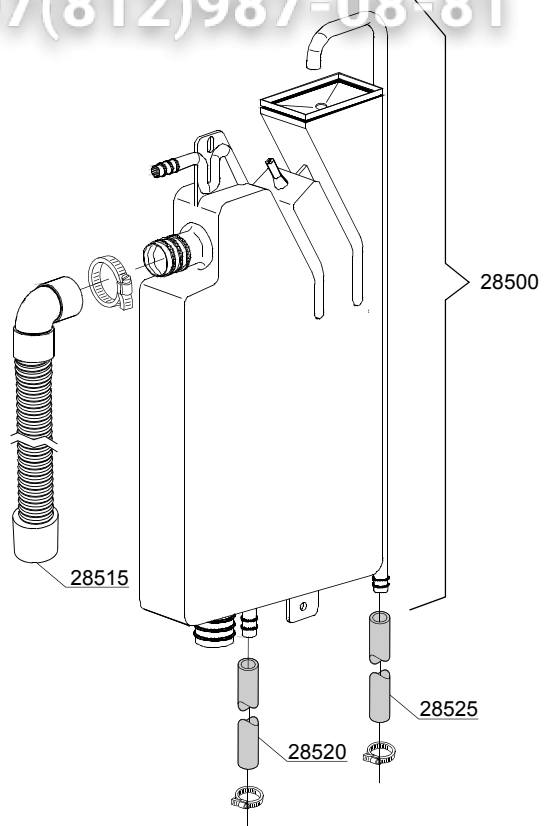

06_004ae

vsezip.ru

ID	P-code	SN from	SN to	Mod.	Acces.	Volt	Description
Module:Break Tank [161,290,1700,2700]							
28500	15720		-	e,uw			Break tank assembly
28515	15721		-	e,uw			BT long pipe L=1070
28515	15722		-	e,uw			BT middle pipe L=920
28515	15723		-	e,uw			BT small pipe L=690
28520	2907350		-	e,uw			12x20 EPDM rubber hose
28525	2907352		-	e,uw			PVC WRAS rubber hose

em=ELECTROMECHANICAL SWITCHES, e=ELECTRONICAL SWITCHES, uw=LOWER AND UPPER WASHER
91=91

hr=HEAT RECOVERY - TR98, hr=HEAT RECOVERY - TR71, sc8=STEAM CONDENSER - LC 81, sc8=STEAM CONDENSER - LC 71, d9=DRYER - LC 90, sz8=SPLASH ZONE - LC 83, ti=TANK INSULATION, ds=DOUBLE SKIN, bp=BOOSTER PUMP, sdn3=DISPENSER SYSTEM SDN-3, 98=ANGLE LOADING TABLE - LC 98

A=3/N/PE~380-400V 50-60Hz, D=3/PE~200-210V 50-60Hz, F=2/PE~220-240V 50-60Hz, G=3/N/PE~415V 50-60Hz, H=3/PE~220-230V 50-60Hz, K=3/PE~380-400V 50-60Hz, L=3/PE~415V 50-60Hz, M=3/PE~440V 60Hz, P=1/N/PE~220-230V 50-60Hz, R=2/PE~220-240V 50-60Hz, U=1/N/PE~240V 50-60Hz, V=3/PE~240V 50-60Hz, W=1/N/PE~100-110V 50-60Hz

vsezip.ru

+7(812)987-08-81

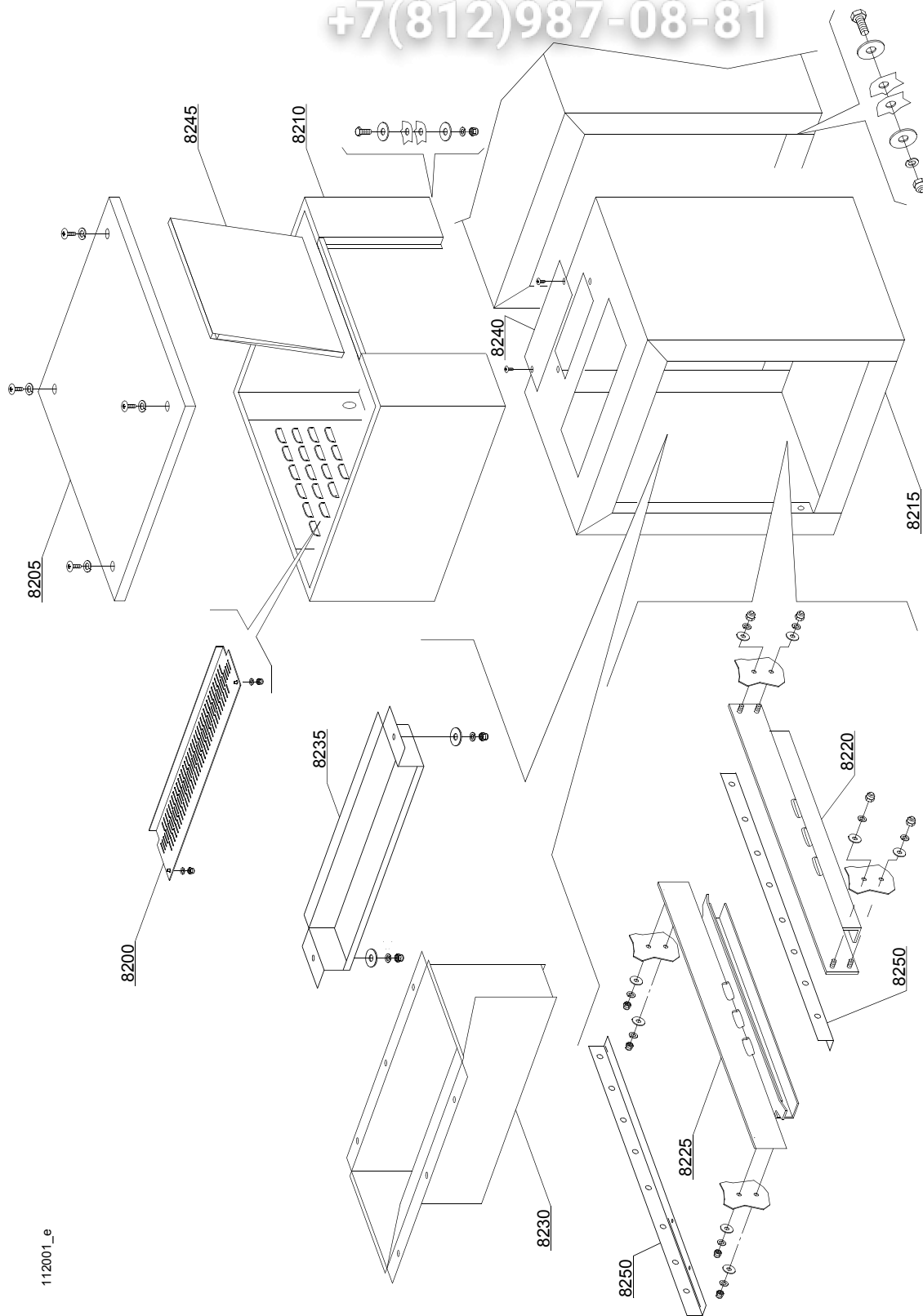

112001_e

vsezip.ru

ID	P-code	SN from	SN to	Mod.	Acces.	Volt	Description
Module: Dryer LC70 (6-kW) - part 1 [161,290,1700,2700]							
8200	392021		-	e,uw			Protection
8205	392024		-	e,uw			Cover panel
8210	392026		-	e,uw			Complete body
8215	392020		-	e,uw			Dryer module
8220	392019		-	e,uw			Front slideways
8225	392019		-	e,uw			Back slideways
8230	392037		-	e,uw			Flow conveyer
8235	3009540		-	e,uw			Splash guard
8240	3009300		-	e,uw			Air covering
8245	392023		-	e,uw			Dryer carter lockup
8250	391059		-	e,uw			Mobile chassis

em=ELECTROMECHANICAL SWITCHES, e=ELECTRONICAL SWITCHES, uw=LOWER AND UPPER WASHER
91=91

hr=HEAT RECOVERY - TR98, hr=HEAT RECOVERY - TR71, sc8=STEAM CONDENSER - LC 81, sc8=STEAM CONDENSER - LC 71, d9=DRYER - LC 90, sz8=SPLASH ZONE - LC 83, ti=TANK INSULATION, ds=DOUBLE SKIN, bp=BOOSTER PUMP, sdn3=DISPENSER SYSTEM SDN-3, 98=ANGLE LOADING TABLE - LC 98

A=3/N/PE~380-400V 50-60Hz, D=3/PE~200-210V 50-60Hz, F=2/PE~220-240V 50-60Hz, G=3/N/PE~415V 50-60Hz, H=3/PE~220-230V 50-60Hz, K=3/PE~380-400V 50-60Hz, L=3/PE~415V 50-60Hz, M=3/PE~440V 60Hz, P=1/N/PE~220-230V 50-60Hz, R=2/PE~220-240V 50-60Hz, U=1/N/PE~240V 50-60Hz, V=3/PE~240V 50-60Hz, W=1/N/PE~100-110V 50-60Hz

vsezip.ru

+7(812)987-08-81

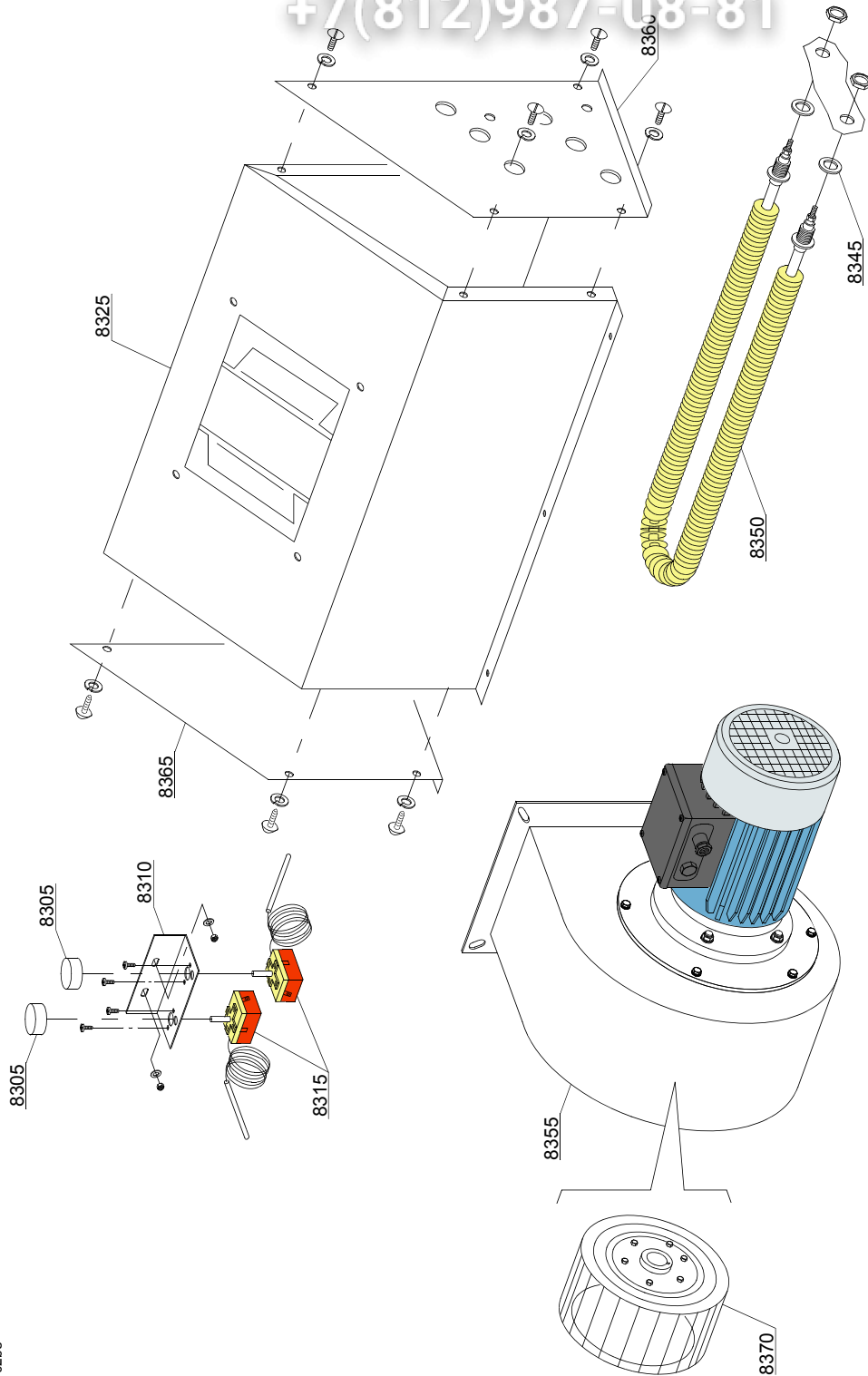

11_102be

vsezip.ru

ID	P-code	SN from	SN to	Mod.	Acces.	Volt	Description
Module: Dryer LC70 (6kW) - part 2 [161,290,1700,2700]							
8305	15105/C		-	e,uw			0-300°C Thermostat knob
8310	3009104		-	e,uw			Thermostat support
8315	10707/3		-	e,uw			Thermostat with shaft 0 - 300°
8325	3009674		-	e,uw			Drying Carter
8345	10200171		-	e,uw			Gasket FASIT 25x17x2
8350	2000359		-	e,uw			Drying heating element with nut
8355	3000313		-	e,uw			Motorfan 0,55 kW 60-Hz
8355	3000300		-	e,uw			Motorfan 0,55 kW
8360	3009675		-	e,uw			Side with oles
8365	3009676		-	e,uw			Side without oles
8370	3000308		-	e,uw			Pump rotor

em=ELECTROMECHANICAL SWITCHES, e=ELECTRONICAL SWITCHES, uw=LOWER AND UPPER WASHER
91=91

hr=HEAT RECOVERY - TR98, hr=HEAT RECOVERY - TR71, sc8=STEAM CONDENSER - LC 81, sc8=STEAM CONDENSER - LC 71, d9=DRYER - LC 90, sz8=SPLASH ZONE - LC 83, ti=TANK INSULATION, ds=DOUBLE SKIN, bp=BOOSTER PUMP, sdn3=DISPENSER SYSTEM SDN-3, 98=ANGLE LOADING TABLE - LC 98

A=3/N/PE~380-400V 50-60Hz, D=3/PE~200-210V 50-60Hz, F=2/PE~220-240V 50-60Hz, G=3/N/PE~415V 50-60Hz, H=3/PE~220-230V 50-60Hz, K=3/PE~380-400V 50-60Hz, L=3/PE~415V 50-60Hz, M=3/PE~440V 60Hz, P=1/N/PE~220-230V 50-60Hz, R=2/PE~220-240V 50-60Hz, U=1/N/PE~240V 50-60Hz, V=3/PE~240V 50-60Hz, W=1/N/PE~100-110V 50-60Hz

15_102ae

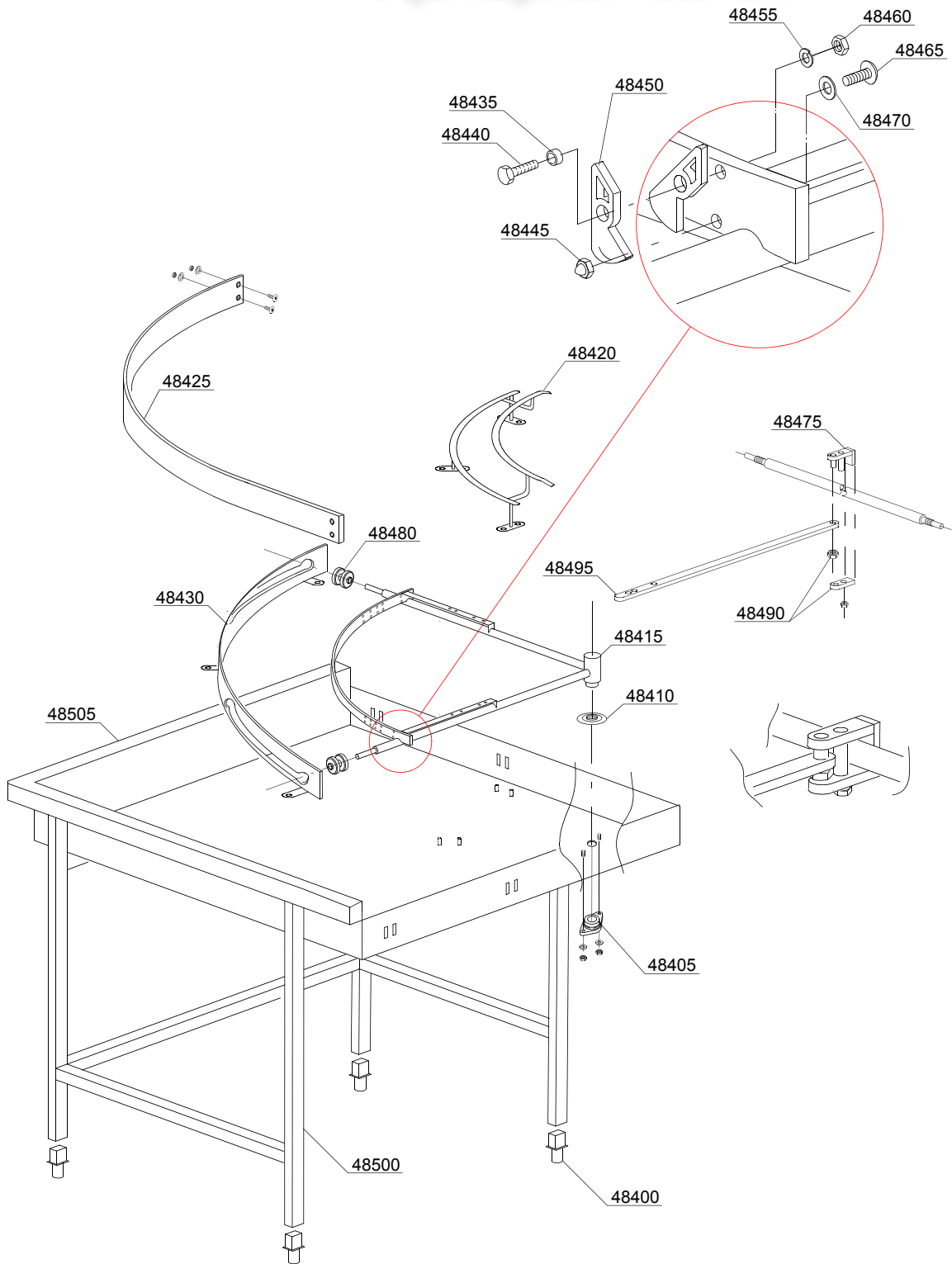

ID	P-code	SN from	SN to	Mod.	Acces	Volt	Description
Module:Mecanized curve 90° - LC 77/2 [161,290,1700,2700]							
48400	3000352		-	e,uw			Adjustable food
48405	3000260		-	e,uw			Flange
48410	3004161		-	e,uw			Protection disk
48415	3063006		-	e,uw			Center transport
48420	3063002		-	e,uw			Inside support basket
48425	3063003		-	e,uw			External support basket
48430	3063005		-	e,uw			Center support guide assembly
48435	3003025		-	e,uw			11,7x10x6 Bush
48440	11109		-	e,uw			M10x20 inox screw
48445	11707		-	e,uw			M5 inox nut
48450	3063009		-	e,uw			Inox Clip
48455	11609		-	e,uw			M8 inox washer
48460	11719		-	e,uw			M10 inox nut
48465	11197		-	e,uw			M5x10 inox screw
48470	11608		-	e,uw			M5 inox washer
48475	3063008		-	e,uw			Axis machine coupling
48480	3063007		-	e,uw			Wheel
48490	3063010		-	e,uw			Axle machine coupling lock nut
48495	3063004		-	e,uw			Machine connectin rod
48500	3063001		-	e,uw			Mecanized curve chassis
48505	3063000		-	e,uw			Mecanized curve base

em=ELECTROMECHANICAL SWITCHES, e=ELECTRONICAL SWITCHES, uw=LOWER AND UPPER WASHER
91=91

hr=HEAT RECOVERY - TR98, hr=HEAT RECOVERY - TR71, sc8=STEAM CONDENSER - LC 81, sc8=STEAM CONDENSER - LC 71, d9=DRYER - LC 90, sz8=SPLASH ZONE - LC 83, ti=TANK INSULATION, ds=DOUBLE SKIN, bp=BOOSTER PUMP, sdn3=DISPENSER SYSTEM SDN-3, 98=ANGLE LOADING TABLE - LC 98

A=3/N/PE~380-400V 50-60Hz, D=3/PE~200-210V 50-60Hz, F=2/PE~220-240V 50-60Hz, G=3/N/PE~415V 50-60Hz, H=3/PE~220-230V 50-60Hz, K=3/PE~380-400V 50-60Hz, L=3/PE~415V 50-60Hz, M=3/PE~440V 60Hz, P=1/N/PE~220-230V 50-60Hz, R=2/PE~220-240V 50-60Hz, U=1/N/PE~240V 50-60Hz, V=3/PE~240V 50-60Hz, W=1/N/PE~100-110V 50-60Hz

vsezip.ru

+7(812)987-08-81

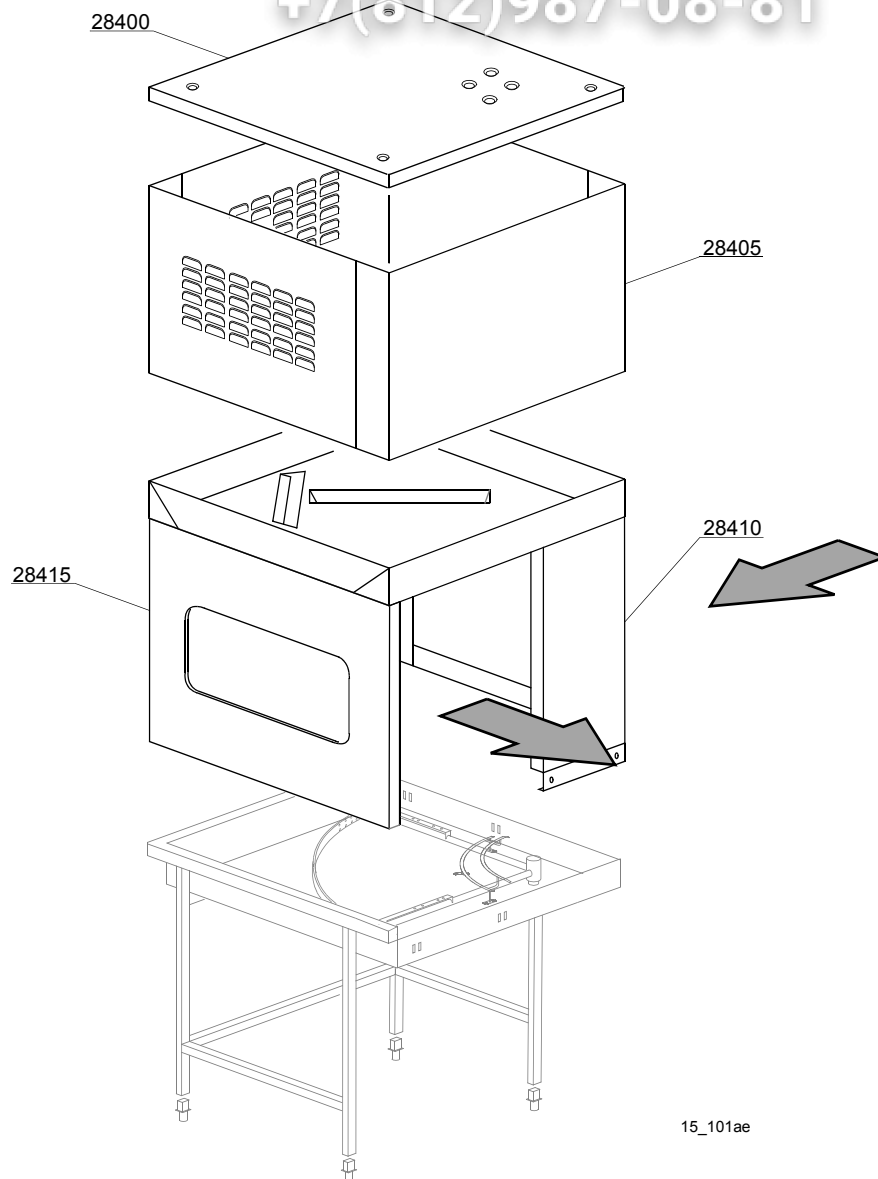

15_101ae

vsezip.ru

ID	P-code	SN from	SN to	Mod.	Acces.	Volt	Description
Module: Dryer mechanics curve 90° - LC 77/4 [161,290,170,2700]							
28400	3009710		-	e,uw			Cover panel
28405	3009511		-	e,uw			Carter
28410	3009709		-	e,uw			Dryer column mechanics curve
28415	3009708		-	e,uw			Dryer mechanics plating 90°

em=ELECTROMECHANICAL SWITCHES, e=ELECTRONICAL SWITCHES, uw=LOWER AND UPPER WASHER
91=91

hr=HEAT RECOVERY - TR98, hr=HEAT RECOVERY - TR71, sc8=STEAM CONDENSER - LC 81, sc8=STEAM CONDENSER - LC 71, d9=DRYER - LC 90, sz8=SPLASH ZONE - LC 83, ti=TANK INSULATION, ds=DOUBLE SKIN, bp=BOOSTER PUMP, sdn3=DISPENSER SYSTEM SDN-3, 98=ANGLE LOADING TABLE - LC 98

A=3/N/PE~380-400V 50-60Hz, D=3/PE~200-210V 50-60Hz, F=2/PE~220-240V 50-60Hz, G=3/N/PE~415V 50-60Hz, H=3/PE~220-230V 50-60Hz, K=3/PE~380-400V 50-60Hz, L=3/PE~415V 50-60Hz, M=3/PE~440V 60Hz, P=1/N/PE~220-230V 50-60Hz, R=2/PE~220-240V 50-60Hz, U=1/N/PE~240V 50-60Hz, V=3/PE~240V 50-60Hz, W=1/N/PE~100-110V 50-60Hz

17_002_e

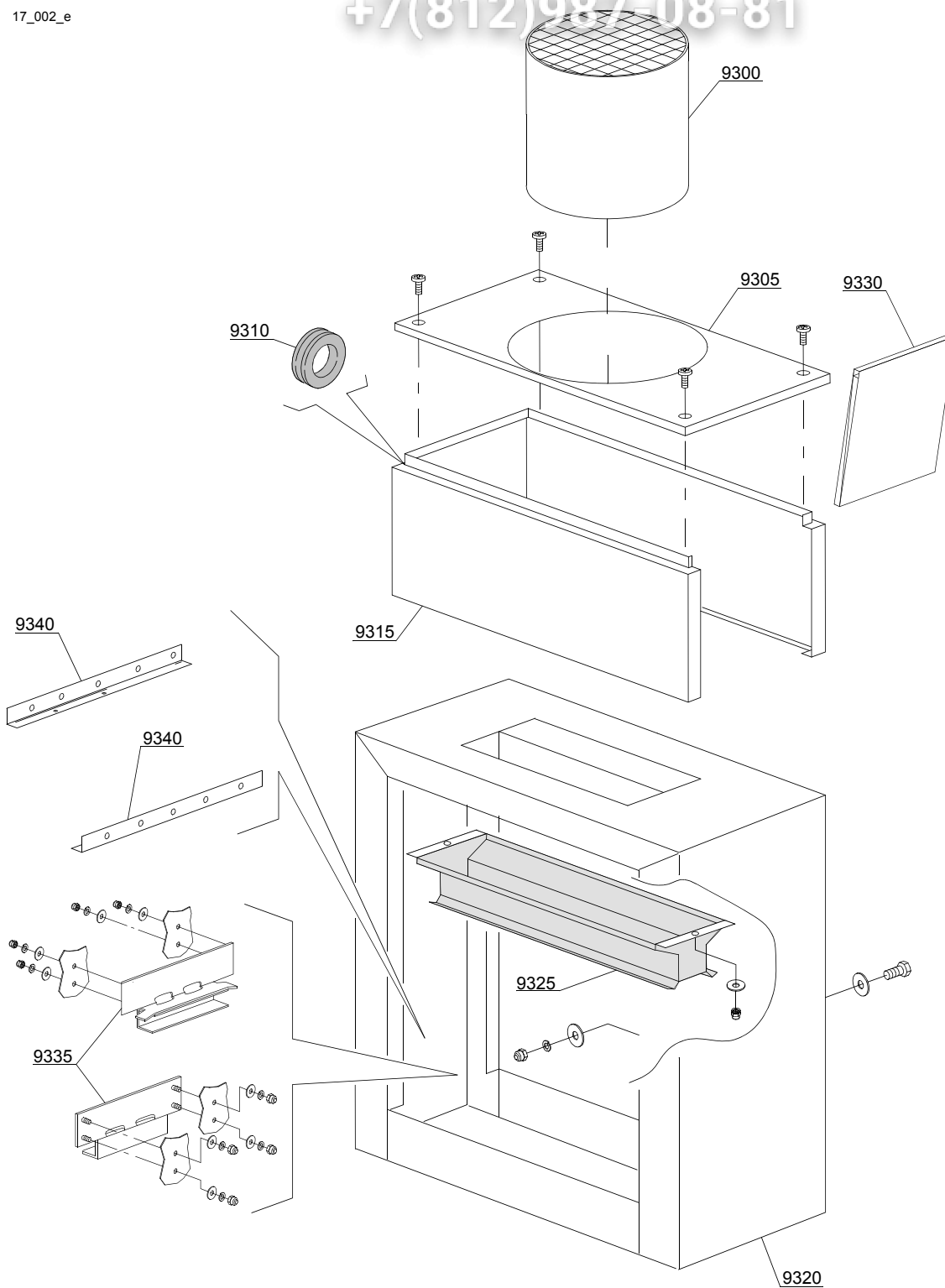

vsezip.ru

ID	P-code	SN from	SN to	Mod.	Acces.	Volt	Description
Module: Steam condenser / Heat recovery LC71 / TR70 - part 1 [61,290,1700,2700]							
9300	3009573		-	e,uw			Chimney
9305	392035		-	e,uw			Cover with hole
9310	13329		-	e,uw			Fairlead
9315	392034		-	e,uw			Complete body
9320	392030		-	e,uw			Jet top
9325	3009543		-	e,uw			Suction group
9330	392031		-	e,uw			Carter lockup
9335	392029		-	e,uw			Front / back slideways
9340	391058		-	e,uw			Mobile chassis

em=ELECTROMECHANICAL SWITCHES, e=ELECTRONICAL SWITCHES, uw=LOWER AND UPPER WASHER
91=91

hr=HEAT RECOVERY - TR98, hr=HEAT RECOVERY - TR71, sc8=STEAM CONDENSER - LC 81, sc8=STEAM CONDENSER - LC 71, d9=DRYER - LC 90, sz8=SPLASH ZONE - LC 83, ti=TANK INSULATION, ds=DOUBLE SKIN, bp=BOOSTER PUMP, sdn3=DISPENSER SYSTEM SDN-3, 98=ANGLE LOADING TABLE - LC 98

A=3/N/PE~380-400V 50-60Hz, D=3/PE~200-210V 50-60Hz, F=2/PE~220-240V 50-60Hz, G=3/N/PE~415V 50-60Hz, H=3/PE~220-230V 50-60Hz, K=3/PE~380-400V 50-60Hz, L=3/PE~415V 50-60Hz, M=3/PE~440V 60Hz, P=1/N/PE~220-230V 50-60Hz, R=2/PE~220-240V 50-60Hz, U=1/N/PE~240V 50-60Hz, V=3/PE~240V 50-60Hz, W=1/N/PE~100-110V 50-60Hz

17_102_e

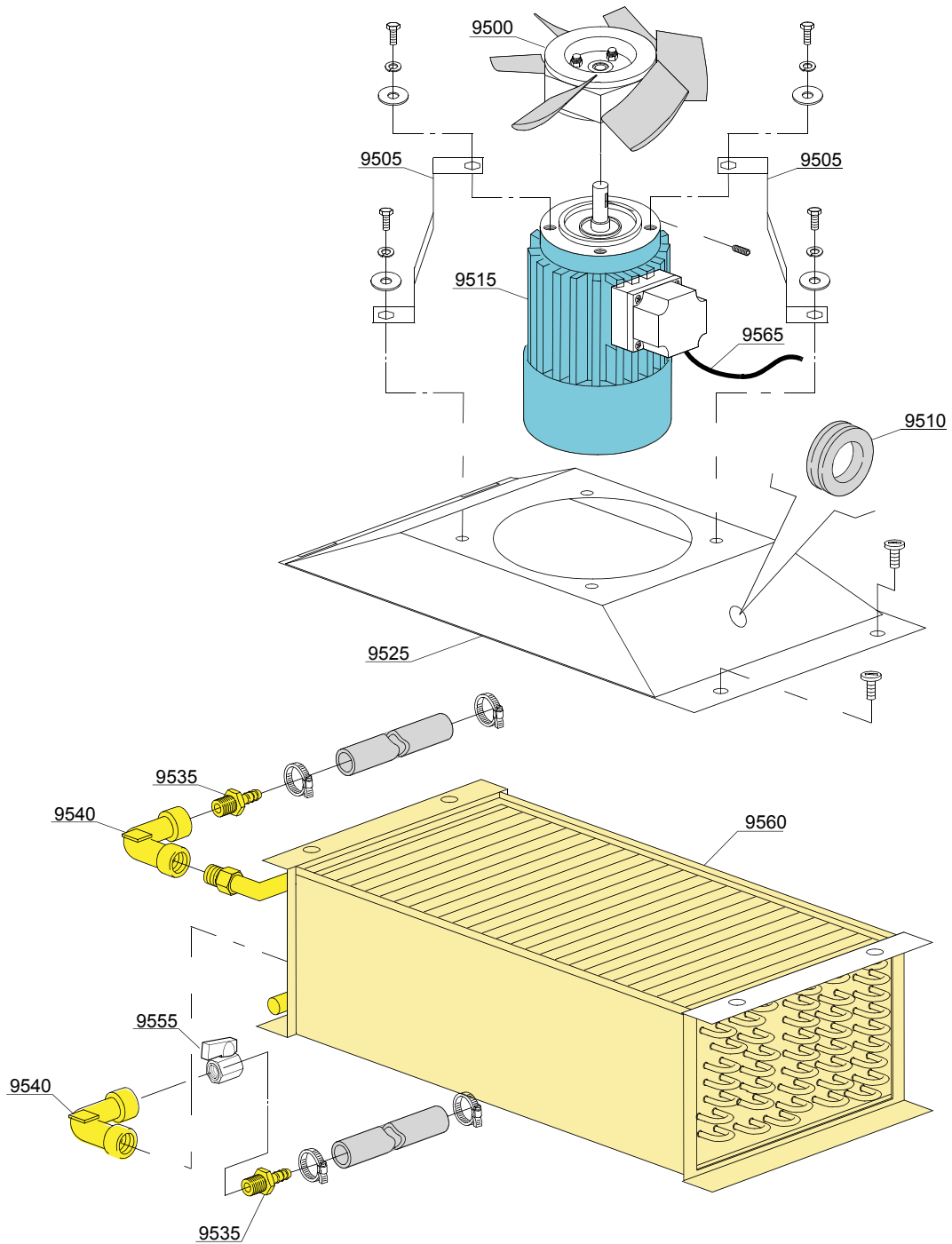

vsezip.ru

ID	P-code	SN from	SN to	Mod	Acces.	Volt	Description
Module: Steam condenser / Heat recovery LC71 / TR70 - part 2 [61,290,1700,2700]							
9500	3000124		-	e,uw			Impeller fan
9505	3009551		-	e,uw			Motor holder
9510	13329		-	e,uw			Fairlead
9515	3000123		-	e,uw			Motor - 0,12KW 2P 230/400V 50HZ
9525	3009583		-	e,uw			Steam condenser base
9535	12023		-	e,uw			Hose holder
9540	3002139		-	e,uw			Elbow
9555	3002140		-	e,uw			Tap
9560	3000155		-	e,uw			Heating recovery battery
9565	15184		-	e,uw			Cable

em=ELECTROMECHANICAL SWITCHES, e=ELECTRONICAL SWITCHES, uw=LOWER AND UPPER WASHER
91=91

hr=HEAT RECOVERY - TR98, hr=HEAT RECOVERY - TR71, sc8=STEAM CONDENSER - LC 81, sc8=STEAM CONDENSER - LC 71, d9=DRYER - LC 90, sz8=SPLASH ZONE - LC 83, ti=TANK INSULATION, ds=DOUBLE SKIN, bp=BOOSTER PUMP, sdn3=DISPENSER SYSTEM SDN-3, 98=ANGLE LOADING TABLE - LC 98

A=3/N/PE~380-400V 50-60Hz, D=3/PE~200-210V 50-60Hz, F=2/PE~220-240V 50-60Hz, G=3/N/PE~415V 50-60Hz, H=3/PE~220-230V 50-60Hz, K=3/PE~380-400V 50-60Hz, L=3/PE~415V 50-60Hz, M=3/PE~440V 60Hz, P=1/N/PE~220-230V 50-60Hz, R=2/PE~220-240V 50-60Hz, U=1/N/PE~240V 50-60Hz, V=3/PE~240V 50-60Hz, W=1/N/PE~100-110V 50-60Hz

vsezip.ru

+7(812)987-08-81

22_002ae

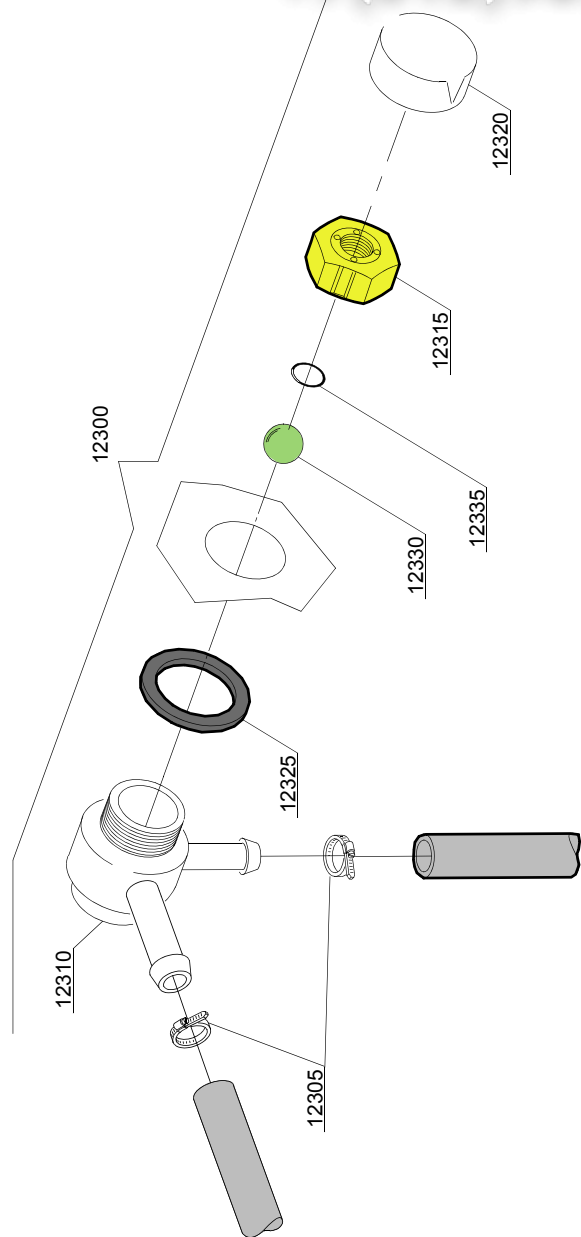

vsezip.ru

ID	P-code	SN from	SN to	Mod.	Acces.	Volt	Description
Module: DVGW valve [161,290,1700,2700]							
12300	9891710		-	e,uw			DVGW valvola assembly
12305	11807		-	e,uw			Clamp aisi430 12/22
12310	15280		-	e,uw			Valve body center
12315	15281		-	e,uw			Flat valve
12320	15282		-	e,uw			Flat valve cover
12325	15283		-	e,uw			Valve gasket
12330	15284		-	e,uw			Sphere
12335	15285		-	e,uw			O-ring 115 KTW

em=ELECTROMECHANICAL SWITCHES, e=ELECTRONICAL SWITCHES, uw=LOWER AND UPPER WASHER
91=91

hr=HEAT RECOVERY - TR98, hr=HEAT RECOVERY - TR71, sc8=STEAM CONDENSER - LC 81, sc8=STEAM CONDENSER - LC 71, d9=DRYER - LC 90, sz8=SPLASH ZONE - LC 83, ti=TANK INSULATION, ds=DOUBLE SKIN, bp=BOOSTER PUMP, sdn3=DISPENSER SYSTEM SDN-3, 98=ANGLE LOADING TABLE - LC 98

A=3/N/PE~380-400V 50-60Hz, D=3/PE~200-210V 50-60Hz, F=2/PE~220-240V 50-60Hz, G=3/N/PE~415V 50-60Hz, H=3/PE~220-230V 50-60Hz, K=3/PE~380-400V 50-60Hz, L=3/PE~415V 50-60Hz, M=3/PE~440V 60Hz, P=1/N/PE~220-230V 50-60Hz, R=2/PE~220-240V 50-60Hz, U=1/N/PE~240V 50-60Hz, V=3/PE~240V 50-60Hz, W=1/N/PE~100-110V 50-60Hz

vsezip.ru

+7(812)987-08-81

23_002_e

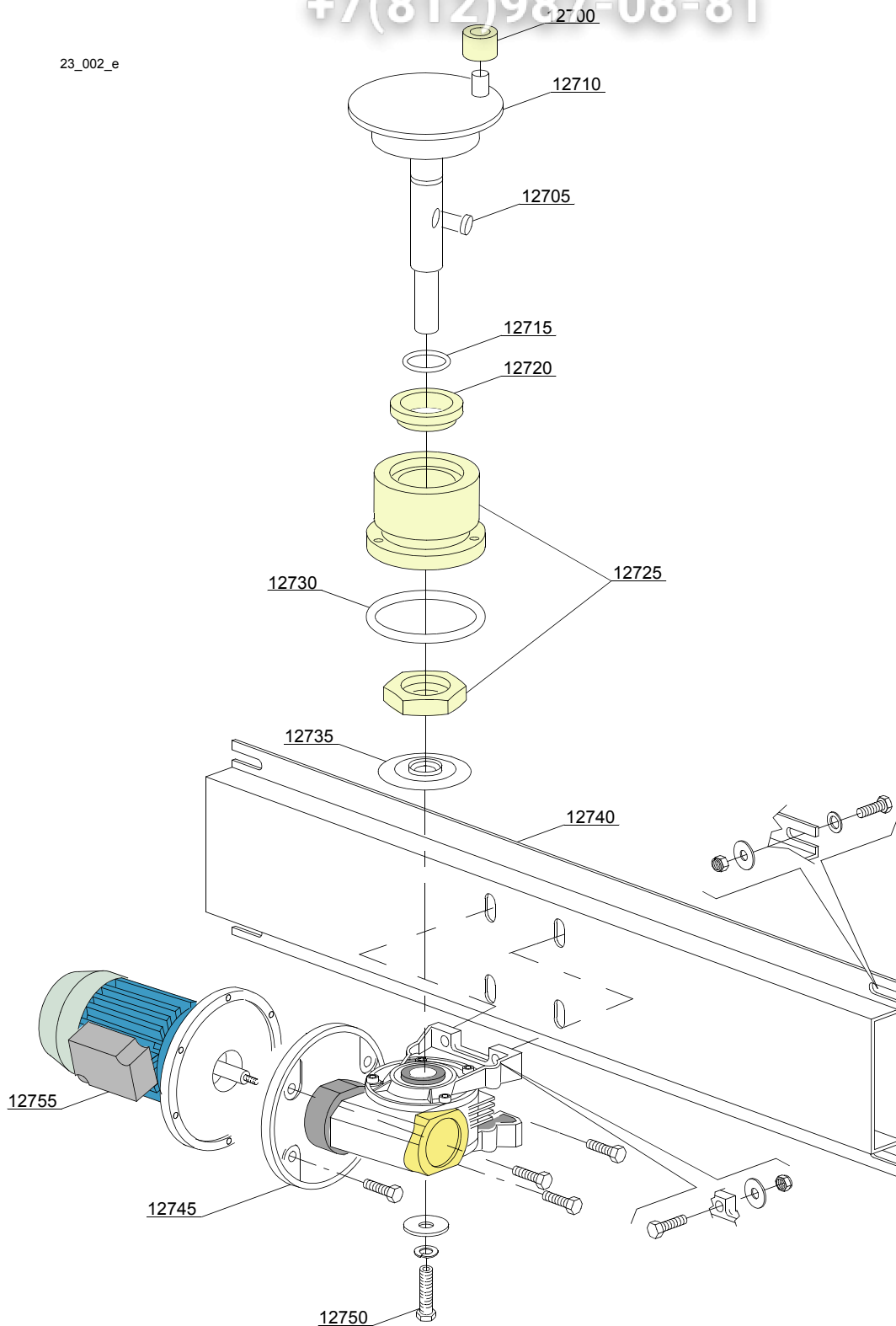

vsezip.ru

ID	P-code	SN from	SN to	Mod.	Acces.	Volt	Description
Module: Motorgear components [161,290,1700,2700]							
12700	3003012		-	e,uw			Conveyor roller
12705	2001046		-	e,uw			Key
12710	3003116		-	e,uw			Crank shaft
12715	13023		-	e,uw			O-ring 131 (4093)
12720	13024		-	e,uw			Oil splash guard DEM 40 TC 30x42x7 with spring
12725	3004131		-	e,uw			Coupling part serie
12730	13015		-	e,uw			O-ring 160 (6225)
12735	3004161		-	e,uw			Protection disk
12740	3009060		-	e,uw			Motorgear support
12745	3000210		-	e,uw			Gear right 1:80 DX
12745	3000214		-	e,uw			Gear right 1:45 (60Hz) DX
12755	3000107/A		-	e,uw			Conveyor motor - 6/8P 440V 60Hz - reduced
12755	3000107		-	e,uw			Conveyor motor - 6/8P 400V 50Hz - reduced
12755	3000108		-	e,uw			Conveyor motor - 6/8P 230V 50Hz - reduced
12755	3000110		-	e,uw			Conveyor motor - 6/8P 400/415V 50Hz

em=ELECTROMECHANICAL SWITCHES, e=ELECTRONICAL SWITCHES, uw=LOWER AND UPPER WASHER
91=91

hr=HEAT RECOVERY - TR98, hr=HEAT RECOVERY - TR71, sc8=STEAM CONDENSER - LC 81, sc8=STEAM CONDENSER - LC 71, d9=DRYER - LC 90, sz8=SPLASH ZONE - LC 83, ti=TANK INSULATION, ds=DOUBLE SKIN, bp=BOOSTER PUMP, sdn3=DISPENSER SYSTEM SDN-3, 98=ANGLE LOADING TABLE - LC 98

A=3/N/PE~380-400V 50-60Hz, D=3/PE~200-210V 50-60Hz, F=2/PE~220-240V 50-60Hz, G=3/N/PE~415V 50-60Hz, H=3/PE~220-230V 50-60Hz, K=3/PE~380-400V 50-60Hz, L=3/PE~415V 50-60Hz, M=3/PE~440V 60Hz, P=1/N/PE~220-230V 50-60Hz, R=2/PE~220-240V 50-60Hz, U=1/N/PE~240V 50-60Hz, V=3/PE~240V 50-60Hz, W=1/N/PE~100-110V 50-60Hz

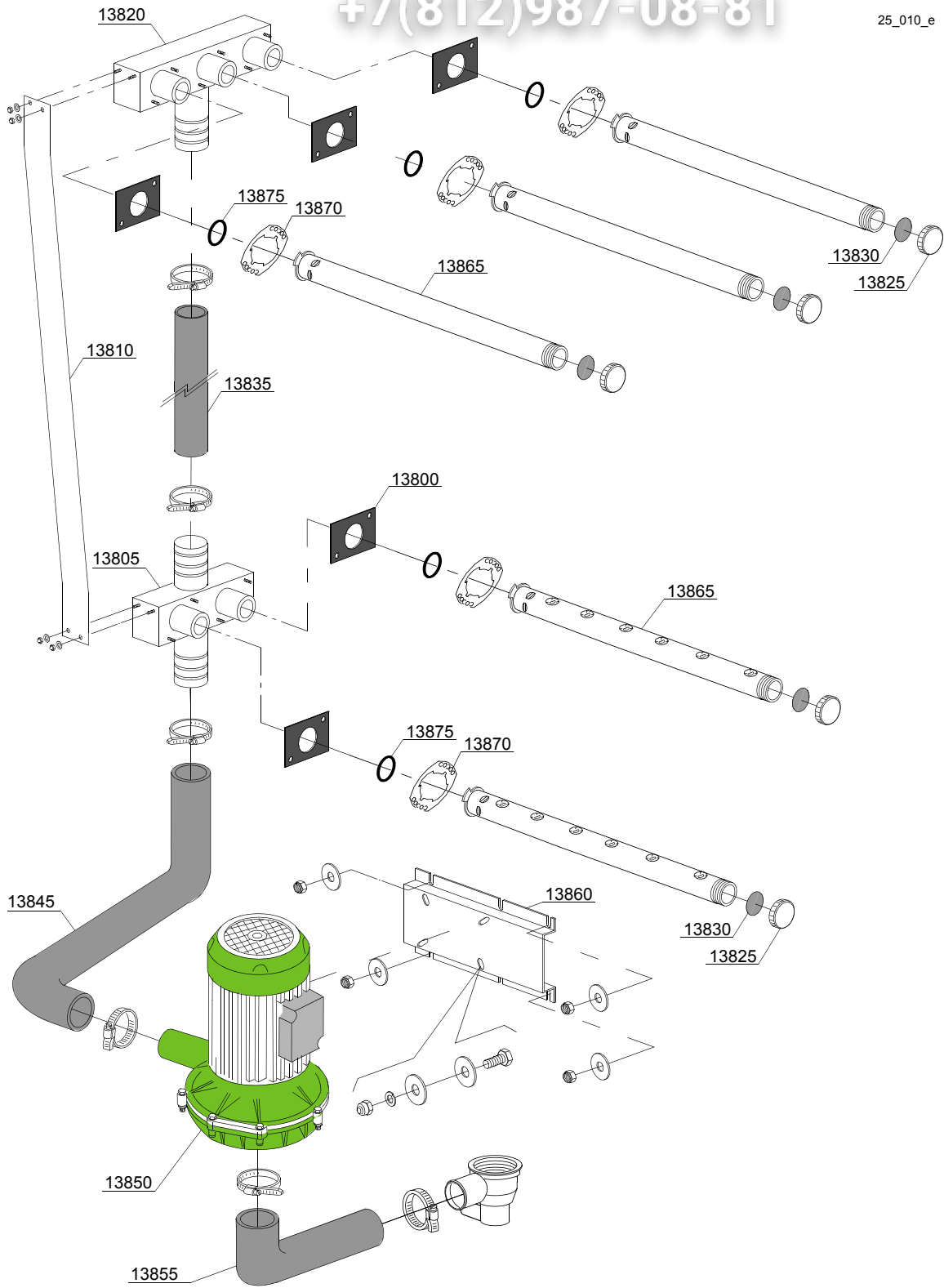

ID	P-code	SN from	SN to	Mod.	Acces.	Volt	Description
Module: Washing components 3+2 [161,290,1700,2700]							
13800	391029		-	e,uw			Gasket
13805	391028		-	e,uw			Inferior wash ramp 3+2
13810	391042		-	e,uw			Water flow adjuster
13820	391027		-	e,uw			Upper wash ramp 3+2
13825	80304		-	e,uw			Arm plug
13830	80305		-	e,uw			Gasket
13835	3060212		-	e,uw			Elbow coupling press. Ø 42
13845	391026		-	e,uw			Elbow coupling, press.
13850	88106/D		-	e,uw		A	Pump HP 2,7 220/380 60Hz
13850	88107		-	e,uw		H	Pump HP 2,7 220/380 50Hz
13855	11600100		-	e,uw			Suction elbow coupling
13860	11600623		-	e,uw			Pump support
13865	391031		-	e,uw			Wash arm
13870	3060182		-	e,uw			Arm connection flange
13875	392050		-	e,uw			OR Gasket 3x31 NBR 70SH

em=ELECTROMECHANICAL SWITCHES, e=ELECTRONICAL SWITCHES, uw=LOWER AND UPPER WASHER
91=91

hr=HEAT RECOVERY - TR98, hr=HEAT RECOVERY - TR71, sc8=STEAM CONDENSER - LC 81, sc8=STEAM CONDENSER - LC 71, d9=DRYER - LC 90, sz8=SPLASH ZONE - LC 83, ti=TANK INSULATION, ds=DOUBLE SKIN, bp=BOOSTER PUMP, sdn3=DISPENSER SYSTEM SDN-3, 98=ANGLE LOADING TABLE - LC 98

A=3/N/PE~380-400V 50-60Hz, D=3/PE~200-210V 50-60Hz, F=2/PE~220-240V 50-60Hz, G=3/N/PE~415V 50-60Hz, H=3/PE~220-230V 50-60Hz, K=3/PE~380-400V 50-60Hz, L=3/PE~415V 50-60Hz, M=3/PE~440V 60Hz, P=1/N/PE~220-230V 50-60Hz, R=2/PE~220-240V 50-60Hz, U=1/N/PE~240V 50-60Hz, V=3/PE~240V 50-60Hz, W=1/N/PE~100-110V 50-60Hz

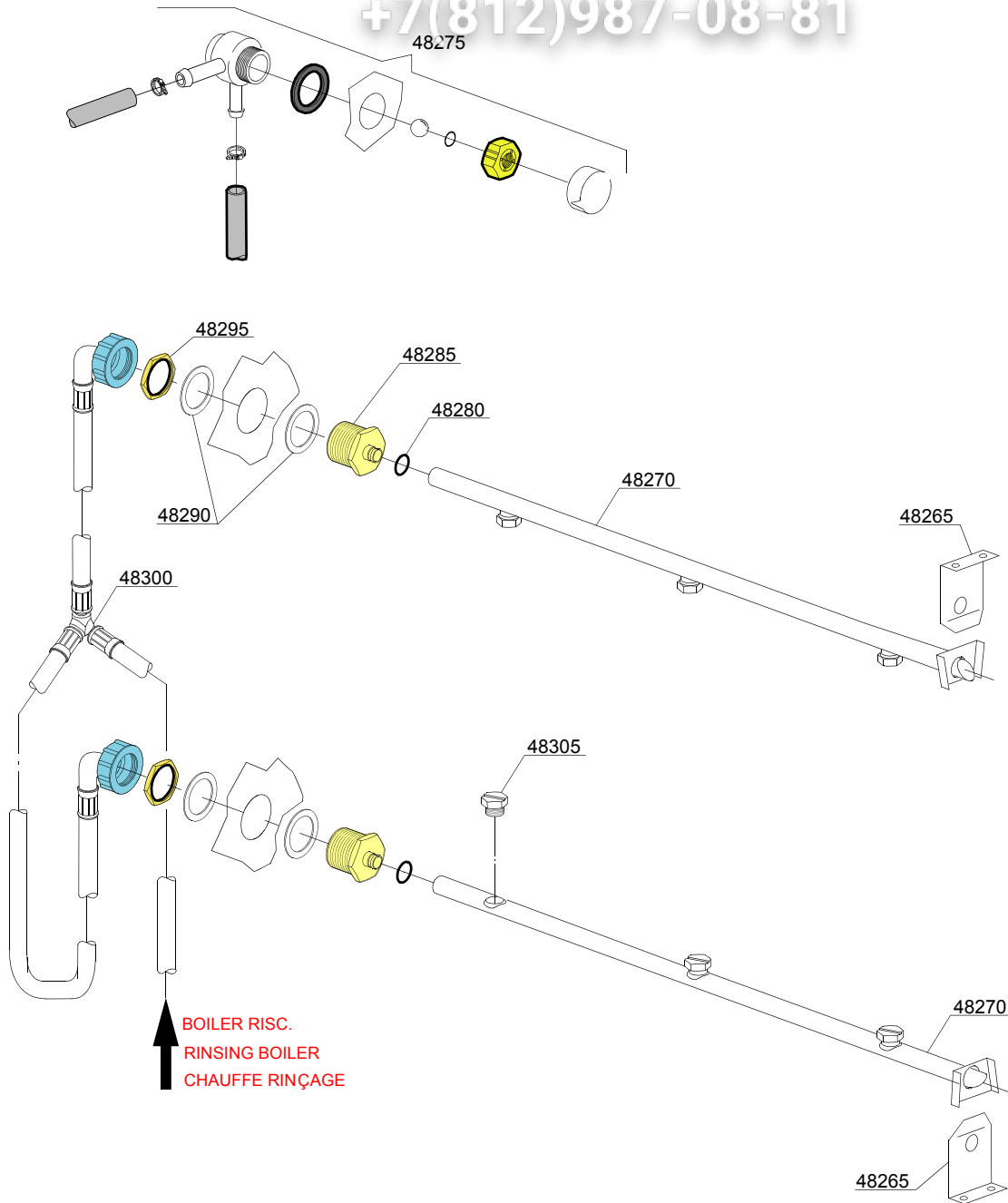

vsezip.ru

ID	P-code	SN from	SN to	Mod.	Acces.	Volt	Description
Module:Rinsing components [161,290,1700,2700]							
48265	3003905		-	e,uw			Support rinsing arm
48270	391033		-	e,uw			Rinsing arm 3 nozzle
48275	9891710		-	e,uw			DVGW valve
48280	13025		-	e,uw			O-ring Gasket 2081
48285	3003125		-	e,uw			Rinsing graft arm
48290	13326		-	e,uw			Ø 38x27x2 Gasket
48295	2200103		-	e,uw			3/4 Nut ES 32x8
48300	3003126		-	e,uw			"Y" Axis rinsing
48305	391034		-	e,uw			Inox rinsing nozzle

em=ELECTROMECHANICAL SWITCHES, e=ELECTRONICAL SWITCHES, uw=LOWER AND UPPER WASHER
91=91

hr=HEAT RECOVERY - TR98, hr=HEAT RECOVERY - TR71, sc8=STEAM CONDENSER - LC 81, sc8=STEAM CONDENSER - LC 71, d9=DRYER - LC 90, sz8=SPLASH ZONE - LC 83, ti=TANK INSULATION, ds=DOUBLE SKIN, bp=BOOSTER PUMP, sdn3=DISPENSER SYSTEM SDN-3, 98=ANGLE LOADING TABLE - LC 98

A=3/N/PE~380-400V 50-60Hz, D=3/PE~200-210V 50-60Hz, F=2/PE~220-240V 50-60Hz, G=3/N/PE~415V 50-60Hz, H=3/PE~220-230V 50-60Hz, K=3/PE~380-400V 50-60Hz, L=3/PE~415V 50-60Hz, M=3/PE~440V 60Hz, P=1/N/PE~220-230V 50-60Hz, R=2/PE~220-240V 50-60Hz, U=1/N/PE~240V 50-60Hz, V=3/PE~240V 50-60Hz, W=1/N/PE~100-110V 50-60Hz

vsezip.ru

+7(812)987-08-81

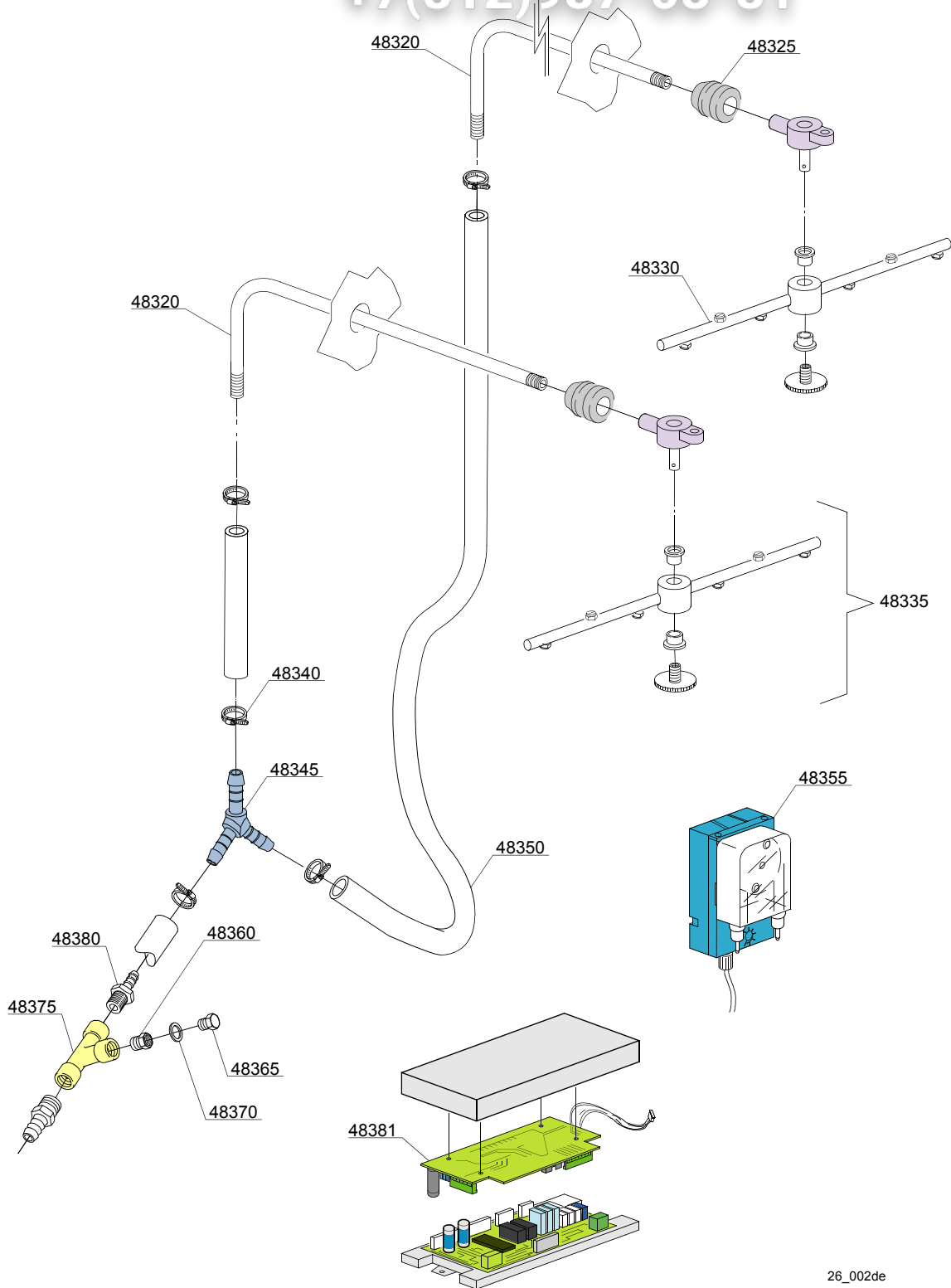

26_002de

ID	P-code	SN from	SN to	Mod.	Acces	Volt	Description
Module: System components sanitization [161,170]							
48320	391065		-	e,uw			Rinse sanitization
48325	13304		-	e,uw			Pipe pas O-ring
48330	391066		-	e,uw			Sanitization rotor
48335	75918		-	e,uw			Rotor sanitization group
48340	11800		-	e,uw			8/16 Clamp
48345	540090		-	e,uw			Ø 10 Plastic 3 ways connection
48350	14506		-	e,uw			EPDM Ø10x17 rubber pipe
48355	391067		-	e,uw			Dosing sanitization system 220/50 3L/H
48360	12032		-	e,uw			Reduction nipples 1/8F - 1/4M
48365	12002		-	e,uw			Plug 1/8M
48370	13309		-	e,uw			O-ring Ø10x14x1,5
48375	391068		-	e,uw			Sanitization connection
48380	12005		-	e,uw			Rubber holder 1/4G OT-NI
48381	391064		-	e,uw			EXP card sanitization

em=ELECTROMECHANICAL SWITCHES, e=ELECTRONICAL SWITCHES, uw=LOWER AND UPPER WASHER
91=91

hr=HEAT RECOVERY - TR98, hr=HEAT RECOVERY - TR71, sc8=STEAM CONDENSER - LC 81, sc8=STEAM CONDENSER - LC 71, d9=DRYER - LC 90, sz8=SPLASH ZONE - LC 83, ti=TANK INSULATION, ds=DOUBLE SKIN, bp=BOOSTER PUMP, sdn3=DISPENSER SYSTEM SDN-3, 98=ANGLE LOADING TABLE - LC 98

A=3/N/PE~380-400V 50-60Hz, D=3/PE~200-210V 50-60Hz, F=2/PE~220-240V 50-60Hz, G=3/N/PE~415V 50-60Hz, H=3/PE~220-230V 50-60Hz, K=3/PE~380-400V 50-60Hz, L=3/PE~415V 50-60Hz, M=3/PE~440V 60Hz, P=1/N/PE~220-230V 50-60Hz, R=2/PE~220-240V 50-60Hz, U=1/N/PE~240V 50-60Hz, V=3/PE~240V 50-60Hz, W=1/N/PE~100-110V 50-60Hz

vsezip.ru

+7(812)987-08-81

27_001ae

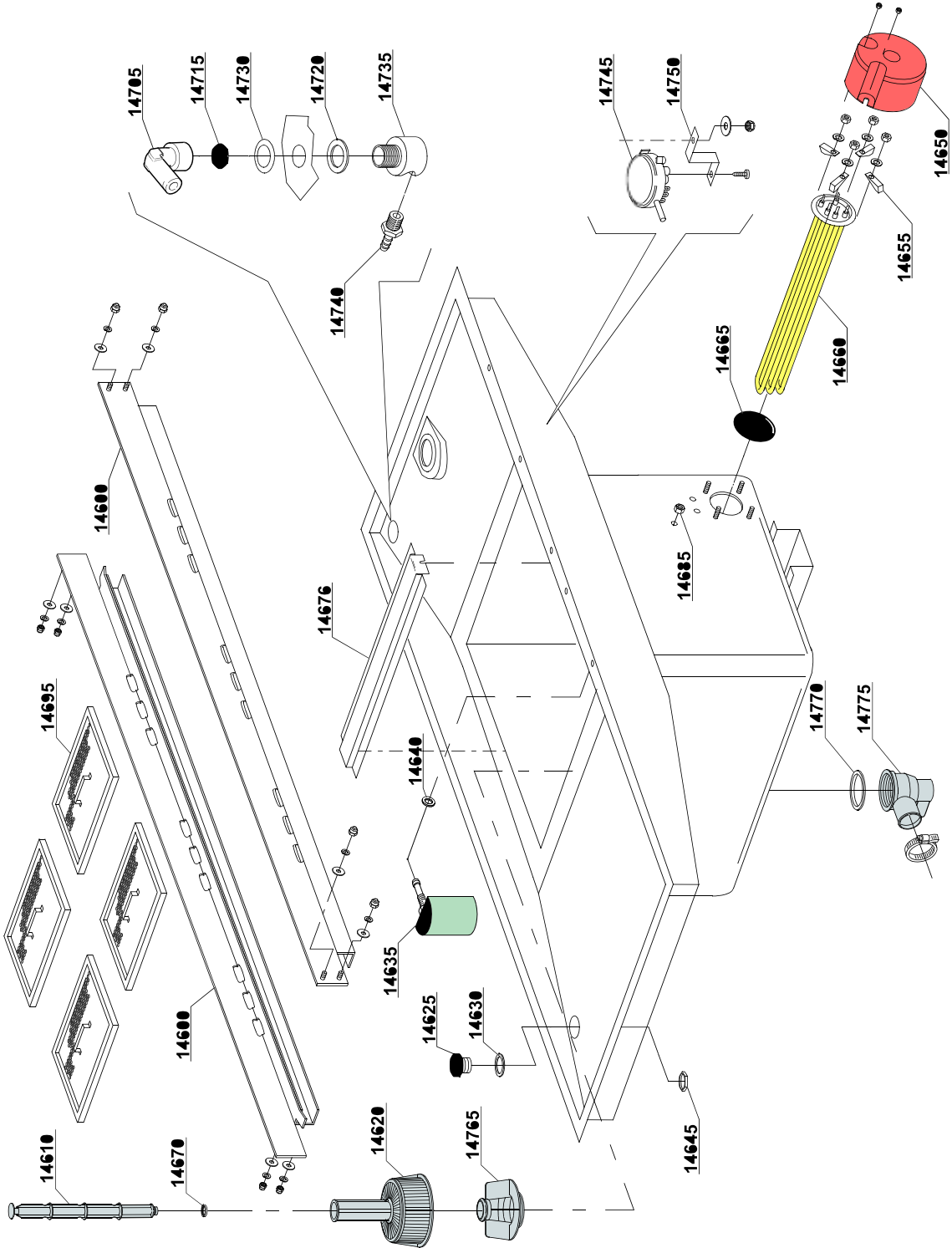

ID	P-code	SN from	SN to	Mod.	Acces.	Volt	Description
Module: Internal components [161,1700]							
14600	391043		-	e,uw			Basket-slide bar
14610	11600102		-	e,uw			Overflow pipe assembly
14620	500599		-	e,uw			Pump suction-filter
14625	3004087		-	e,uw			Plug for tank
14630	13326		-	e,uw			Gasket 38x27x2
14635	135911		-	e,uw			Air trap
14640	13301		-	e,uw			Gasket ROLMART 14x8x1.5
14645	2200103		-	e,uw			Nut
14650	75311		-	e,uw			Heating element cover
14655	16045		-	e,uw			Heating element support Ø6.3
14660	30001011		-	e,uw			Heating element 9kW 230/240 V 3
14660	30001011/A		-	e,uw			Heating element 12kW 230/240 V 3
14660	30001011/B		-	e,uw			Heating element 14kW 230/240 V 3
14660	30001011/C		-	e,uw			Heating element 9kW 440V
14660	30001011/D		-	e,uw			Heating element 12kW 440V
14665	13015		-	e,uw			O-ring 160 (6225)
14670	13021		-	e,uw			DEM 40 O-ring
14676	93509		-	e,uw			Support filter
14685	11702		-	e,uw			Nut
14695	11600907		-	e,uw			Strainer plate
14705	12018		-	e,uw			Pipe elbow F/F 3/8"
14715	10200101		-	e,uw			Nut
14720	10200171		-	e,uw			Gasket FASIT 25x17x2
14730	3009387		-	e,uw			Washer
14735	80231		-	e,uw			Fitting
14740	12005		-	e,uw			Hose holder
14745	88110		-	e,uw			Pressure switch (260-30)
14750	3009363		-	e,uw			Pressure switch support

em=ELECTROMECHANICAL SWITCHES, e=ELECTRONICAL SWITCHES, uw=LOWER AND UPPER WASHER
91=91

hr=HEAT RECOVERY - TR98, hr=HEAT RECOVERY - TR71, sc8=STEAM CONDENSER - LC 81, sc8=STEAM CONDENSER - LC 71, d9=DRYER - LC 90, sz8=SPLASH ZONE - LC 83, ti=TANK INSULATION, ds=DOUBLE SKIN, bp=BOOSTER PUMP, sdn3=DISPENSER SYSTEM SDN-3, 98=ANGLE LOADING TABLE - LC 98

A=3/N/PE~380-400V 50-60Hz, D=3/PE~200-210V 50-60Hz, F=2/PE~220-240V 50-60Hz, G=3/N/PE~415V 50-60Hz, H=3/PE~220-230V 50-60Hz, K=3/PE~380-400V 50-60Hz, L=3/PE~415V 50-60Hz, M=3/PE~440V 60Hz, P=1/N/PE~220-230V 50-60Hz, R=2/PE~220-240V 50-60Hz, U=1/N/PE~240V 50-60Hz, V=3/PE~240V 50-60Hz, W=1/N/PE~100-110V 50-60Hz

vsezip.ru

+7(812)987-08-81

27_001ac

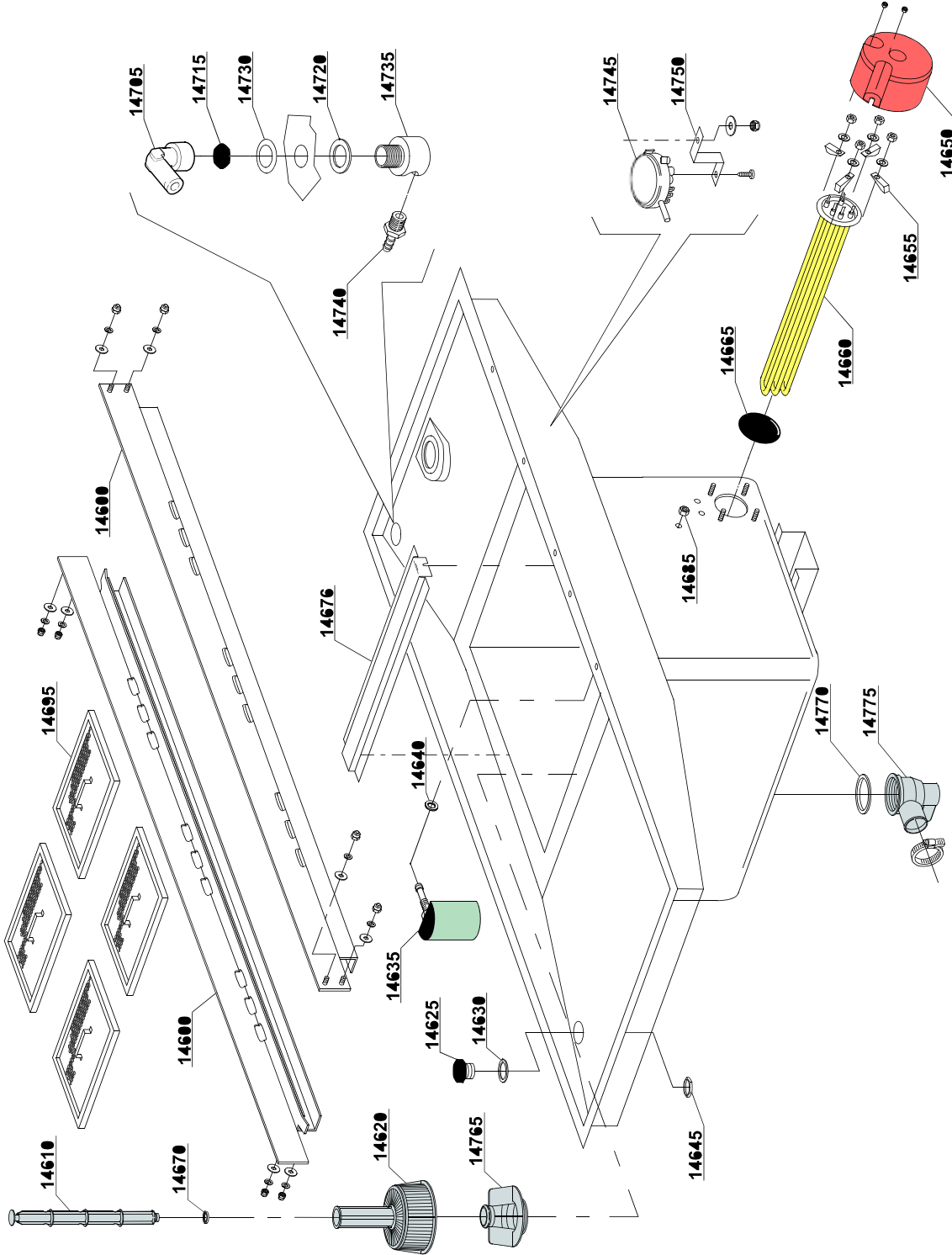

vsezip.ru

ID	P-code	SN from	SN to	Mod.	Acces.	Volt	Description
Module: Internal components [161,1700]							
14765	500615		-	e,uw			Ferrule with filter
14770	80208		-	e,uw			O-ring 95x75x3
14775	500603		-	e,uw			Lateral outlet connection

em=ELECTROMECHANICAL SWITCHES, e=ELECTRONICAL SWITCHES, uw=LOWER AND UPPER WASHER
91=91

hr=HEAT RECOVERY - TR98, hr=HEAT RECOVERY - TR71, sc8=STEAM CONDENSER - LC 81, sc8=STEAM CONDENSER - LC 71, d9=DRYER - LC 90, sz8=SPLASH ZONE - LC 83, ti=TANK INSULATION, ds=DOUBLE SKIN, bp=BOOSTER PUMP, sdn3=DISPENSER SYSTEM SDN-3, 98=ANGLE LOADING TABLE - LC 98

A=3/N/PE~380-400V 50-60Hz, D=3/PE~200-210V 50-60Hz, F=2/PE~220-240V 50-60Hz, G=3/N/PE~415V 50-60Hz, H=3/PE~220-230V 50-60Hz, K=3/PE~380-400V 50-60Hz, L=3/PE~415V 50-60Hz, M=3/PE~440V 60Hz, P=1/N/PE~220-230V 50-60Hz, R=2/PE~220-240V 50-60Hz, U=1/N/PE~240V 50-60Hz, V=3/PE~240V 50-60Hz, W=1/N/PE~100-110V 50-60Hz

vsezip.ru

+7(812)987-08-81

28_201ae

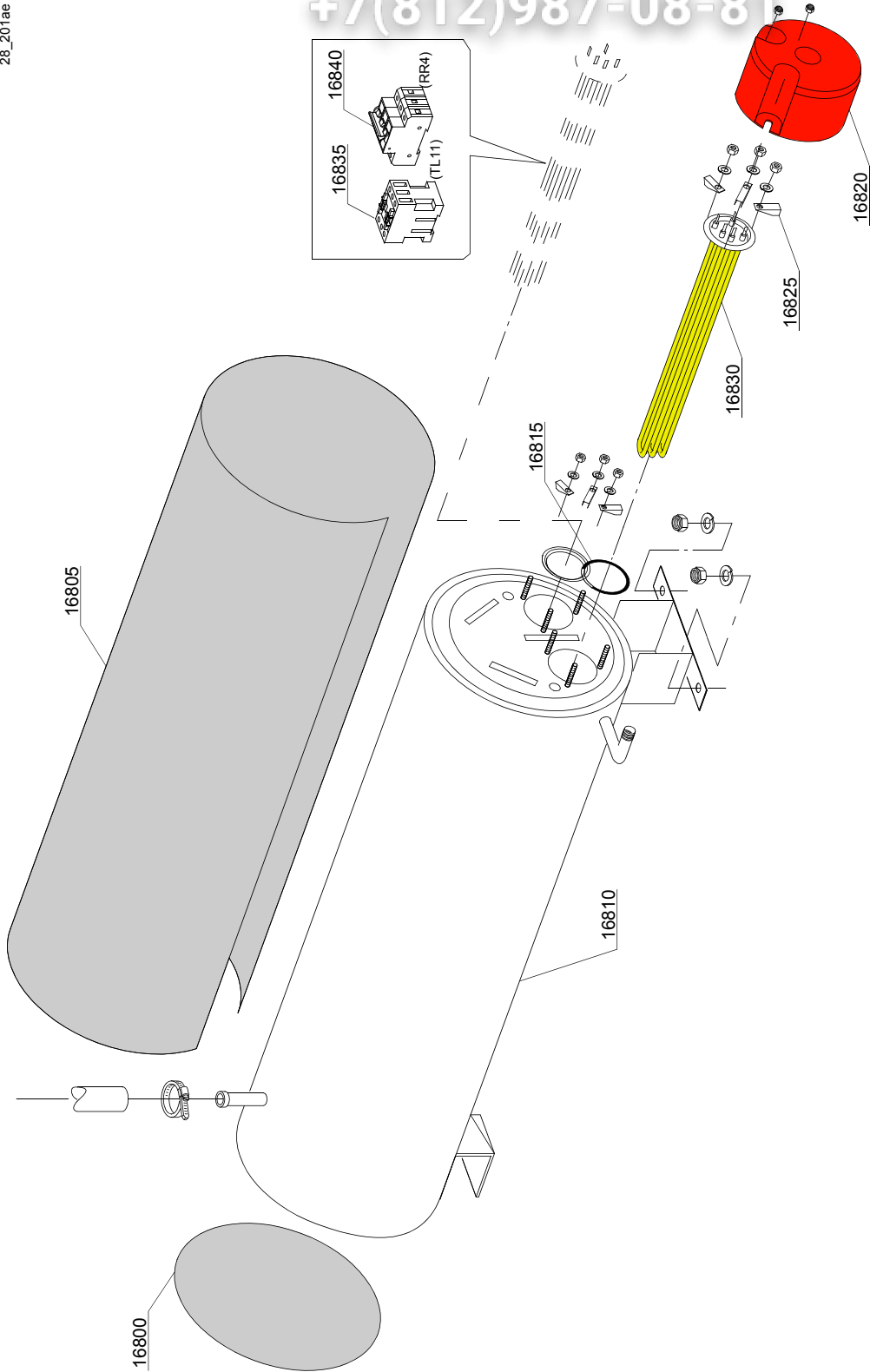

ID	P-code	SN from	SN to	Mod	Acces.	Volt	Description
Module:Boiler components [161,290,1700,2700]							
16800	392006		-	e,uw			Bottom boiler insulating
16805	392005		-	e,uw			Boiler insulating
16810	392004		-	e,uw			Boiler
16815	13015		-	e,uw			O-ring 160 (6225)
16820	75311		-	e,uw			Heating element cover
16825	16045		-	e,uw			Heating element support Ø6.3
16830	30001011		-	e,uw			Heating element 9kW 230/240 V 3
16830	30001011/A		-	e,uw			Heating element 12kW 230/240 V 3
16830	30001011/B		-	e,uw			Heating element 14kW 230/240 V 3
16830	30001011/C		-	e,uw			Heating element 9kW 440V
16830	30001011/D		-	e,uw			Heating element 12kW 440V
16835	2000380		-	e,uw			Contactora BF12 (heating element < 9 kW)
16835	2000385		-	e,uw			Contactora BF20 (heating element > 9 kW)
16840	2000403		-	e,uw			Automatic fuse C20 (heating element < 9 kW)
16840	2000404		-	e,uw			Automatic fuse C25 (heating element > 9 kW)

em=ELECTROMECHANICAL SWITCHES, e=ELECTRONICAL SWITCHES, uw=LOWER AND UPPER WASHER
91=91

hr=HEAT RECOVERY - TR98, hr=HEAT RECOVERY - TR71, sc8=STEAM CONDENSER - LC 81, sc8=STEAM CONDENSER - LC 71, d9=DRYER - LC 90, sz8=SPLASH ZONE - LC 83, ti=TANK INSULATION, ds=DOUBLE SKIN, bp=BOOSTER PUMP, sdn3=DISPENSER SYSTEM SDN-3, 98=ANGLE LOADING TABLE - LC 98

A=3/N/PE~380-400V 50-60Hz, D=3/PE~200-210V 50-60Hz, F=2/PE~220-240V 50-60Hz, G=3/N/PE~415V 50-60Hz, H=3/PE~220-230V 50-60Hz, K=3/PE~380-400V 50-60Hz, L=3/PE~415V 50-60Hz, M=3/PE~440V 60Hz, P=1/N/PE~220-230V 50-60Hz, R=2/PE~220-240V 50-60Hz, U=1/N/PE~240V 50-60Hz, V=3/PE~240V 50-60Hz, W=1/N/PE~100-110V 50-60Hz

vsezip.ru

+7(812)987-08-81

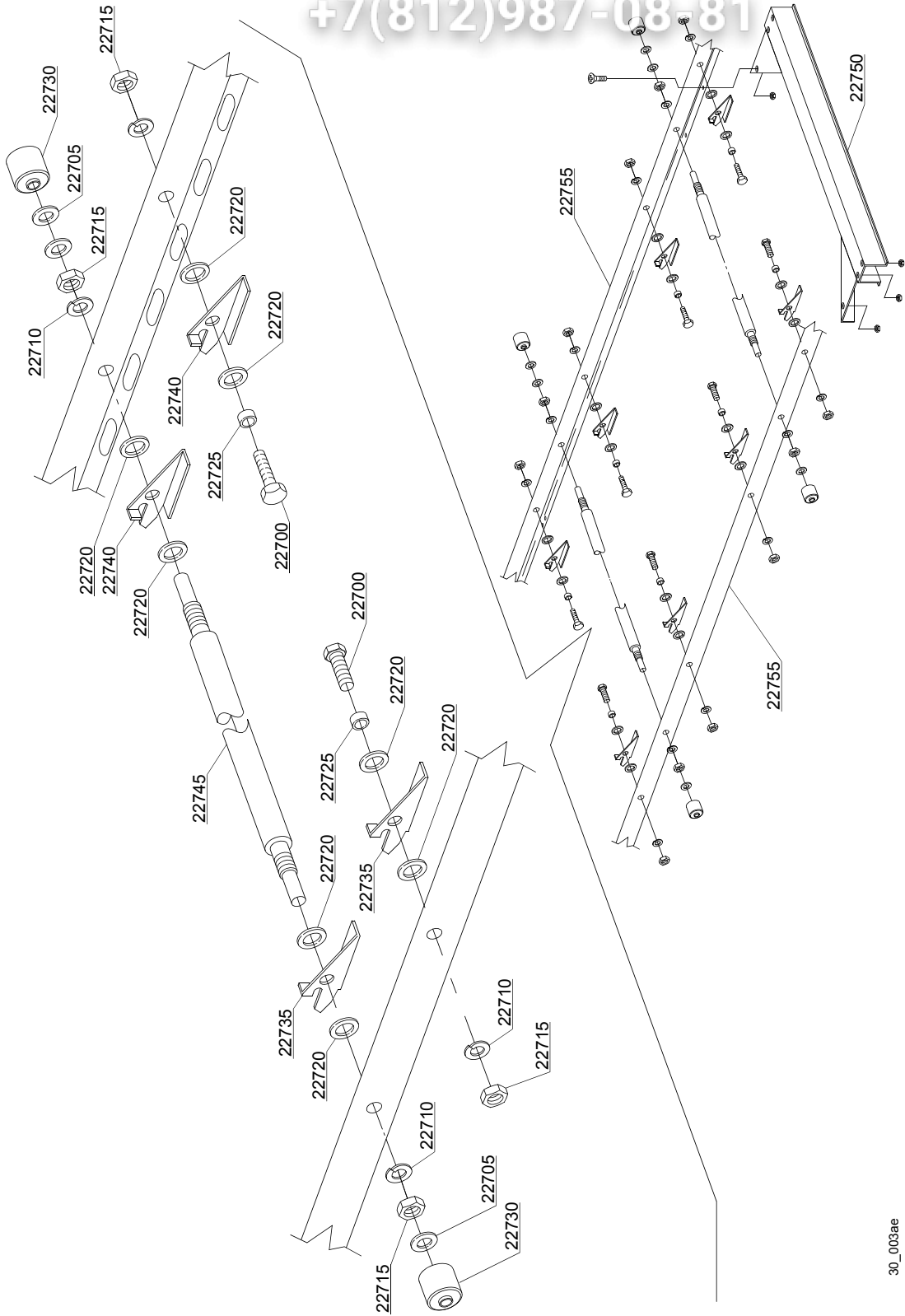

30_003ae

vsezip.ru

ID	P-code	SN from	SN to	Mod	Acces	Volt	Description
Module: Conveyor parts [161,290,1700,2700]							
22700	11109		-	e,uw			Screw
22705	11185		-	e,uw			Washer
22710	11609		-	e,uw			Split washer
22715	11719		-	e,uw			Nut
22720	3003024		-	e,uw			Washer
22725	3003025		-	e,uw			Bush
22730	3003026		-	e,uw			Bush
22735	3003100		-	e,uw			Clip right
22740	3003101		-	e,uw			Clip left
22745	3003010		-	e,uw			Axis
22750	391014		-	e,uw			Guide
22755	391048		-	e,uw			Mobile chassis

em=ELECTROMECHANICAL SWITCHES, e=ELECTRONICAL SWITCHES, uw=LOWER AND UPPER WASHER
91=91

hr=HEAT RECOVERY - TR98, hr=HEAT RECOVERY - TR71, sc8=STEAM CONDENSER - LC 81, sc8=STEAM CONDENSER - LC 71, d9=DRYER - LC 90, sz8=SPLASH ZONE - LC 83, ti=TANK INSULATION, ds=DOUBLE SKIN, bp=BOOSTER PUMP, sdn3=DISPENSER SYSTEM SDN-3, 98=ANGLE LOADING TABLE - LC 98

A=3/N/PE~380-400V 50-60Hz, D=3/PE~200-210V 50-60Hz, F=2/PE~220-240V 50-60Hz, G=3/N/PE~415V 50-60Hz, H=3/PE~220-230V 50-60Hz, K=3/PE~380-400V 50-60Hz, L=3/PE~415V 50-60Hz, M=3/PE~440V 60Hz, P=1/N/PE~220-230V 50-60Hz, R=2/PE~220-240V 50-60Hz, U=1/N/PE~240V 50-60Hz, V=3/PE~240V 50-60Hz, W=1/N/PE~100-110V 50-60Hz

vsezip.ru

+7(812)987-08-81

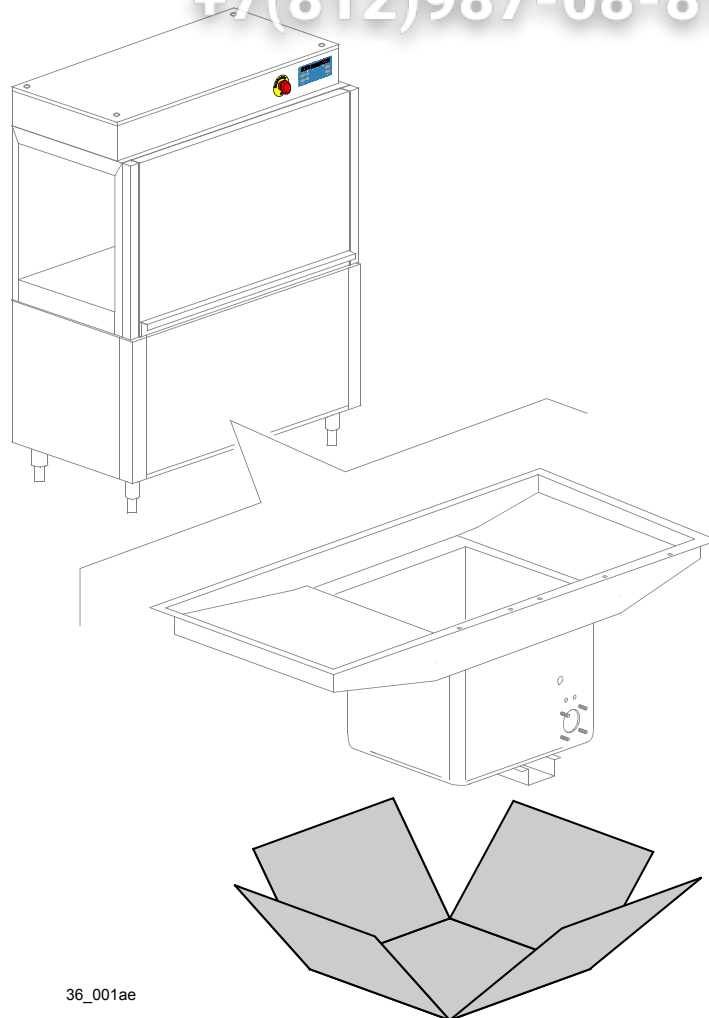

36_001ae

vsezip.ru

ID	P-code	SN from	SN to	Mod.	Acces.	Volt	Description
Module: Tank insulation [161,1700]							
999	999910214		-	e,uw	ti		Tank insulation
							N.B.: kit suppliable only together with the machine, not after

em=ELECTROMECHANICAL SWITCHES, e=ELECTRONICAL SWITCHES, uw=LOWER AND UPPER WASHER
91=91

hr=HEAT RECOVERY - TR98, hr=HEAT RECOVERY - TR71, sc8=STEAM CONDENSER - LC 81, sc8=STEAM CONDENSER - LC 71, d9=DRYER - LC 90, sz8=SPLASH ZONE - LC 83, ti=TANK INSULATION, ds=DOUBLE SKIN, bp=BOOSTER PUMP, sdn3=DISPENSER SYSTEM SDN-3, 98=ANGLE LOADING TABLE - LC 98

A=3/N/PE~380-400V 50-60Hz, D=3/PE~200-210V 50-60Hz, F=2/PE~220-240V 50-60Hz, G=3/N/PE~415V 50-60Hz, H=3/PE~220-230V 50-60Hz, K=3/PE~380-400V 50-60Hz, L=3/PE~415V 50-60Hz, M=3/PE~440V 60Hz, P=1/N/PE~220-230V 50-60Hz, R=2/PE~220-240V 50-60Hz, U=1/N/PE~240V 50-60Hz, V=3/PE~240V 50-60Hz, W=1/N/PE~100-110V 50-60Hz

vsezip.ru

+7(812)987-08-81

37_002ae

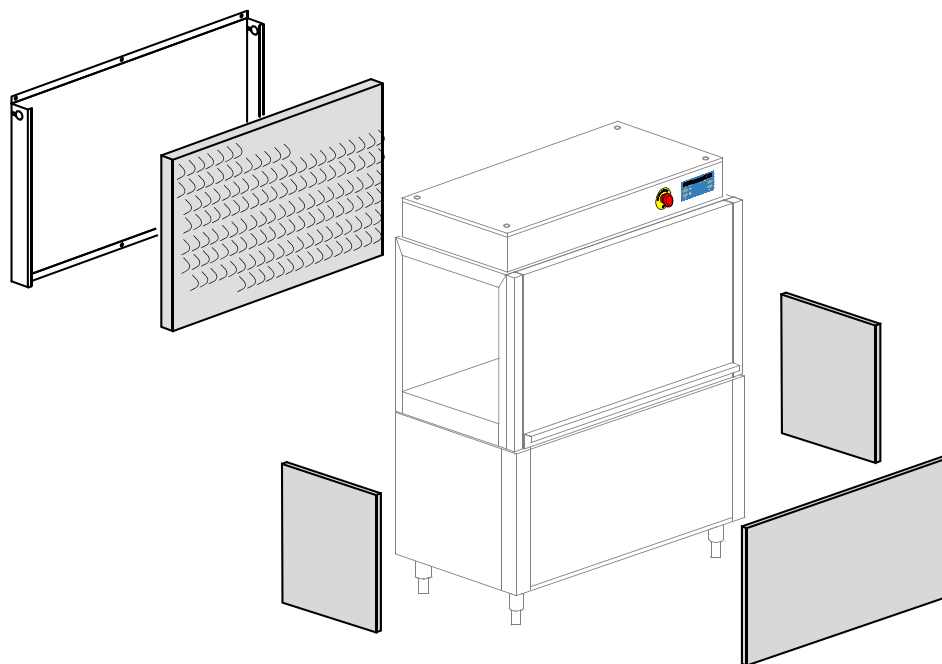

vsezip.ru

ID	P-code	SN from	SN to	Mod.	Acces.	Volt	Description
Module: Double skin [161,1700]							
999	999910074		-	e,uw	ds		Double skin assembly N.B.: kit suppliable only together with the machine, not after

em=ELECTROMECHANICAL SWITCHES, e=ELECTRONICAL SWITCHES, uw=LOWER AND UPPER WASHER
91=91

hr=HEAT RECOVERY - TR98, hr=HEAT RECOVERY - TR71, sc8=STEAM CONDENSER - LC 81, sc8=STEAM CONDENSER - LC 71, d9=DRYER - LC 90, sz8=SPLASH ZONE - LC 83, ti=TANK INSULATION, ds=DOUBLE SKIN, bp=BOOSTER PUMP, sdn3=DISPENSER SYSTEM SDN-3, 98=ANGLE LOADING TABLE - LC 98

A=3/N/PE~380-400V 50-60Hz, D=3/PE~200-210V 50-60Hz, F=2/PE~220-240V 50-60Hz, G=3/N/PE~415V 50-60Hz, H=3/PE~220-230V 50-60Hz, K=3/PE~380-400V 50-60Hz, L=3/PE~415V 50-60Hz, M=3/PE~440V 60Hz, P=1/N/PE~220-230V 50-60Hz, R=2/PE~220-240V 50-60Hz, U=1/N/PE~240V 50-60Hz, V=3/PE~240V 50-60Hz, W=1/N/PE~100-110V 50-60Hz

vsezip.ru

+7(812)987-08-81

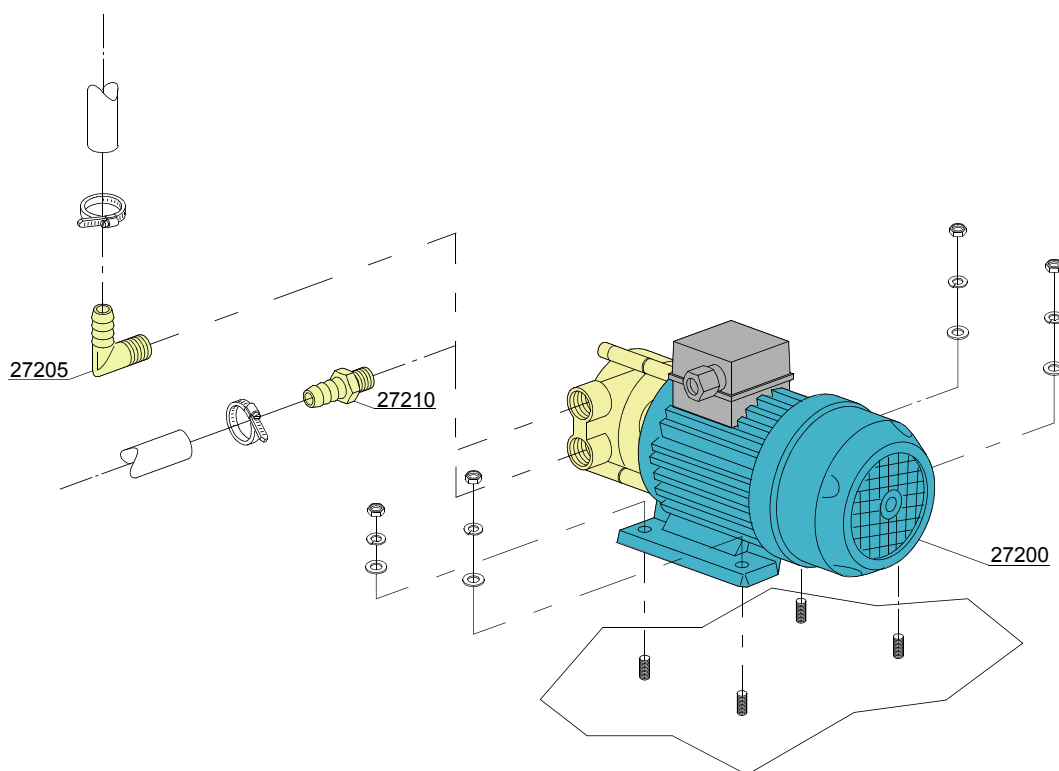
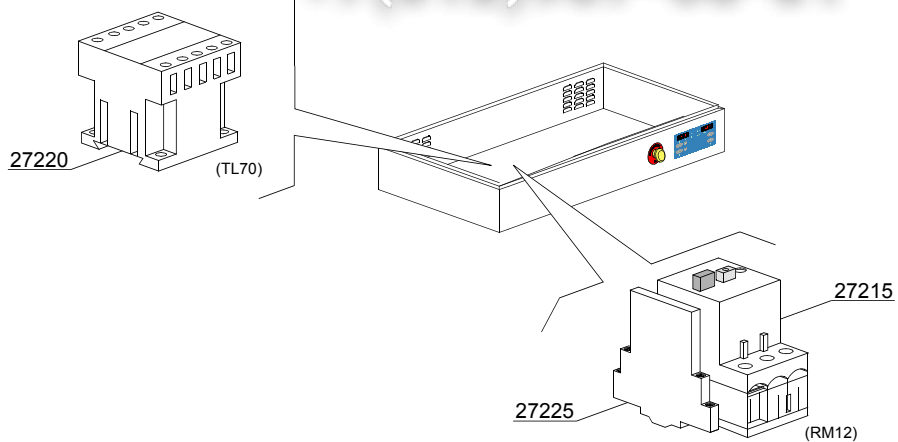

38_001_e

vsezip.ru

ID	P-code	SN from	SN to	Mod.	Acces.	Volt	Description
Module:Booster pump [161,290,1700,2700]							
27200	15100/Q		-		bp		Booster pump
27205	12030		-		bp		Elbow pipe fitting
27210	10221311		-		bp		Pipe fitting
27215	2000394		-		bp		Motorprotector 2,5-4A
27220	2000370		-		bp		Contactora MC9
27225	3006080		-		bp		Auxiliary contact LMS25

em=ELECTROMECHANICAL SWITCHES, e=ELECTRONICAL SWITCHES, uw=LOWER AND UPPER WASHER
91=91

hr=HEAT RECOVERY - TR98, hr=HEAT RECOVERY - TR71, sc8=STEAM CONDENSER - LC 81, sc8=STEAM CONDENSER - LC 71, d9=DRYER - LC 90, sz8=SPLASH ZONE - LC 83, ti=TANK INSULATION, ds=DOUBLE SKIN, bp=BOOSTER PUMP, sdn3=DISPENSER SYSTEM SDN-3, 98=ANGLE LOADING TABLE - LC 98

A=3/N/PE~380-400V 50-60Hz, D=3/PE~200-210V 50-60Hz, F=2/PE~220-240V 50-60Hz, G=3/N/PE~415V 50-60Hz, H=3/PE~220-230V 50-60Hz, K=3/PE~380-400V 50-60Hz, L=3/PE~415V 50-60Hz, M=3/PE~440V 60Hz, P=1/N/PE~220-230V 50-60Hz, R=2/PE~220-240V 50-60Hz, U=1/N/PE~240V 50-60Hz, V=3/PE~240V 50-60Hz, W=1/N/PE~100-110V 50-60Hz

vsezip.ru

+7(812)987-08-81

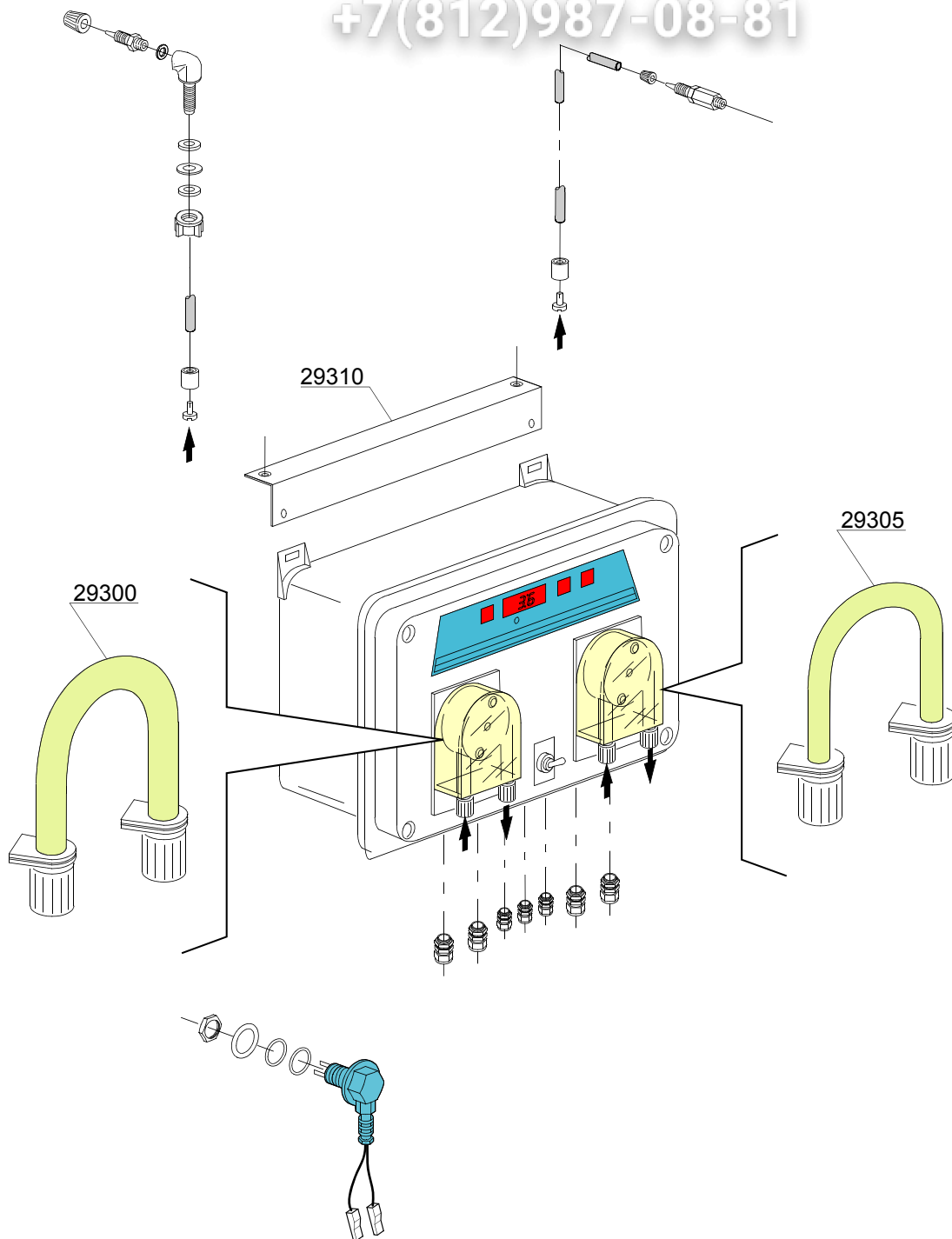

39_001_e

ID	P-code	SN from	SN to	Mod.	Acces.	Volt	Description
Module: Dispensers SDN-3 [161,290,1700,2700]							
	15181/A		-		sdn3		Dispensers assembly SDN-3
29300	15185		-		sdn3		Pipe fitting for detergent dispenser
29305	15186		-		sdn3		Pipe fitting for rinse dispenser
29310	3009669		-		sdn3		Dispensers assembly SDN-3 support

em=ELECTROMECHANICAL SWITCHES, e=ELECTRONICAL SWITCHES, uw=LOWER AND UPPER WASHER
91=91

hr=HEAT RECOVERY - TR98, hr=HEAT RECOVERY - TR71, sc8=STEAM CONDENSER - LC 81, sc8=STEAM CONDENSER - LC 71, d9=DRYER - LC 90, sz8=SPLASH ZONE - LC 83, ti=TANK INSULATION, ds=DOUBLE SKIN, bp=BOOSTER PUMP, sdn3=DISPENSER SYSTEM SDN-3, 98=ANGLE LOADING TABLE - LC 98

A=3/N/PE~380-400V 50-60Hz, D=3/PE~200-210V 50-60Hz, F=2/PE~220-240V 50-60Hz, G=3/N/PE~415V 50-60Hz, H=3/PE~220-230V 50-60Hz, K=3/PE~380-400V 50-60Hz, L=3/PE~415V 50-60Hz, M=3/PE~440V 60Hz, P=1/N/PE~220-230V 50-60Hz, R=2/PE~220-240V 50-60Hz, U=1/N/PE~240V 50-60Hz, V=3/PE~240V 50-60Hz, W=1/N/PE~100-110V 50-60Hz

vsezip.ru

+7(812)987-08-81

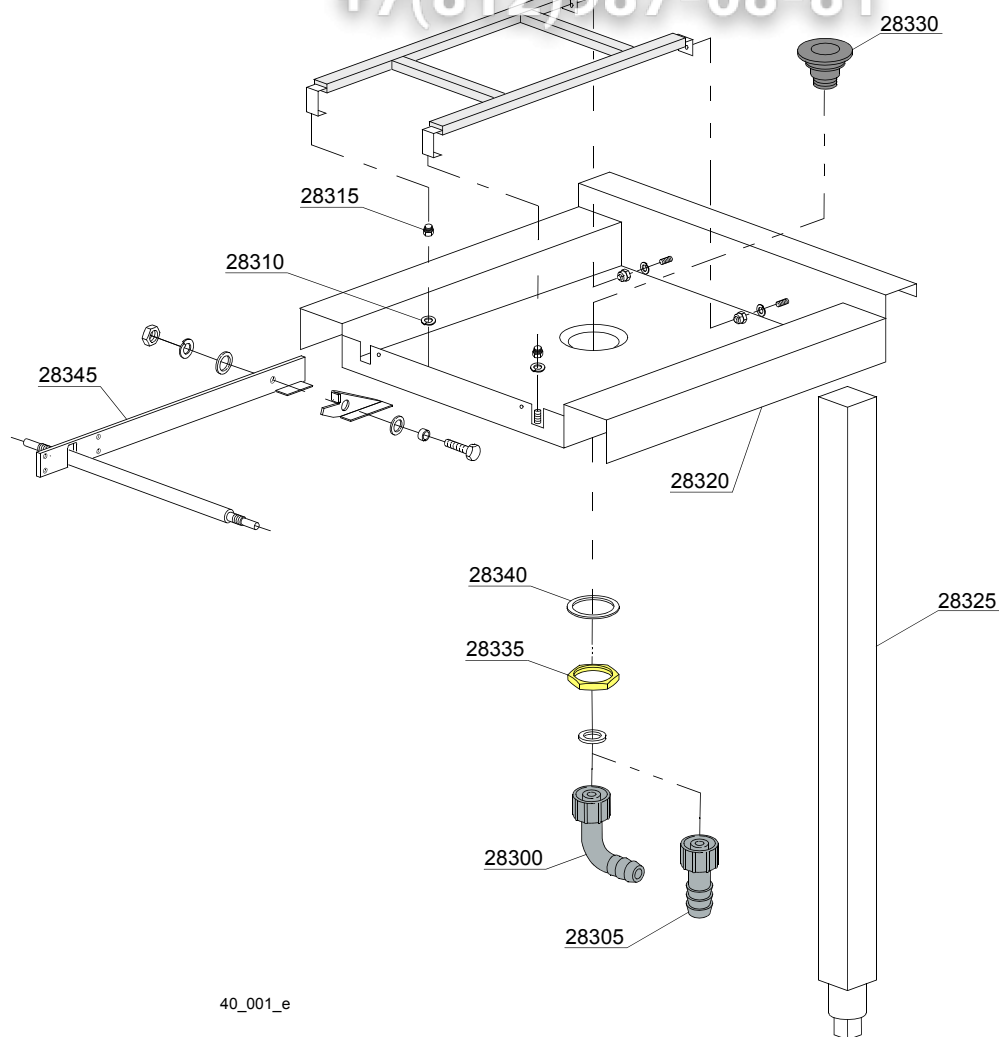

40_001_e

ID	P-code	SN from	SN to	Mod.	Acces	Volt	Description
Module: Angle loading table 90° - LC 98 [161,290,1700,270]							
28300	15613		-		98		1" 1/4x30 nylon elbow
28305	15613/A		-		98		Fitting exauster
28310	3003024		-		98		Washer
28315	3003025		-		98		Bush
28320	3009250		-		98		Platform
28325	3009608		-		98		Leg assembly
28330	10200113		-		98		Floor drain
28335	10200114		-		98		Floor drain nut
28340	10200173		-		98		Gasket 75x58x2
28345	3003071		-		98		Clip support arm (LC98 table)

em=ELECTROMECHANICAL SWITCHES, e=ELECTRONICAL SWITCHES, uw=LOWER AND UPPER WASHER
91=91

hr=HEAT RECOVERY - TR98, hr=HEAT RECOVERY - TR71, sc8=STEAM CONDENSER - LC 81, sc8=STEAM CONDENSER - LC 71, d9=DRYER - LC 90, sz8=SPLASH ZONE - LC 83, ti=TANK INSULATION, ds=DOUBLE SKIN, bp=BOOSTER PUMP, sdn3=DISPENSER SYSTEM SDN-3, 98=ANGLE LOADING TABLE - LC 98

A=3/N/PE~380-400V 50-60Hz, D=3/PE~200-210V 50-60Hz, F=2/PE~220-240V 50-60Hz, G=3/N/PE~415V 50-60Hz, H=3/PE~220-230V 50-60Hz, K=3/PE~380-400V 50-60Hz, L=3/PE~415V 50-60Hz, M=3/PE~440V 60Hz, P=1/N/PE~220-230V 50-60Hz, R=2/PE~220-240V 50-60Hz, U=1/N/PE~240V 50-60Hz, V=3/PE~240V 50-60Hz, W=1/N/PE~100-110V 50-60Hz

vsezip.ru

+7(812)987-08-81

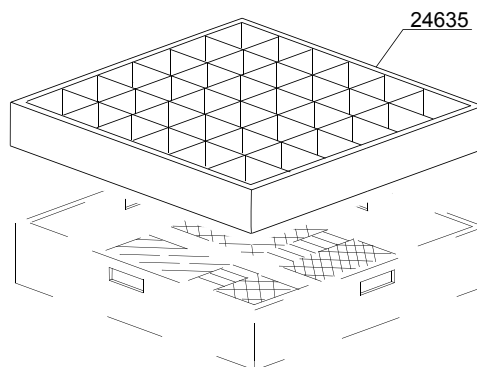
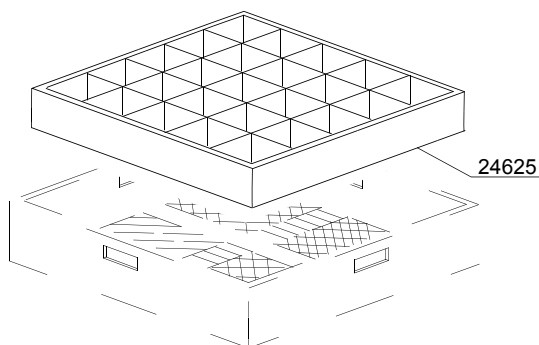
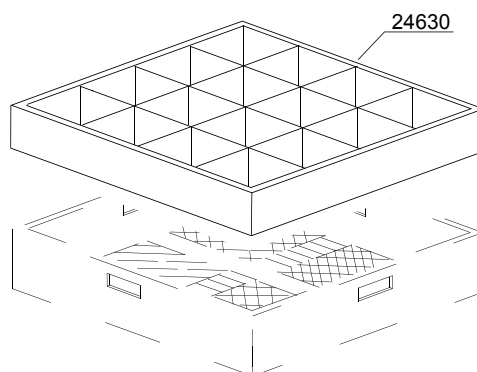
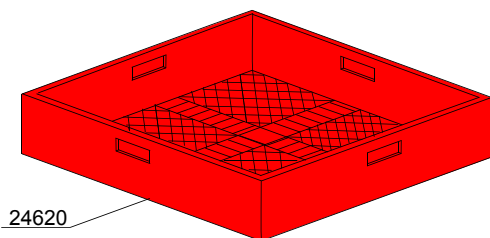
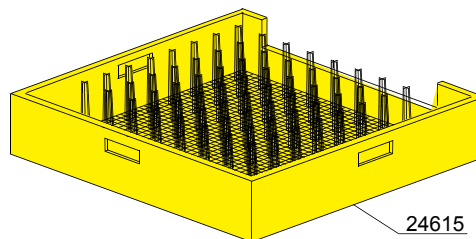
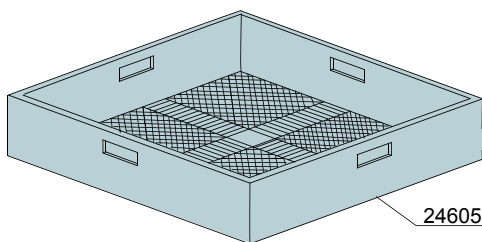
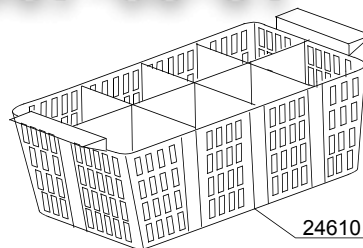
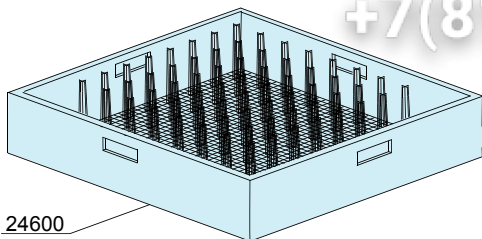

00_001_e

ID	P-code	SN from	SN to	Mod.	Acces.	Volt	Description
Module:Baskets [161,290,1700,2700]							
24600	C40		-				Place conveyor basket
24605	C41		-				Tight mesh conveyor basket for cutlery
24610	C47		-				Small 8 place cutlery basket
24615	C43		-				535mm tray conveyor basket
24620	C44		-				Mod.07 universal conveyor basket
24625	C112		-				5x5 vertical glass conveyor basket
24630	C113		-				4x4 vertical glass conveyor basket
24635	C114		-				6x6 vertical glass conveyor basket

em=ELECTROMECHANICAL SWITCHES, e=ELECTRONICAL SWITCHES, uw=LOWER AND UPPER WASHER
91=91

hr=HEAT RECOVERY - TR98, hr=HEAT RECOVERY - TR71, sc8=STEAM CONDENSER - LC 81, sc8=STEAM CONDENSER - LC 71, d9=DRYER - LC 90, sz8=SPLASH ZONE - LC 83, ti=TANK INSULATION, ds=DOUBLE SKIN, bp=BOOSTER PUMP, sdn3=DISPENSER SYSTEM SDN-3, 98=ANGLE LOADING TABLE - LC 98

A=3/N/PE~380-400V 50-60Hz, D=3/PE~200-210V 50-60Hz, F=2/PE~220-240V 50-60Hz, G=3/N/PE~415V 50-60Hz, H=3/PE~220-230V 50-60Hz, K=3/PE~380-400V 50-60Hz, L=3/PE~415V 50-60Hz, M=3/PE~440V 60Hz, P=1/N/PE~220-230V 50-60Hz, R=2/PE~220-240V 50-60Hz, U=1/N/PE~240V 50-60Hz, V=3/PE~240V 50-60Hz, W=1/N/PE~100-110V 50-60Hz

vsezip.ru

+7(812)987 08-81

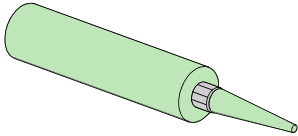
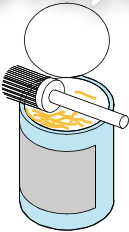
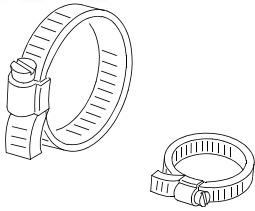
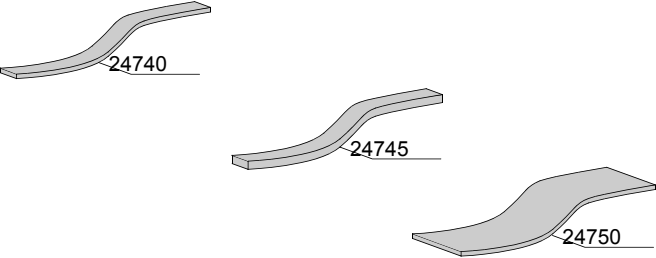
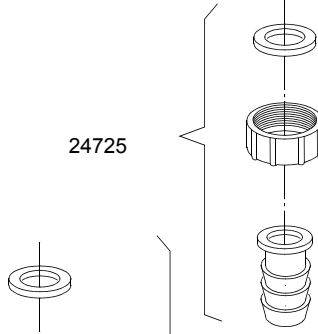
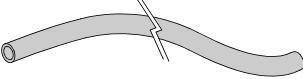
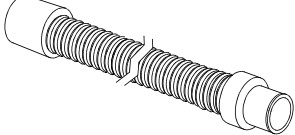
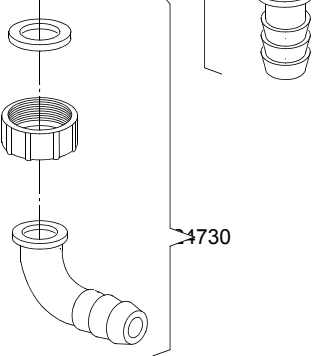
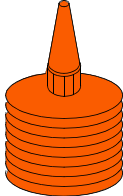
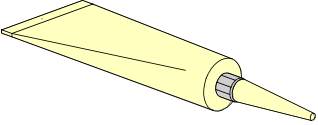
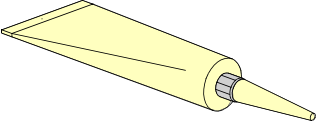
 <p>24700</p>	 <p>24705</p>	 <p>24760</p>
 <p>24740 24745 24750</p>		 <p>24725</p>
 <p>24755</p>	 <p>24735</p>	 <p>24730</p>
 <p>24765</p>	 <p>24770</p>	 <p>24775</p>

ID	P-code	SN from	SN to	Mod	Acces	Volt	Description
Module: Accessory [161,290,1700,2700]							
24700	---		-				Silicone UNI 9610 - UNI 9611
24705	---		-				Grease for high temperatures CCIAA 629224
24705	---		-				Grease for food - Loctite 8104 Cat. N° 26560
24725	15613/A		-				Fitting exauster
24730	15613		-				1" 1/4x30 nylon elbow
24735	10727		-				Exauster pipe Ø 24mm
24735	10200112		-				Exauster pipe Ø 32mm
24740	15750		-				20x2 self-stick mousse
24745	15751		-				20x4 self-stick mousse
24750	15752		-				60x2 self-stick mousse
24755	2907350		-				Flexible pipe EPDM Ø12
24755	2907352		-				Flexible pipe EPDM Ø12 - WRAS
24755	2907353		-				Flexible pipe EPDM Ø12
24760	11807		-				Steel hose clamp 15/24
24760	11806		-				Steel hose clamp 25/40
24760	11810		-				Steel hose clamp 40/60
24760	11824		-				Steel hose clamp 50/70
24760	2902491		-				Steel hose clamp 60/80
24765	---		-				-50°C +150°C threads dope
24770	---		-				Loctite 542 Cat.N° 54246 - DIN-DVGW 86.02 e 125
24770	---		-				Loctite 243 Cat.N° 18937 - 19386
24775	---		-				Loctite 511 Cat.N° 24003 - DIN-DVGW 86.01 e 125
24775	---		-				Loctite 577 Cat.N° 25392

em=ELECTROMECHANICAL SWITCHES, e=ELECTRONICAL SWITCHES, uw=LOWER AND UPPER WASHER
91=91

hr=HEAT RECOVERY - TR98, hr=HEAT RECOVERY - TR71, sc8=STEAM CONDENSER - LC 81, sc8=STEAM CONDENSER - LC 71, d9=DRYER - LC 90, sz8=SPLASH ZONE - LC 83, ti=TANK INSULATION, ds=DOUBLE SKIN, bp=BOOSTER PUMP, sdn3=DISPENSER SYSTEM SDN-3, 98=ANGLE LOADING TABLE - LC 98

A=3/N/PE~380-400V 50-60Hz, D=3/PE~200-210V 50-60Hz, F=2/PE~220-240V 50-60Hz, G=3/N/PE~415V 50-60Hz, H=3/PE~220-230V 50-60Hz, K=3/PE~380-400V 50-60Hz, L=3/PE~415V 50-60Hz, M=3/PE~440V 60Hz, P=1/N/PE~220-230V 50-60Hz, R=2/PE~220-240V 50-60Hz, U=1/N/PE~240V 50-60Hz, V=3/PE~240V 50-60Hz, W=1/N/PE~100-110V 50-60Hz