

+7(812)987-08-81

PNC	Model	Ref.	Page	Notes	
201 007	HFR/E 410	a	1- 3	Friggitrice 1/2 modulo	} Zanussi
201 020	HFR/E 412	b	1- 3	Friggitrice a sbalzo	
201 008	HFR/E 810	c	1- 3	Friggitrice 1 modulo	
201 019	HFR/E 411	d	1- 2- 3	Friggitrice 1/2 modulo sollevam. automatico	
201 035	HFR/E 418	e	1- 3	Friggitrice 1/2 modulo 230V 3+N	
201036	HFR/E 818	f	1- 3	Friggitrice 1 modulo 230V 3+N	} Zoppas
211 007	ZFR/E 410	g	1- 3	Friggitrice 1/2 modulo	
211 020	ZFR/E 412	h	1- 3	Friggitrice a sbalzo	
211 008	ZFR/E 810	l	1- 3	Friggitrice 1 modulo	
211 019	ZFR/E 411	m	1- 2- 3	Friggitrice 1/2 modulo sollevam. automatico	
211 035	ZFR/E 418	n	1- 3	Friggitrice 1/2 modulo 230V 3+N	
211 036	ZFR/E 818	p	1- 3	Friggitrice 1 modulo 230V 3+N	

Indice

Pag. 1	Tank-shelf and components
2	Lift baskets components
3	Electrical components
4-6	Spare parts list

Index

Ripiano-vasca e componenti
Componenti sollevamento cestelli
Componenti elettrici
Lista ricambi

Marchio / Brand: Z - P
Paese / Country: Tutti / All
Factory code: 9731

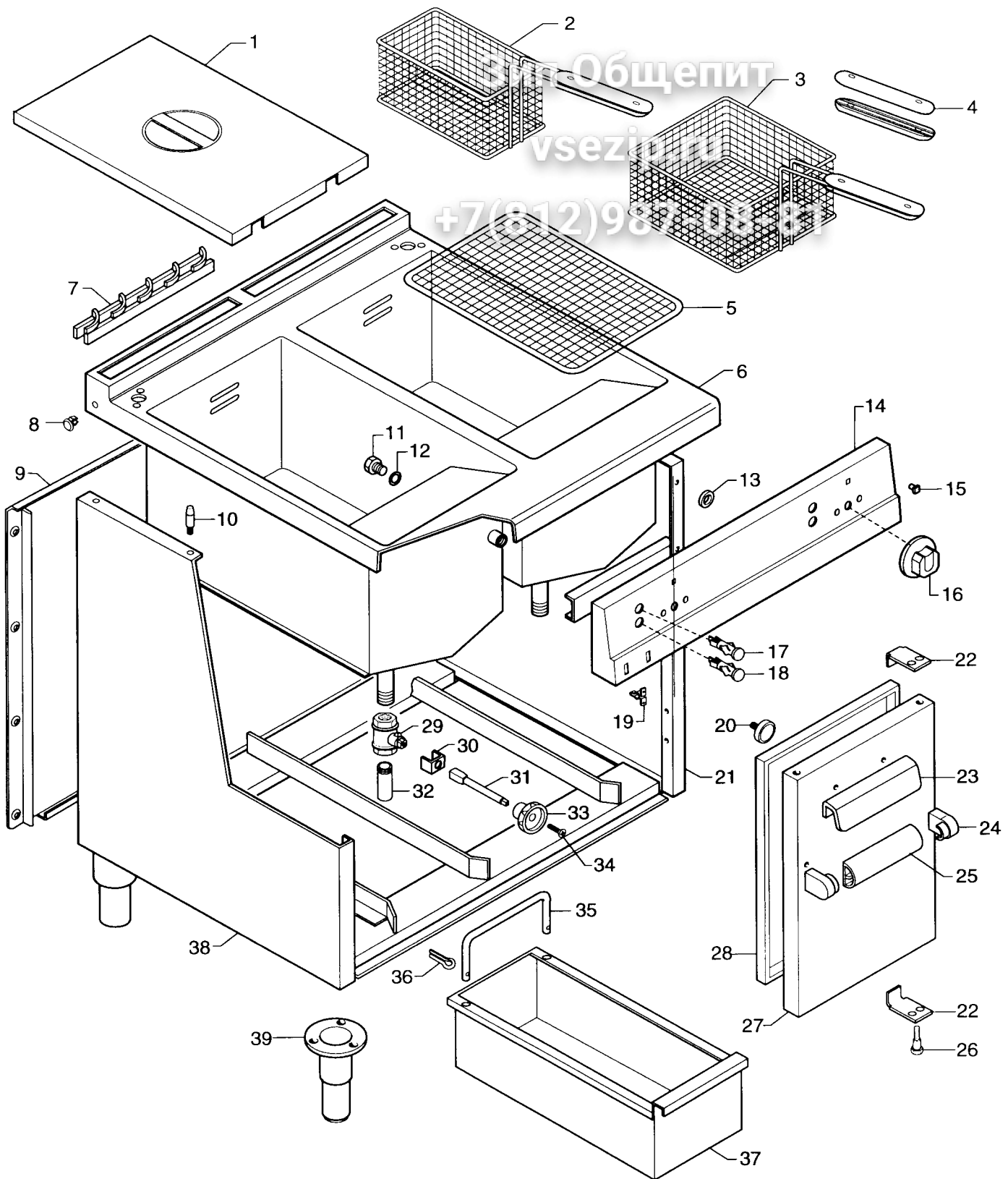

FRIGGITRICE ELETTRICA
ELECTRIC FRYER

Da Ser. Nr. / From ser. nr.: 301.....

Page: 1

Ed. 9912

Doc. Nr.:

2 - 21 702

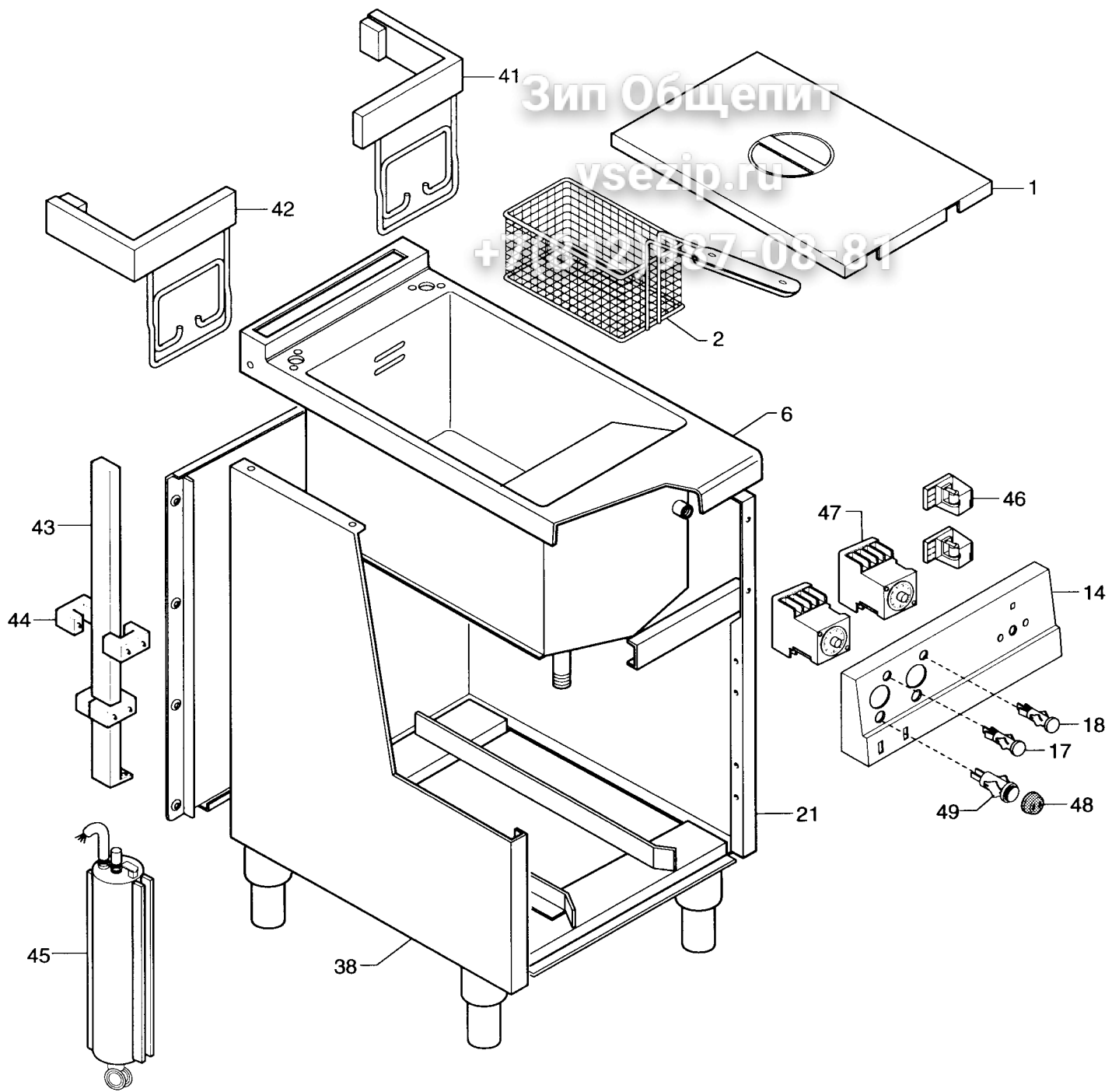

FRIGGITRICE ELETTRICA SOLLEVAMENTO AUTOMATICO CESTELLI
ELECTRIC FRYER AUTOMATIC LIFT BASKETS

Da Ser. Nr. / From ser. nr.: 301.....

Page: 2

Ed. 9912

Doc. Nr.: **2 - 21 702**

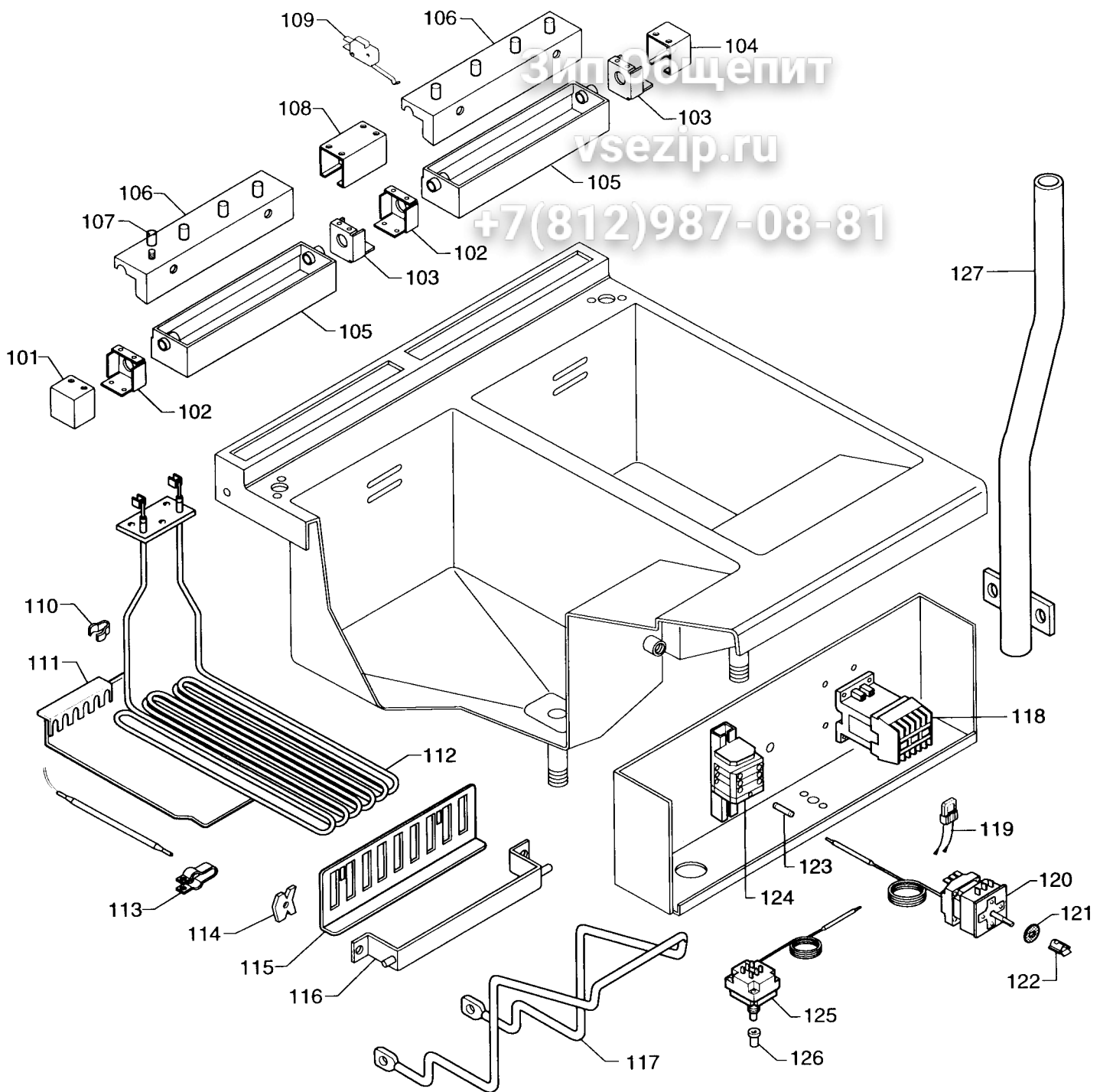

zip щепит
 vsezip.ru

+7(812)987-08-81

FRIGGITRICE ELETTRICA
ELECTRIC FRYER