

Зип Общепит

vsezip.ru

+7(812)987-08-81

5

6

7

8

9

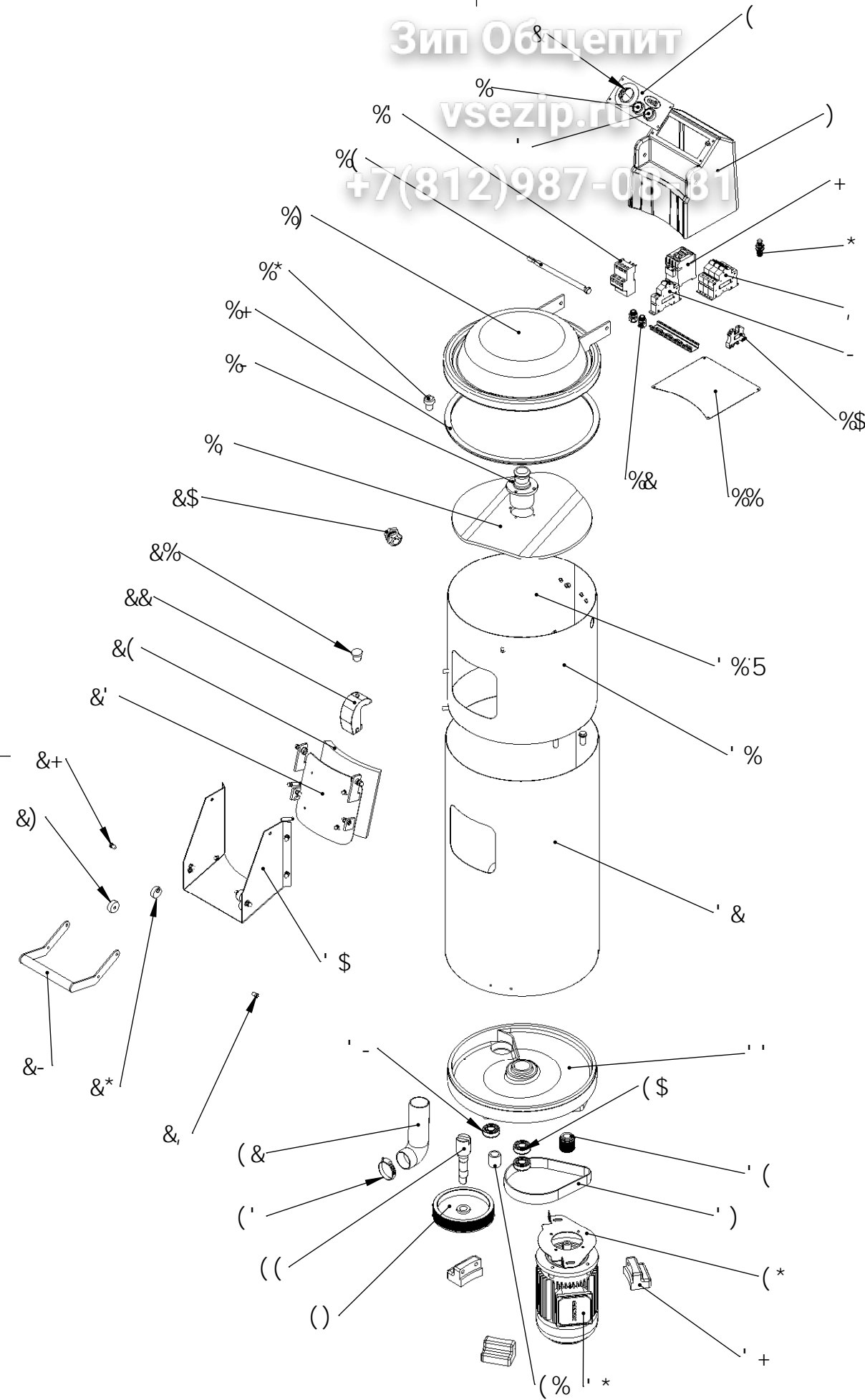

ÜBÖ	GA	A N5	H5F <	A 5H9F-5@	HC @F5BG
u N9B	G5M 5B		\$\$\$%&\$%		8-B '+% , "CFH5
?CBHFC @	Gu 5? F		\$\$\$%&\$%		
CB5M	A "<57 =		\$\$\$%&\$%	?5@B@?	F9J MCB \$
F9GA yN9F B89B x @y 5@A 5MB N	x @y@F a a 7 BGB89B F		5 f@? f fL		x @y?

¾ шт { cmlgt

D5Fu 5 58=

M9B 'DGA '30'D5H5H9G'GC MA 5'

\$, ("\$\$\$\$%" "\$\$\$\$" "\$M

POSITION NUMBER	PART CODE	Part Name
1	6232.00003.02	BUTTON START EMAS
2	6259.00002.00	TIMER DIHEL 4 MIN
3	6232.00003.06	BUTTON STOP EMAS
4	2840.00010.50	CANOPY
5	2840.00010.51	PLASTIC CANOPY
6	6232.00006.00	SWITCH
7	6230.00017.01	CONTACTOR GMC-9M 10 220 VAC
10	6248.00009.00	CABLE TERMINAL
11	2840.00010.52	BOTTOM SHEET
12	6259.00003.08	RECORD
13	6231.00001.01	THERMIC RELAY GTK-12M 1,6-2,5 LG
14	2840.00010.53	COVER MILE
15	2840.00030.11	TRANSPARENT COVER
16	2840.00010.05	UPPER COVER HANDLE
17	6261.00010.11	LAMEL ELEMENT
18	2840.00030.03	BOTTOM DISK
19	2840.00030.12	DISK HOLDING HANDLE
19-A	2840.00030.04	
20	2840.00010.15	WATER INTAKE GLAND
21	2840.00010.06	COVER LOCK HANDLE
22	2840.00010.07	COVER LOCK HANDLE
23	2840.00030.08	FRONT LID
24	6261.00010.04	POLIAMIDE ROLLER FOR FRONT LID
25	2840.00010.19	WHELL
26	2840.00010.20	COVER ROLLER
27	2840.00010.58	WHELL SCREW
28	2840.00010.59	COVER WHELL SCREW
29	2840.00030.09	COMPLETE HANDLE FOR FRONT LID
30	2840.00030.07	FRONT BASIN
31	2840.00030.02	INTERNAL BOWL
32	2840.00030.06	BODY
33	2840.00030.15	MIDDLE MOTOR CONNECTION
34	2840.00020.10	MOTOR WHELL
35	6263.00006.02	MOTOR BELT
36	6252.00000.51	MOTOR TRIFASE
36	PSM30-036-MONOFASE	MOTOR MONOFASE (ON REQUEST)
37	6261.00013.07	PLASTIC FOOT
38	6261.00010.01	PLASTIC FOOT
39	6228.00011.12	NUTRING 25*42*10
40	6211.00222.00	6204 ZZ BEARING
41	2840.00030.19	BEARING PART
42	2840.00020.23	DRAIN CONNECTOR
43	6221.00003.03	CONNECTOR CLAMP
44	2840.00030.20	BOTTOM DISC SHAFT
45	2840.00020.11	PULLEY
46	2840.00020.12	MOTOR FLANGE