

Зип Ощепит

vsezip.ru

+7(812)987-08-81

HOOD TYPE MACHINE

INSULATED HOOD
ELECTROMECHANICAL SWITCHES

TYPE: H63U

Accessories

BREAK TANK

BOOSTER PUMP

DVGW

WATER SOFTNER

DETERGENT DISPENSER

DRAIN PUMP

Spare parts manual

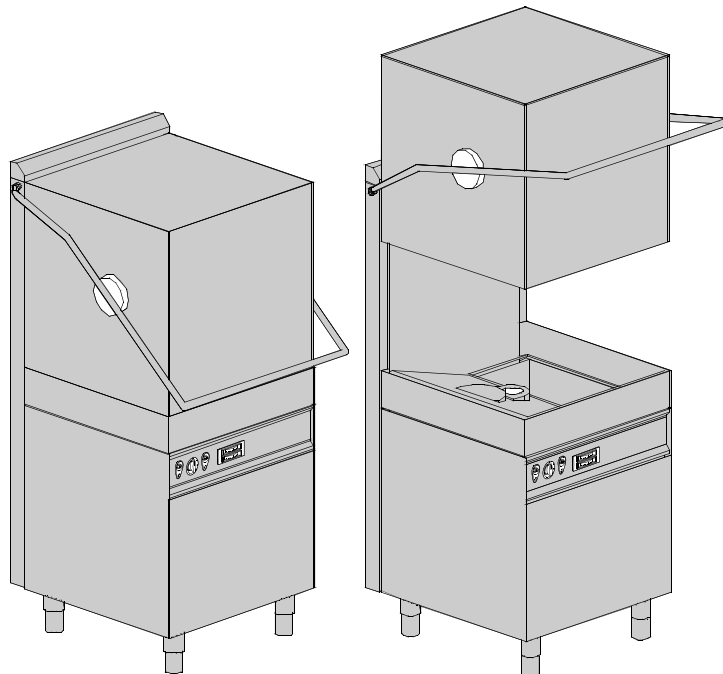

INFORMAZIONI GENERALI

Questo catalogo serve per richiedere con esattezza le parti di ricambio

Nelle ordinazioni indicare:

1) il numero dei codici dei particolari seguito dalla descrizione e la quantità desiderata;

2) Il codice alfa-numerico presente nella seconda colonna della tabella ;

I disegni delle parti di ricambio sono solo indicativi e non rappresentano il pezzo in oggetto.

I dati contenuti in questo catalogo sono indicativi e possono essere soggetti a modifiche senza impegno di preavviso.

ALLGEMEINE INFORMATIONEN

Dieser Ersatzteilkatalog dient zur genauen Angabe der Teile bei Ersatzteilbestellungen.

Bei Ersatzbestellung ist folgendes anzugeben:

1) Die Bestellnummer der Ersatzteile mit der entsprechenden Beschreibung genaue Menge;

2) Der alpha-numerischer Code auf der zweiten Reihe in dein Schuld;

Die Zeichnungen der Ersatzteile sind nur als Hinweise gedacht und stellen nicht das betroffene Teil dar.

Bei den im Katalog angeführten Daten handelt es sich um Anhaltsdaten, die jederzeit, ohne Vorankündigung, geändert werden können.

GENERAL INFORMATION

The present spare parts order exactly the right spare parts

When ordering specify:

1) the part's code number followed by its description and quantity needed;

2) The alpha-numeric code is in the second column in the chart;

Spare parts drawings are general and do not represent the part.

The contents of this catalogue are general and can undergo changes without prior notice.

INFORMACIONES GENERALES

El presente catálogo sirve para pedir con exactitud las partes de repuesto

En los pedidos se debe indicar:

1) el número de código de la parte y a continuación la descripción cantidad deseada;

2) El código alfanumerico presente en la segnada columna de la tabla;

Los diseños de las partes de recambio son solo indicativos y no representan la pieza en cuestión.

Los datos contenidos en el presente catálogo son indicativos y pueden modificarse sin aviso previo.

INFORMATIONS GENERALES

Ce catalogue permet de commander correctement les pièces détachées

Les commandes doivent être passées en indiquant:

1) le numero de code des pièces détachées suivi de leur description quantité désirée;

2) le code alphanumérique dans la deuxième colonne du tableau;

Les plans des pièces détachées sont fournis seulement à titre indicatif et ne représentent pas la pièce concernée.

Les données de ce catalogue sont citées seulement à titre indicatif et peuvent être l'objet de modifications sans avis préalable.

**ESEMPIO
EXAMPLE
EXEMPLE
BEISPIEL**

Rif.	Codici
MODULE:Particolari	
10505	540903
10510	540908
10515	15065/A
10520	540086
10525	540028



Note

Tutte le informazioni riportate si intendono aggiornate alla data di stampa. Il Produttore si riserva il diritto di apportare qualsiasi modifica richiesta dallo sviluppo evolutivo dei suddetti prodotti.

Per la sicurezza, la garanzia, l'affidabilità ed il valore della lavastoviglie usa solo ricambi originali. **Per alcuni codici, sono richieste quantità minime d'ordine.**



Attenzione

Questo libretto è parte integrante della lavastoviglie e, in caso di passaggio di proprietà, deve essere consegnato al nuovo acquirente.



Remarque

Toutes les informations contenues dans ce manuel s'entendent mises à jour à la date d'impression. En raison du développement constant de ses produits, usine se réserve le droit d'apporter à tout instant les modifications qu'elle jugera utiles.

Pour la sécurité, la garantie, la fiabilité et la valeur de votre lavevaisselles n'utilisez que des pièces de rechange d'origine. **Pour quelque référence on demande un minimum de pièces par commande**



Attention

Ce manuel doit être considéré comme partie intégrante de la lavevaisselles, en cas de transfert de propriété, doit toujours être remis au nouveau propriétaire.



Note

The information contained herein is valid at the time of going to print. The Company reserves the right to make any changes required by the future development of the above-mentioned products.

For your safety, as well as to preserve the warranty reliability and worth of your dishwashers, use original spare parts only. **For some codes a minimum quantity for order is required.**



Warning

This manual forms an integral part of the dishwashers and - if a transfer of title occurs - must always be handed over to the new owner.



Hinweis

Die Der Hersteller behält sich das Recht vor, jegliche, durch eine Weiterentwicklung der genannten Produkte bedingte Änderungen vornehmen zu können.

Verwenden Sie für Ihre Sicherheit, die Garantie, die Zuverlässigkeit und den Wert Ihrer machine originale Ersatzteile. **Für bestimmte Code nummer werden mindesten bestellungen verlangt.**



Achtung

Diese Betriebsanleitung ist Bestandteile des machine und muss bei seinem Weiterverkauf dem neuen Besitzer ausgehändigt werden.



+7(812)987-08-81



Code DW 999XXYYYY **CL/Part**

Model DESCRIPTION

S/N DW A 1015770 Type

400V 3N 50HZ 8A
3500W 500W

IPX3  16A

Pressione Dinamica alimentazione idrica **200-500 kPa**

Pression dynamique arrivée d'eau

Dynamic pressure water supply

Dynamischer Druck asserreinlauf

Pressione dinamica vapore saturo

Pression dynamique vapore satueèè

Dymanischer Druck gesattigter Dampf

Pression Dinamica Vapor Saturado

TECHICAL SPECIFICATION



MADE IN ITALY

Temperatura massima acqua in ingresso **60°C**

Temperature max eau a l'entre

Maximale Temperatur Wasseranschlü

Maximum Water temperature in-feeding

Model 

S/N 



Spare parts

Зип Общепит

vsezip.ru

+7(812)987-08-81

vsezip.ru

+7(812)987-08-81

1. Spare parts

General body parts.....	9
Closing panelig.....	11
Control panel and switches.....	15
Electric control components.....	17
Solenoid valve group	19
Solenoid valve group	21
Break Tank	23
Booster pump.....	25
Booster pump.....	27
DVGW	29
Water softner group.....	31
Rinse aid dispenser group.....	33
Boiler group	35
3 ways connection	37
Wash pump group.....	39
Dosing detergent group.....	41

Drain pump group..... 43

Pressure switch group with air trap... 45

Turret group with rotating arms 47

Turret group with rotating arms 49

1.1 Voltage codes

Volt	Voltage code
A	3/N/PE~380-400V 50-60Hz
D	3/PE~200-210V 50-60Hz
F	2/PE~220-240V 50-60Hz
G	3/N/PE~415V 50-60Hz
H	3/PE~220-230V 50-60Hz
K	3/PE~380-400V 50-60Hz
L	3/PE~415V 50-60Hz
M	3/PE~440V 60Hz
P	1/N/PE~220-230V 50-60Hz
R	2/PE~220-240V 50-60Hz
U	1/N/PE~240V 50-60Hz
V	3/PE~240V 50-60Hz
W	1/N/PE~100-110V 50-60Hz

1.2 Product codes

Product code	Full name
Model codes	
i	INSULATED HOOD
em	ELECTROMECHANICAL SWITCHES
Type codes	
H63U	H63U
Accessory codes	
bt	BREAK TANK
bp	BOOSTER PUMP
dvgw	DVGW
ws	WATER SOFTNER
dd	DETERGENT DISPENSER
dp	DRAIN PUMP

vsezip.ru

+7(812)987-08-81

01_028_e

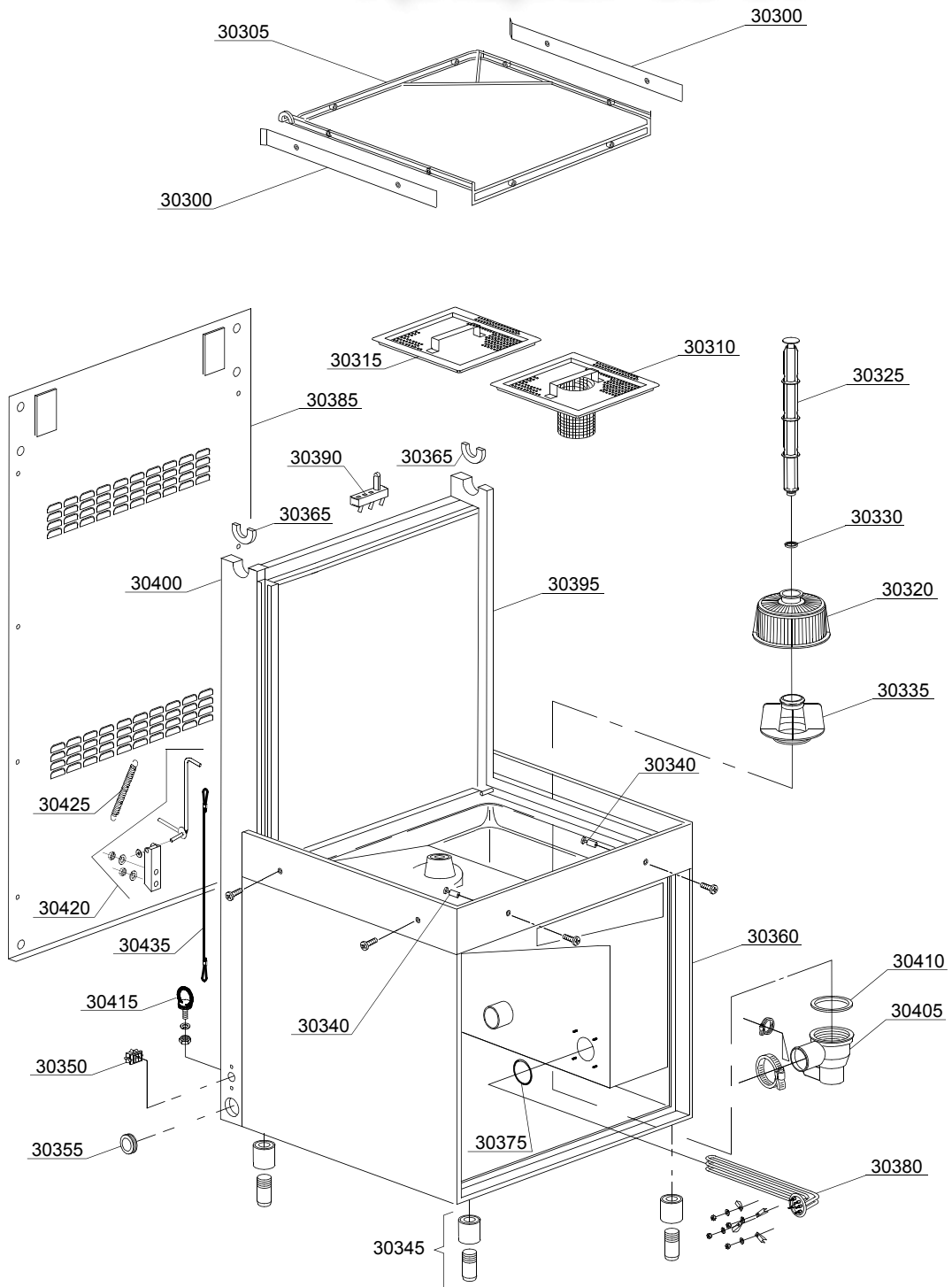

ID	P-code	SN from	SN to	Mod.	Acces.	Volt	Description
Module:General body parts							
30300	10600923		-				Guide rail
30305	11600001		-				Rack frame
30310	11600906		-				Strainer plate with a strainer box
30315	11600907		-				Strainer plate
30320	500616		-				Suction filter
30325	11600102		-				Overflow pipe
30330	13021		-				DEM 40 O-ring
30335	500615		-				Ferrule with filter
30340	11600018		-				Basket support holder pin M6
30345	15116		-				Foot
30350	15065/A		-				Cable-fastener with screw
30355	13324		-				Cable screw cap
30360	11600960		-				Frame assembly
30365	11600055		-				Right/left slide bearing
30375	13015		-				O-ring
30380	15047/A		-				2,7/2,94KW 230/240V 3 heating element
30385	11600630		-				Back panel
30390	70305		-				Hood switch
30395	11600620		-				Right guide rail support
30400	11600621		-				Left guide rail support
30405	500605		-				Outlet connction
30410	80208		-				95x75x3 O-ring
30415	11600058		-				Passage ring for the security cord
30420	11600059		-				Support for the security system assembly
30425	10700		-				Spring
30435	11600057/A		-				Securty system cord

i=INSULATED HOOD, em=ELECTROMECHANICAL SWITCHES

H63U=H63U

bt=BREAK TANK, bp=BOOSTER PUMP, dvgw=DVGW, ws=WATER SOFTNER, dd=DETERGENT DISPENSER, dp=DRAIN PUMP

A=3/N/PE~380-400V 50-60Hz, D=3/PE~200-210V 50-60Hz, F=2/PE~220-240V 50-60Hz, G=3/N/PE~415V 50-60Hz, H=3/PE~220-230V 50-60Hz, K=3/PE~380-400V 50-60Hz, L=3/PE~415V 50-60Hz, M=3/PE~440V 60Hz, P=1/N/PE~220-230V 50-60Hz, R=2/PE~220-240V 50-60Hz, U=1/N/PE~240V 50-60Hz, V=3/PE~240V 50-60Hz, W=1/N/PE~100-110V 50-60Hz

vsezip.ru

+7(812)987-08-81

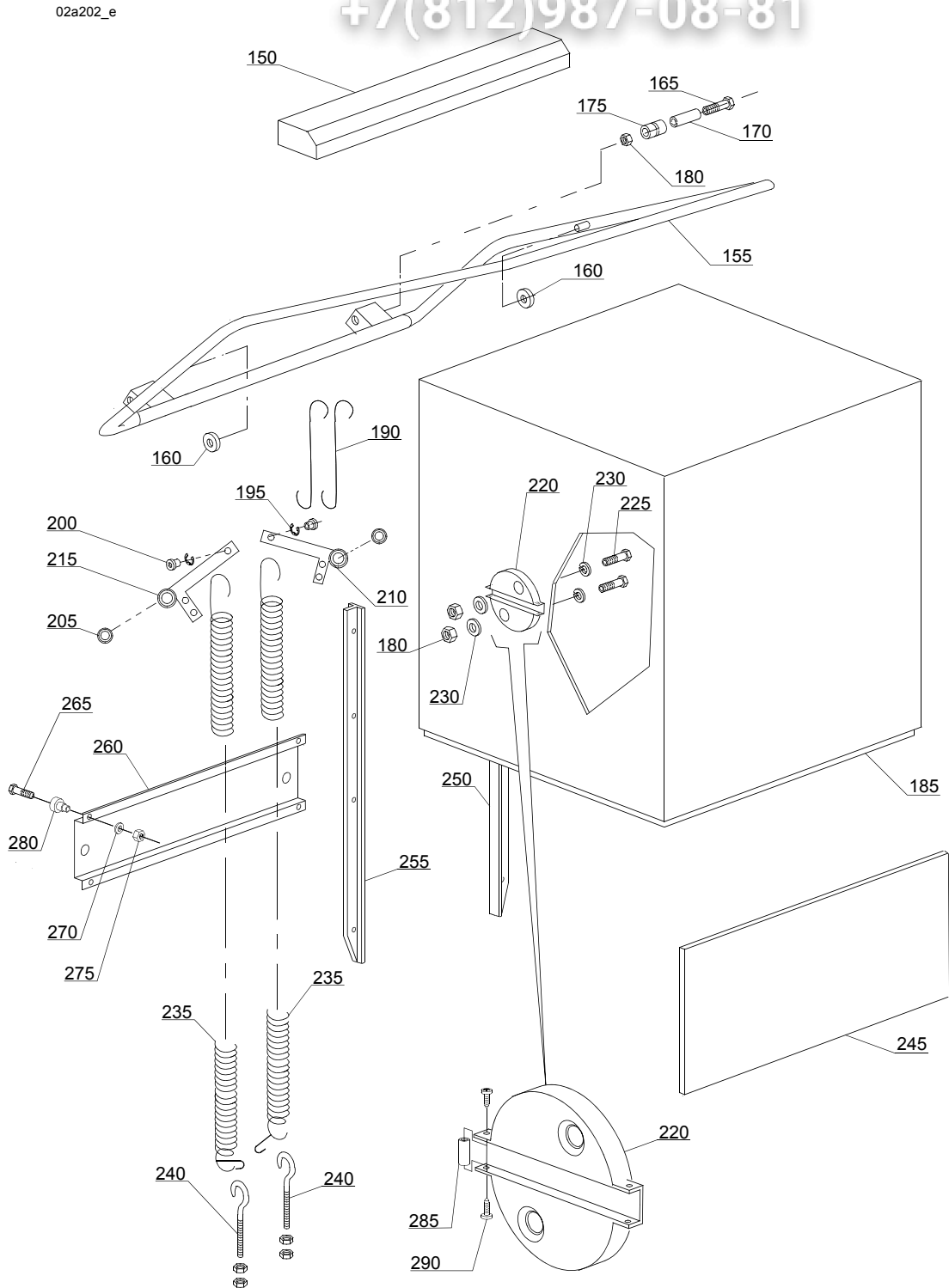

ID	P-code	SN from	SN to	Mod.	Acces.	Volt	Description
Module: Closing panelig							
150	11600913		-				Guide
155	11600910		-				Handle
160	89919		-				Bearing
165	11214		-				Screw
170	11600015		-				Filter
175	11600014		-				Roller
180	11718		-				M8 stainless steel self-locking nut
185	11600925		-				Hood, complete
190	11600013		-				Hook
195	11823		-				Ø10 stainless steel snap ring
200	11600038		-				Spring bush
205	10800010		-				Bearing 6002 2RS
210	11600026		-				Elbow, right
215	11600027		-				Elbow, left
220	11600030		-				Bearing holder
225	11110		-				Screw
230	13301		-				Gasket Ø 14x8x1,5
235	70302		-				Hood spring
240	10800210		-				Hook screw
245	11600616		-				Front plate
250	11600028		-				Guide, right
255	11600029		-				Guide, left
260	11600624		-				Leavers bearing foor hood
265	11134		-				M10x35 TE Stainless steel screw
270	11192		-				M10 Stainless steel epring washer
275	11719		-				M10 inox nut
280	10800115		-				Lifting rod pin
285	76251		-				Spacer

i=INSULATED HOOD, em=ELECTROMECHANICAL SWITCHES

H63U=H63U

bt=BREAK TANK, bp=BOOSTER PUMP, dvgw=DVGW, ws=WATER SOFTNER, dd=DETERGENT DISPENSER, dp=DRAIN PUMP

A=3/N/PE~380-400V 50-60Hz, D=3/PE~200-210V 50-60Hz, F=2/PE~220-240V 50-60Hz, G=3/N/PE~415V 50-60Hz, H=3/PE~220-230V 50-60Hz, K=3/PE~380-400V 50-60Hz, L=3/PE~415V 50-60Hz, M=3/PE~440V 60Hz, P=1/N/PE~220-230V 50-60Hz, R=2/PE~220-240V 50-60Hz, U=1/N/PE~240V 50-60Hz, V=3/PE~240V 50-60Hz, W=1/N/PE~100-110V 50-60Hz

vsezip.ru

+7(812)987-08-81

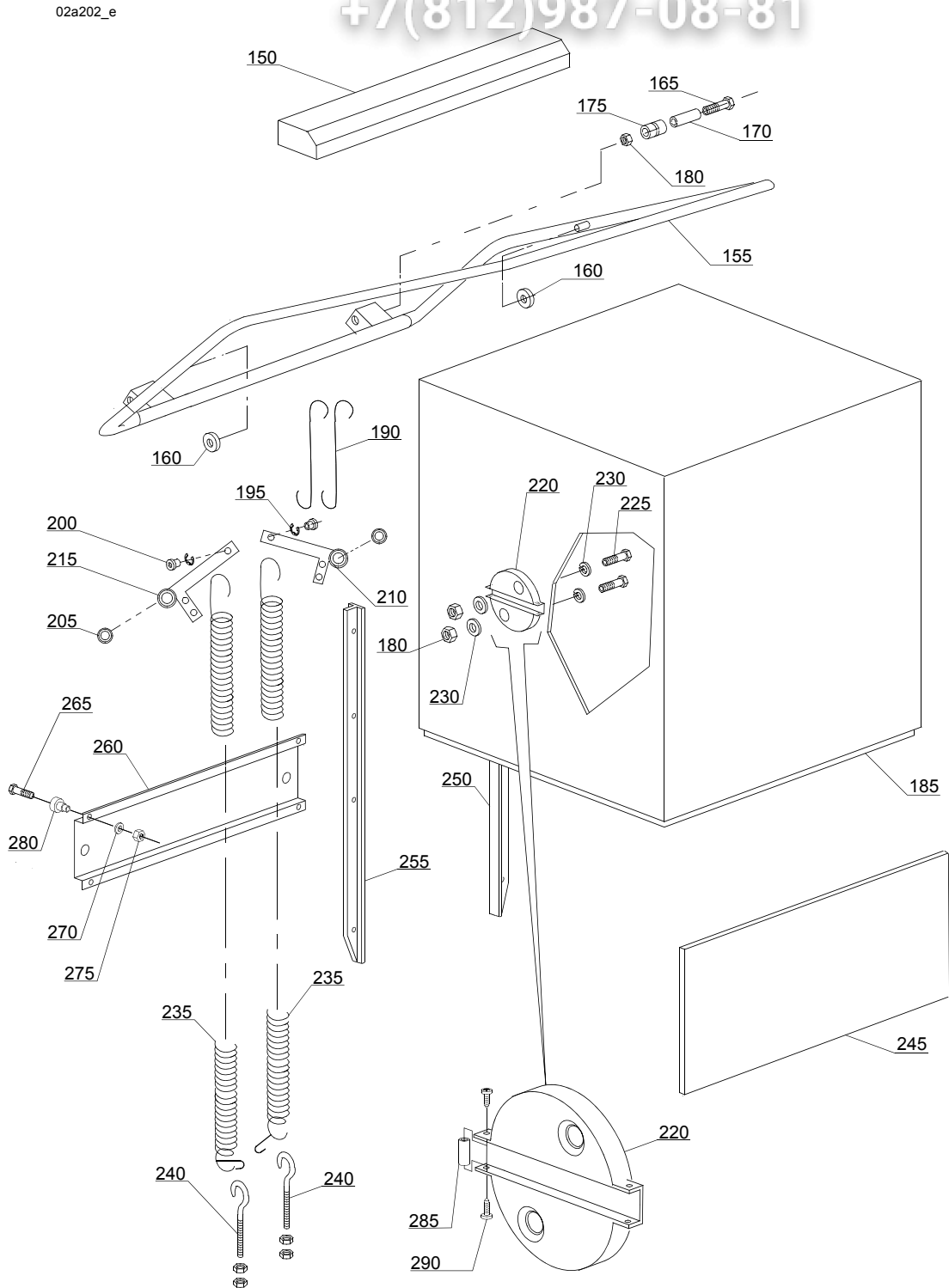

vsezip.ru

ID	P-code	SN from	SN to	Mod.	Acces.	Volt	Description
Module: Closing panelig							
290	11121		-				M4x10 TCB Inox screw

i=INSULATED HOOD, em=ELECTROMECHANICAL SWITCHES

H63U=H63U

bt=BREAK TANK, bp=BOOSTER PUMP, dvgw=DVGW, ws=WATER SOFTNER, dd=DETERGENT DISPENSER, dp=DRAIN PUMP

A=3/N/PE~380-400V 50-60Hz, D=3/PE~200-210V 50-60Hz, F=2/PE~220-240V 50-60Hz, G=3/N/PE~415V 50-60Hz, H=3/PE~220-230V 50-60Hz, K=3/PE~380-400V 50-60Hz, L=3/PE~415V 50-60Hz, M=3/PE~440V 60Hz, P=1/N/PE~220-230V 50-60Hz, R=2/PE~220-240V 50-60Hz, U=1/N/PE~240V 50-60Hz, V=3/PE~240V 50-60Hz, W=1/N/PE~100-110V 50-60Hz

vsezip.ru

+7(812)987-08-81

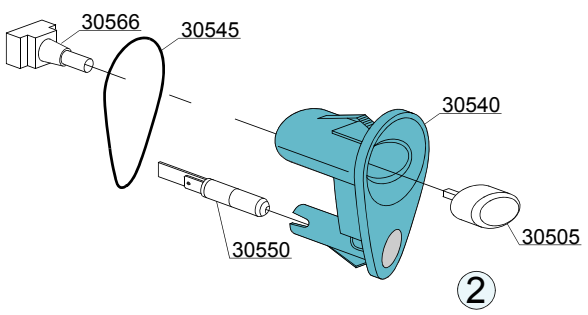
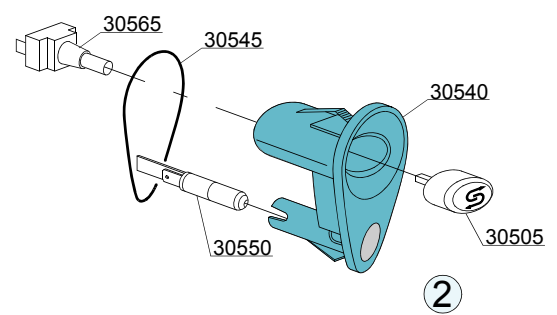
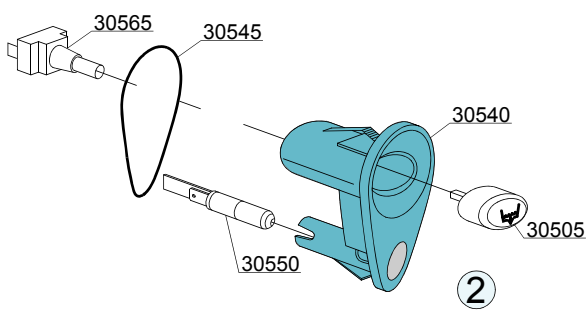
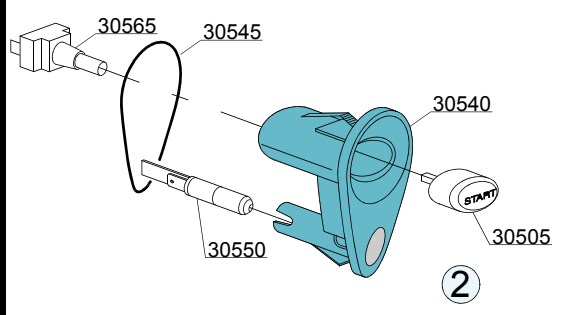
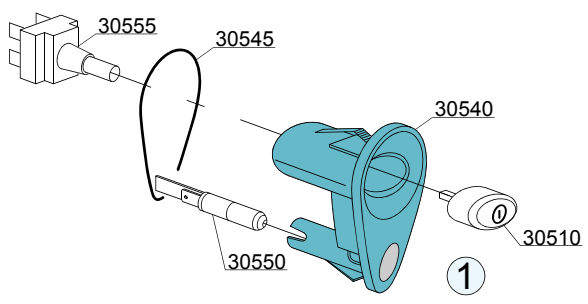
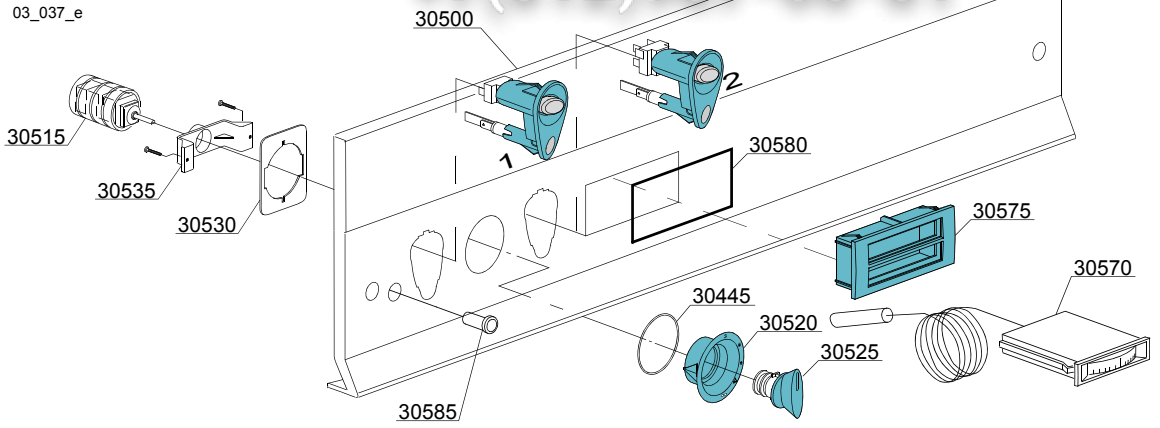

ID	P-code	SN from	SN to	Mod.	Acces.	Volt	Description
Module:Control panel and switches							
30500	11600950		-	em			Control panel
30505	89341		-	em			Start push button
30505	89348		-	em			Blind push button
30505	89345		-	em			Regeneration push button
30505	89343		-	em			Drain pump push button
30510	89340		-	em			ON-OFF push button
30515	10300208		-	em			Rotating selector switch
30520	89349		-	em			Selector switch support
30525	89321		-	em			Selector switch handle control
30530	89323		-	em			Screw retainer
30535	89322		-	em			Selector switch screw retainer support
30545	89300		-	em			Push button support
30545	89332		-	em			OR O-ring
30550	15826		-	em			Pilot light
30555	15800		-	em			16A bipolar switch
30555	15812		-	em			16A switch
30565	15813		-	em			16A unipolar switch
30566	15844		-	em			Push button support
30570	10500011		-	em			Thermometer
30575	89306		-	em			Double thermometer support
30580	89331		-	em			OR O-ring
30585	10711/B		-	em			Pilot light

i=INSULATED HOOD, em=ELECTROMECHANICAL SWITCHES

H63U=H63U

bt=BREAK TANK, bp=BOOSTER PUMP, dvgw=DVGW, ws=WATER SOFTNER, dd=DETERGENT DISPENSER, dp=DRAIN PUMP

A=3/N/PE~380-400V 50-60Hz, D=3/PE~200-210V 50-60Hz, F=2/PE~220-240V 50-60Hz, G=3/N/PE~415V 50-60Hz, H=3/PE~220-230V 50-60Hz, K=3/PE~380-400V 50-60Hz, L=3/PE~415V 50-60Hz, M=3/PE~440V 60Hz, P=1/N/PE~220-230V 50-60Hz, R=2/PE~220-240V 50-60Hz, U=1/N/PE~240V 50-60Hz, V=3/PE~240V 50-60Hz, W=1/N/PE~100-110V 50-60Hz

vsezip.ru

+7(812)987-08-81

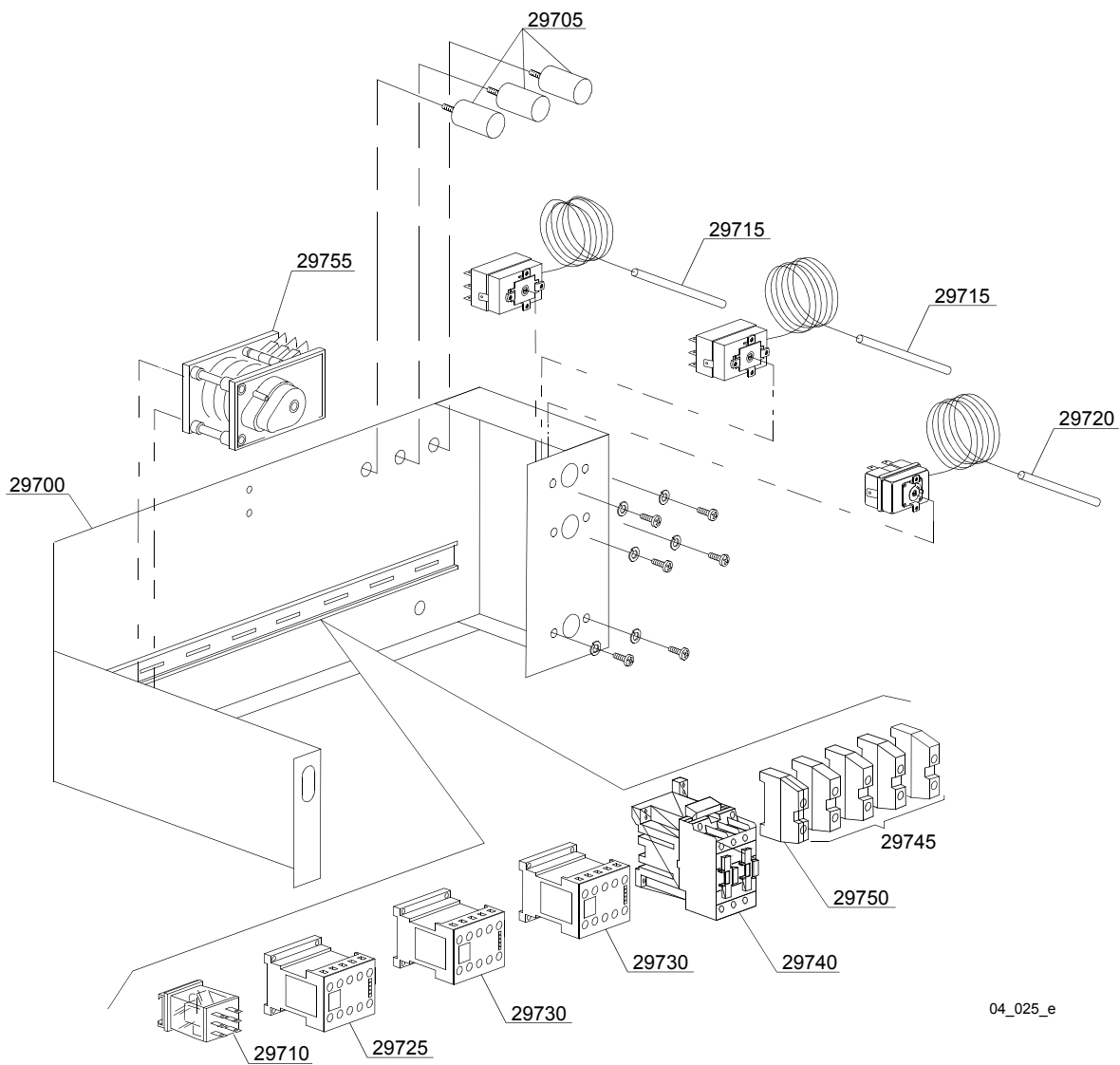
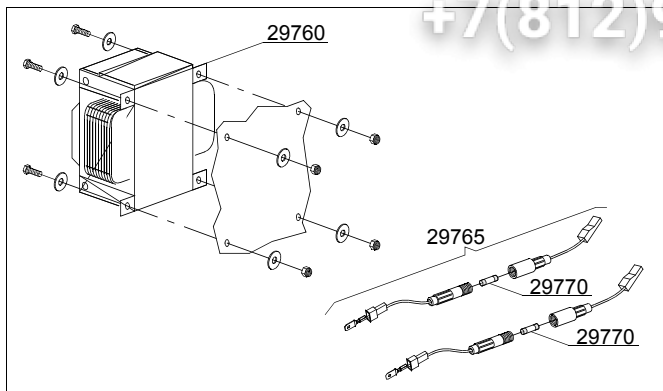

04_025_e

ID	P-code	SN from	SN to	Mod	Acces.	Volt	Description
Module: Electric control components							
29700	11600955		-	em			Electric component panel
29705	15149		-	em			Low noise filter
29710	560302		-	em	ws		Relay 230V 50/60Hz
29715	10707/1		-	em			0-90°C thermostat
29720	2000430		-	em			Overheat protector
29725	10300392		-	em			3NA/1NC contactor - 240Vac 50Hz
29730	15086		-	em			Contactor TLV, TLB
29730	15086/B		-	em			Contactor 240V 50Hz
29740	10300050		-	em			Contactor TLP
29740	10300052		-	em			36A/20A contactor - 230V 50/60HZ
29740	10300054		-	em			25A/16A contactor - 230V 50/60HZ
29745	10300401		-	em			Connecting piece
29750	10300403		-	em			Connecting piece
29755	10300122		-	em			50/100/150" timer

i=INSULATED HOOD, em=ELECTROMECHANICAL SWITCHES

H63U=H63U

bt=BREAK TANK, bp=BOOSTER PUMP, dvgw=DVGW, ws=WATER SOFTNER, dd=DETERGENT DISPENSER, dp=DRAIN PUMP

A=3/N/PE~380-400V 50-60Hz, D=3/PE~200-210V 50-60Hz, F=2/PE~220-240V 50-60Hz, G=3/N/PE~415V 50-60Hz, H=3/PE~220-230V 50-60Hz, K=3/PE~380-400V 50-60Hz, L=3/PE~415V 50-60Hz, M=3/PE~440V 60Hz, P=1/N/PE~220-230V 50-60Hz, R=2/PE~220-240V 50-60Hz, U=1/N/PE~240V 50-60Hz, V=3/PE~240V 50-60Hz, W=1/N/PE~100-110V 50-60Hz

vsezip.ru

+7(812)987-08-81

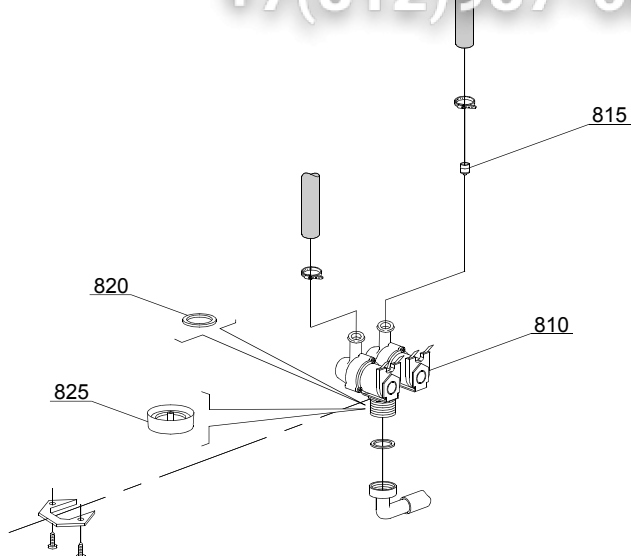

05_003_e

vsezip.ru

ID	P-code	SN from	SN to	Mod.	Acces.	Volt	Description
Module:Solenoid valve group							
810	15098		-	i,em	ws		Double solenoid valve - Ø10
815	15115		-	i,em	ws		Green pression solenoid valve
820	N.C.		-	i,em	ws		Pression reducing valve

i=INSULATED HOOD, em=ELECTROMECHANICAL SWITCHES

H63U=H63U

bt=BREAK TANK, bp=BOOSTER PUMP, dvgw=DVGW, ws=WATER SOFTNER, dd=DETERGENT DISPENSER, dp=DRAIN PUMP

A=3/N/PE~380-400V 50-60Hz, D=3/PE~200-210V 50-60Hz, F=2/PE~220-240V 50-60Hz, G=3/N/PE~415V 50-60Hz, H=3/PE~220-230V 50-60Hz, K=3/PE~380-400V 50-60Hz, L=3/PE~415V 50-60Hz, M=3/PE~440V 60Hz, P=1/N/PE~220-230V 50-60Hz, R=2/PE~220-240V 50-60Hz, U=1/N/PE~240V 50-60Hz, V=3/PE~240V 50-60Hz, W=1/N/PE~100-110V 50-60Hz

vsezip.ru

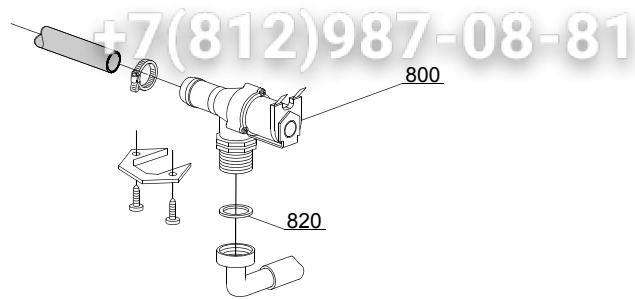

05_005_e

vsezip.ru

ID	P-code	SN from	SN to	Mod	Acces	Volt	Description
Module:Solenoid valve group							
800	30001000		-	i,em			Solenoid valve
820	N.C.		-	i,em			Pression reducing valve

i=INSULATED HOOD, em=ELECTROMECHANICAL SWITCHES

H63U=H63U

bt=BREAK TANK, bp=BOOSTER PUMP, dvgw=DVGW, ws=WATER SOFTNER, dd=DETERGENT DISPENSER, dp=DRAIN PUMP

A=3/N/PE~380-400V 50-60Hz, D=3/PE~200-210V 50-60Hz, F=2/PE~220-240V 50-60Hz, G=3/N/PE~415V 50-60Hz, H=3/PE~220-230V 50-60Hz, K=3/PE~380-400V 50-60Hz, L=3/PE~415V 50-60Hz, M=3/PE~440V 60Hz, P=1/N/PE~220-230V 50-60Hz, R=2/PE~220-240V 50-60Hz, U=1/N/PE~240V 50-60Hz, V=3/PE~240V 50-60Hz, W=1/N/PE~100-110V 50-60Hz

vsezip.ru

+7(812)987-08-81

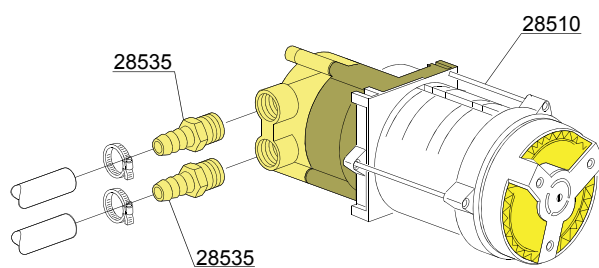
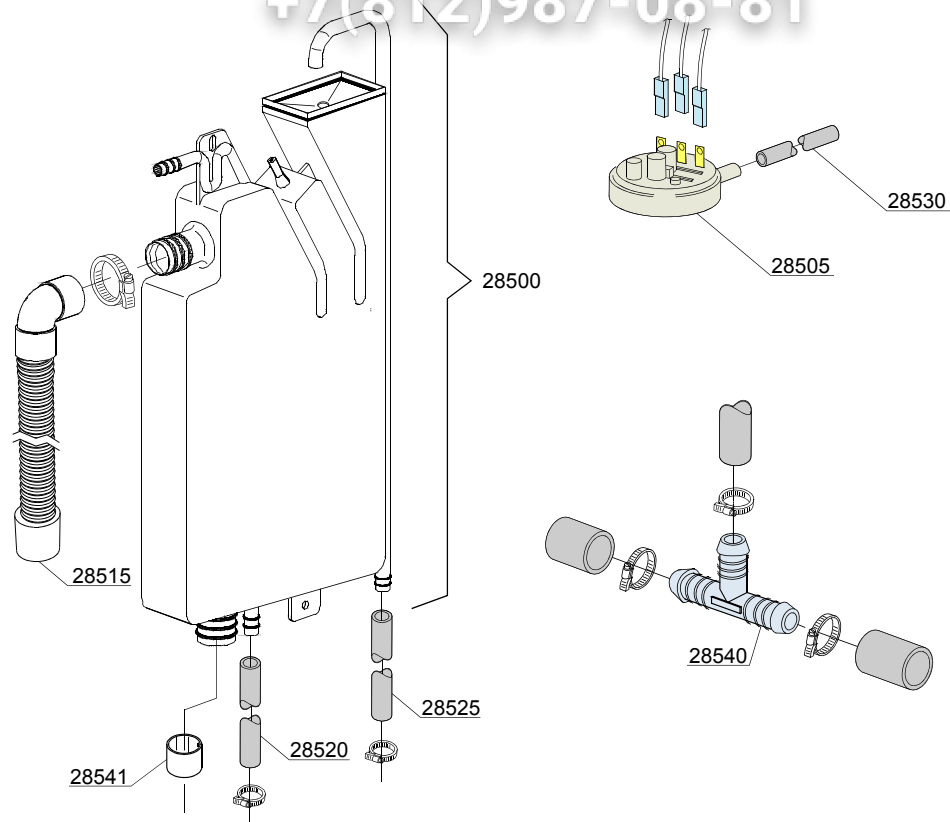

06_004pe

vsezip.ru

ID	P-code	SN from	SN to	Mod.	Acces.	Volt	Description
Module:Break Tank							
28500	15735		-	i,em	bt		Break tank assembly
28505	10706/A		-	i,em	bt		47-27 pressure switch
28510	15100/D		-	i,em	bt		Booster pump 220/240V - body pumps in brass
28515	15722		-	i,em	bt		BT middle pipe L=920
28520	2907350		-	i,em	bt		12x20 EPDM rubber hose
28525	2907352		-	i,em	bt		PVC WRAS rubber hose
28530	14508		-	i,em	bt		4,5x9 EPDM rubber hose (minimum 2 mt)
28535	10221311		-	i,em	bt		Rubber holder Ø 12 3/8G
28540	540098			i,em	bt		3 ways D25

i=INSULATED HOOD, em=ELECTROMECHANICAL SWITCHES

H63U=H63U

bt=BREAK TANK, bp=BOOSTER PUMP, dvgw=DVGW, ws=WATER SOFTNER, dd=DETERGENT DISPENSER, dp=DRAIN PUMP

A=3/N/PE~380-400V 50-60Hz, D=3/PE~200-210V 50-60Hz, F=2/PE~220-240V 50-60Hz, G=3/N/PE~415V 50-60Hz, H=3/PE~220-230V 50-60Hz, K=3/PE~380-400V 50-60Hz, L=3/PE~415V 50-60Hz, M=3/PE~440V 60Hz, P=1/N/PE~220-230V 50-60Hz, R=2/PE~220-240V 50-60Hz, U=1/N/PE~240V 50-60Hz, V=3/PE~240V 50-60Hz, W=1/N/PE~100-110V 50-60Hz

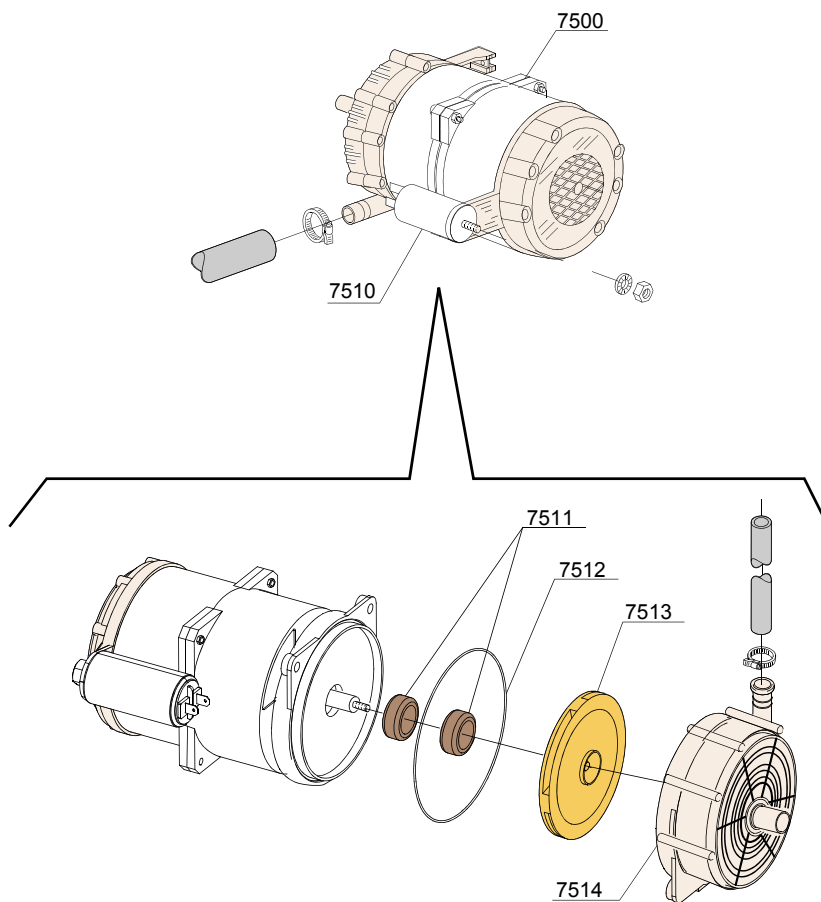

VERSIONE BREAK TANK / VERSIONE PLUS
BREAK TANK VERSION / SYSTEM PLUS VERSION
VERSION BREAK TANK / VERSION SISTEME PLUS

vsezip.ru

ID	P-code	SN from	SN to	Mod.	Acces.	Volt	Description
Module: Booster pump							
7500	15100/DO		-	i,em	bp		Booster pump 220/240V - body pumps in plastic
7510	10702		-	i,em	bp		5 uF condenser - 450V
7511	15100/S		-	i,em	bp		Rotating seals
7512	15100/T		-	i,em	bp		OR (O-ring) gasket EPDM
7513	15100/U		-	i,em	bp		Pump rotor
7514	15100/V		-	i,em	bp		Scroll

i=INSULATED HOOD, em=ELECTROMECHANICAL SWITCHES

H63U=H63U

bt=BREAK TANK, bp=BOOSTER PUMP, dvgw=DVGW, ws=WATER SOFTNER, dd=DETERGENT DISPENSER, dp=DRAIN PUMP

A=3/N/PE~380-400V 50-60Hz, D=3/PE~200-210V 50-60Hz, F=2/PE~220-240V 50-60Hz, G=3/N/PE~415V 50-60Hz, H=3/PE~220-230V 50-60Hz, K=3/PE~380-400V 50-60Hz, L=3/PE~415V 50-60Hz, M=3/PE~440V 60Hz, P=1/N/PE~220-230V 50-60Hz, R=2/PE~220-240V 50-60Hz, U=1/N/PE~240V 50-60Hz, V=3/PE~240V 50-60Hz, W=1/N/PE~100-110V 50-60Hz

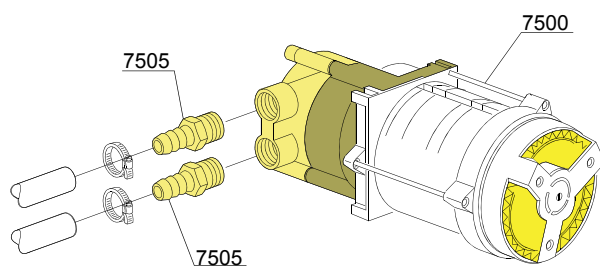

VERSIONE STANDARD / VERSIONE POMPA AUM. PRESSIONE
STANDARD VERSION / BOOSTER PUMP VERSION
VERSION STANDARD / VERSION POMPE AUGMENT. PRESSION

vsezip.ru

ID	P-code	SN from	SN to	Mod.	Acces.	Volt	Description
Module:Booster pump							
7500	15100/D		-	i,em,i	bp		Booster pump 220/240V - body pumps in brass
7505	10221311		-	i,em,i	bp		Rubber holder Ø 12 3/8G

i=INSULATED HOOD, em=ELECTROMECHANICAL SWITCHES

H63U=H63U

bt=BREAK TANK, bp=BOOSTER PUMP, dvgw=DVGW, ws=WATER SOFTNER, dd=DETERGENT DISPENSER, dp=DRAIN PUMP

A=3/N/PE~380-400V 50-60Hz, D=3/PE~200-210V 50-60Hz, F=2/PE~220-240V 50-60Hz, G=3/N/PE~415V 50-60Hz, H=3/PE~220-230V 50-60Hz, K=3/PE~380-400V 50-60Hz, L=3/PE~415V 50-60Hz, M=3/PE~440V 60Hz, P=1/N/PE~220-230V 50-60Hz, R=2/PE~220-240V 50-60Hz, U=1/N/PE~240V 50-60Hz, V=3/PE~240V 50-60Hz, W=1/N/PE~100-110V 50-60Hz

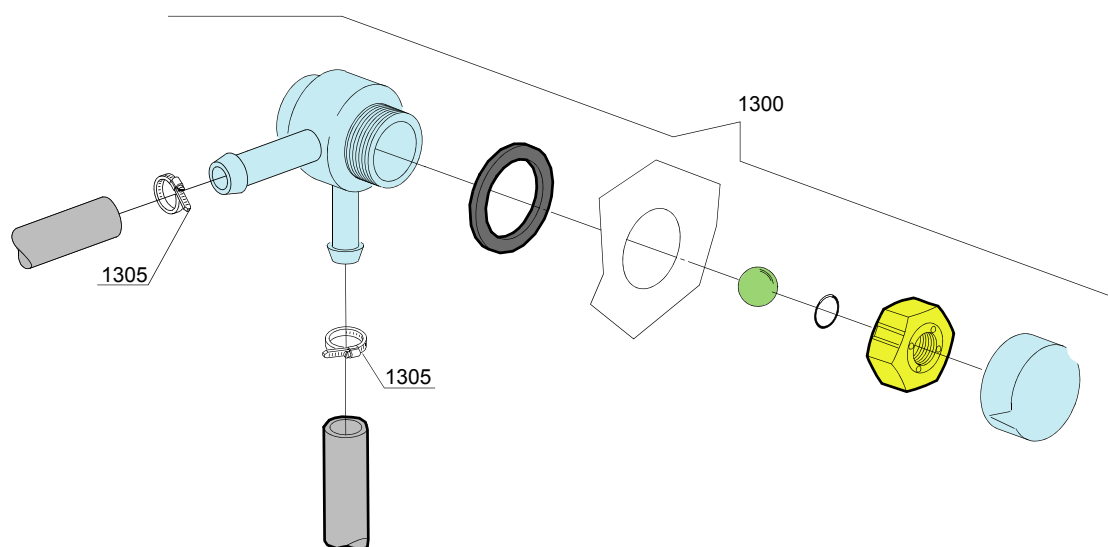

vsezip.ru

ID	P-code	SN from	SN to	Mod.	Acces.	Volt	Description
Module: DVGW							
1300	9814351		-		dvgw		DVGW assembly
1305	11807		-		dvgw		Clamp 12/22

i=INSULATED HOOD, em=ELECTROMECHANICAL SWITCHES

H63U=H63U

bt=BREAK TANK, bp=BOOSTER PUMP, dvgw=DVGW, ws=WATER SOFTNER, dd=DETERGENT DISPENSER, dp=DRAIN PUMP

A=3/N/PE~380-400V 50-60Hz, D=3/PE~200-210V 50-60Hz, F=2/PE~220-240V 50-60Hz, G=3/N/PE~415V 50-60Hz, H=3/PE~220-230V 50-60Hz, K=3/PE~380-400V 50-60Hz, L=3/PE~415V 50-60Hz, M=3/PE~440V 60Hz, P=1/N/PE~220-230V 50-60Hz, R=2/PE~220-240V 50-60Hz, U=1/N/PE~240V 50-60Hz, V=3/PE~240V 50-60Hz, W=1/N/PE~100-110V 50-60Hz

09_001_e

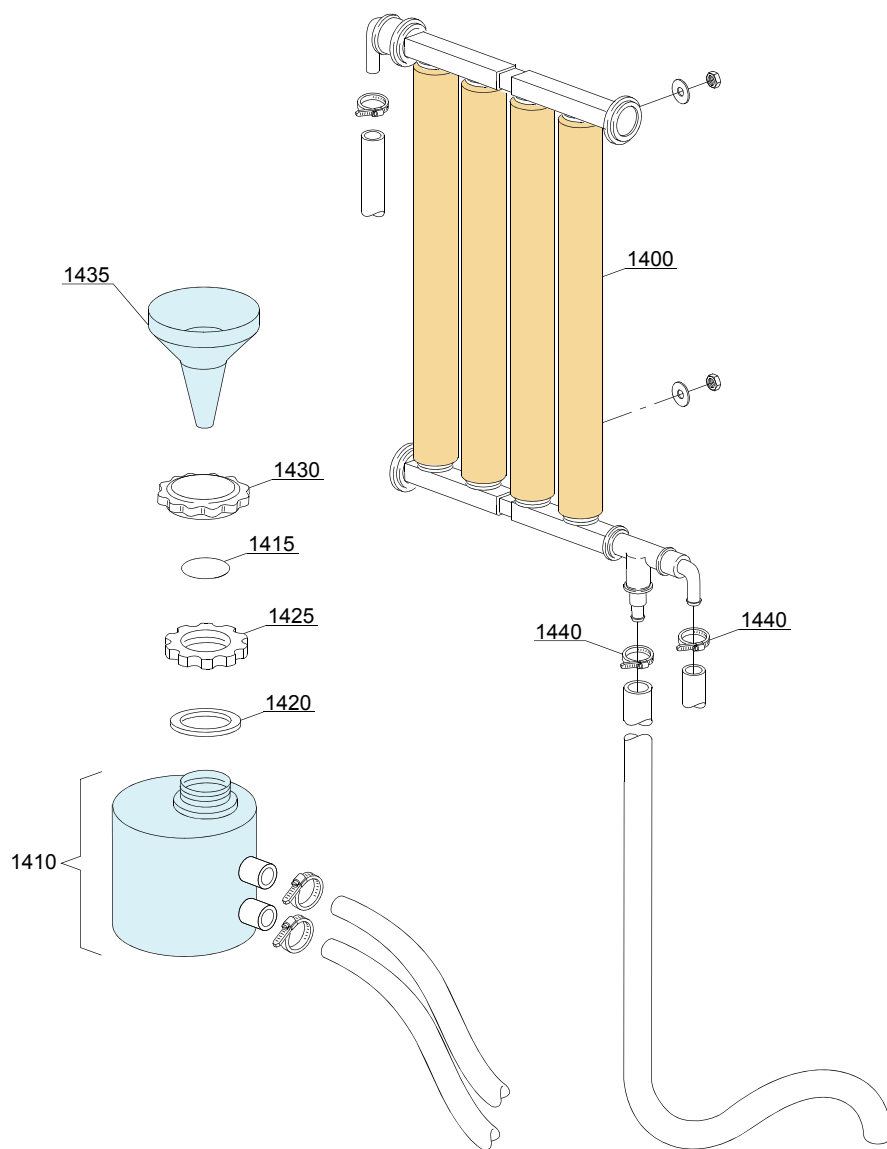

vsezip.ru

ID	P-code	SN from	SN to	Mod.	Acces.	Volt	Description
Module: Water softner group							
1400	16066		-		ws		4 elements water softner
1405	16070		-		ws		Nonreturn valve
1410	16065		-		ws		Salt container
1415	16067/A		-		ws		OR O-ring
1420	16067/B		-		ws		O-ring
1425	16067/C		-		ws		Ring nut
1430	16067/D		-		ws		Plug
1435	16082		-		ws		Funnel

i=INSULATED HOOD, em=ELECTROMECHANICAL SWITCHES

H63U=H63U

bt=BREAK TANK, bp=BOOSTER PUMP, dvgw=DVGW, ws=WATER SOFTNER, dd=DETERGENT DISPENSER, dp=DRAIN PUMP

A=3/N/PE~380-400V 50-60Hz, D=3/PE~200-210V 50-60Hz, F=2/PE~220-240V 50-60Hz, G=3/N/PE~415V 50-60Hz, H=3/PE~220-230V 50-60Hz, K=3/PE~380-400V 50-60Hz, L=3/PE~415V 50-60Hz, M=3/PE~440V 60Hz, P=1/N/PE~220-230V 50-60Hz, R=2/PE~220-240V 50-60Hz, U=1/N/PE~240V 50-60Hz, V=3/PE~240V 50-60Hz, W=1/N/PE~100-110V 50-60Hz

vsezip.ru

+7(812)987-08-81

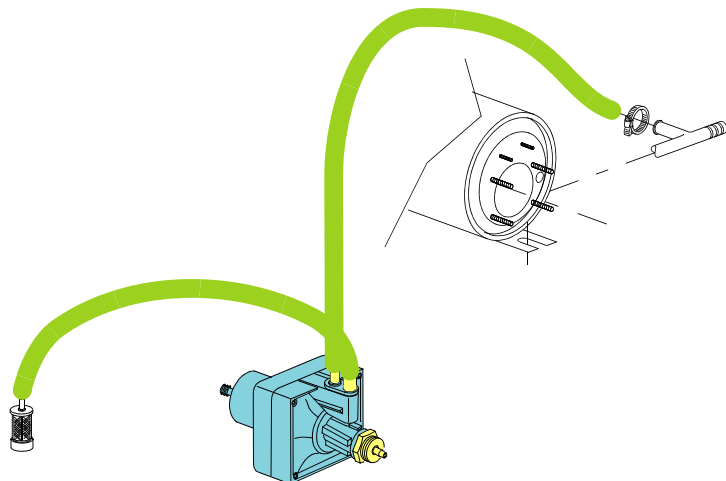
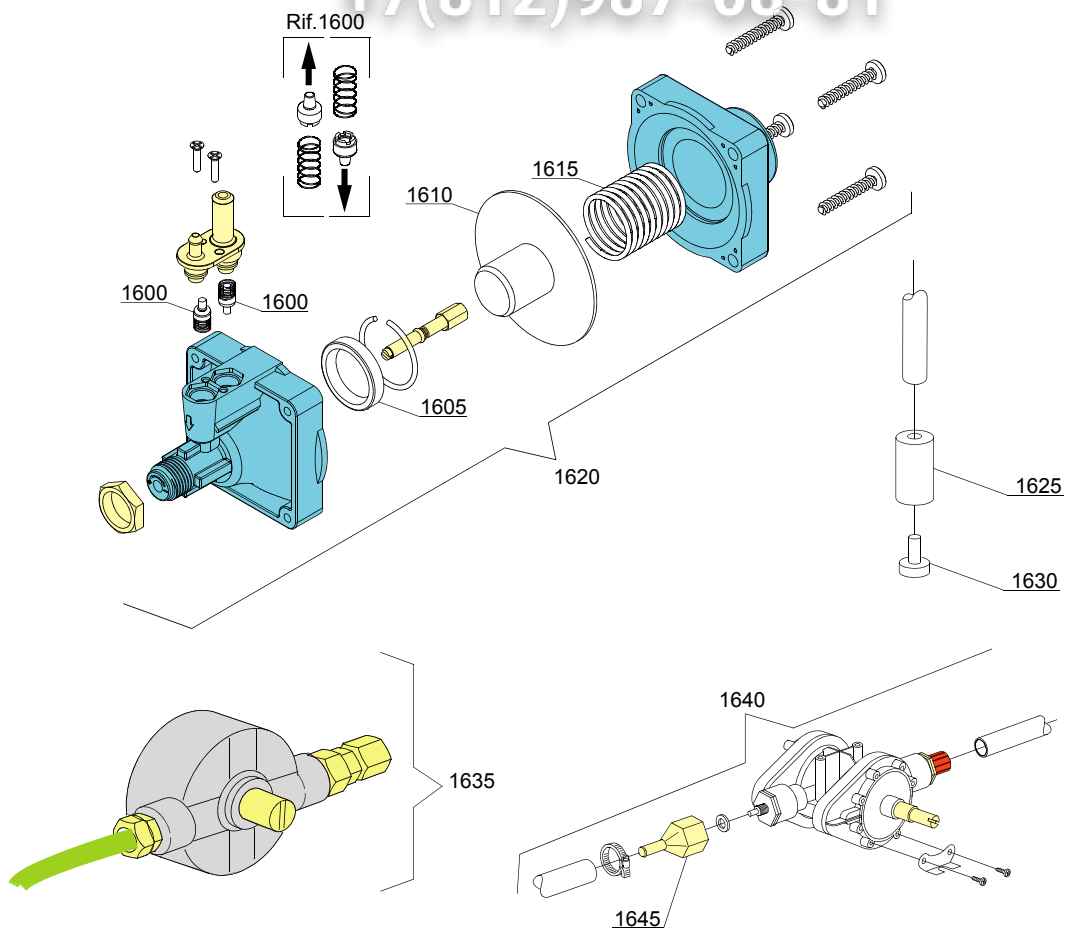

10_003_e

ID	P-code	SN from	SN to	Mod.	Acces.	Volt	Description
Module: Rinse aid dispenser group							
1600	10805		-				Tecnopro non return valve
1605	10806		-				Ø22 O-ring
1610	10807		-				Membrane
1615	10808		-				Spring
1620	10599999		-				Rinse aid dispenser
1625	12525		-				Counter-weight
1630	15058		-				Small filter
1635	10799		-				GERMAC rinse aid dispenser
1640	10798		-				LANG rinse aid dispenser
1645	10798/B		-				Brass pipe fitting

i=INSULATED HOOD, em=ELECTROMECHANICAL SWITCHES

H63U=H63U

bt=BREAK TANK, bp=BOOSTER PUMP, dvgw=DVGW, ws=WATER SOFTNER, dd=DETERGENT DISPENSER, dp=DRAIN PUMP

A=3/N/PE~380-400V 50-60Hz, D=3/PE~200-210V 50-60Hz, F=2/PE~220-240V 50-60Hz, G=3/N/PE~415V 50-60Hz, H=3/PE~220-230V 50-60Hz, K=3/PE~380-400V 50-60Hz, L=3/PE~415V 50-60Hz, M=3/PE~440V 60Hz, P=1/N/PE~220-230V 50-60Hz, R=2/PE~220-240V 50-60Hz, U=1/N/PE~240V 50-60Hz, V=3/PE~240V 50-60Hz, W=1/N/PE~100-110V 50-60Hz

vsezip.ru

+7(812)987-08-81

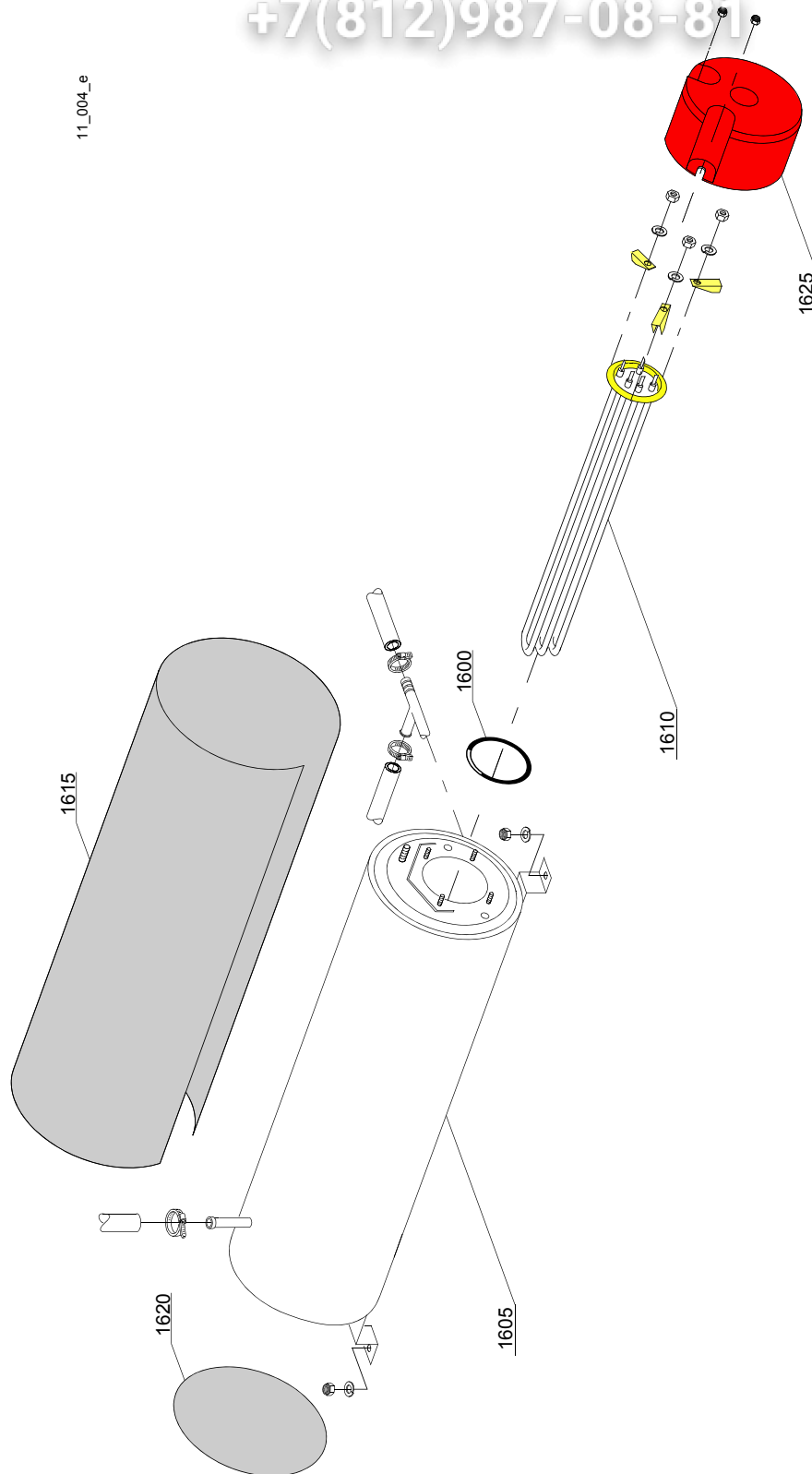

ID	P-code	SN from	SN to	Mod.	Acces.	Volt	Description
Module:Boiler group							
1600	13015		-				O-ring
1605	22002		-				Boiler
1610	30001011		-				Element 9kW
1615	30002030		-				Insulation boiler
1620	75205		-				Ø160 end piece
1625	75311		-				Heating element cover

i=INSULATED HOOD, em=ELECTROMECHANICAL SWITCHES

H63U=H63U

bt=BREAK TANK, bp=BOOSTER PUMP, dvgw=DVGW, ws=WATER SOFTNER, dd=DETERGENT DISPENSER, dp=DRAIN PUMP

A=3/N/PE~380-400V 50-60Hz, D=3/PE~200-210V 50-60Hz, F=2/PE~220-240V 50-60Hz, G=3/N/PE~415V 50-60Hz, H=3/PE~220-230V 50-60Hz, K=3/PE~380-400V 50-60Hz, L=3/PE~415V 50-60Hz, M=3/PE~440V 60Hz, P=1/N/PE~220-230V 50-60Hz, R=2/PE~220-240V 50-60Hz, U=1/N/PE~240V 50-60Hz, V=3/PE~240V 50-60Hz, W=1/N/PE~100-110V 50-60Hz

vsezip.ru

+7(812)987-08-81

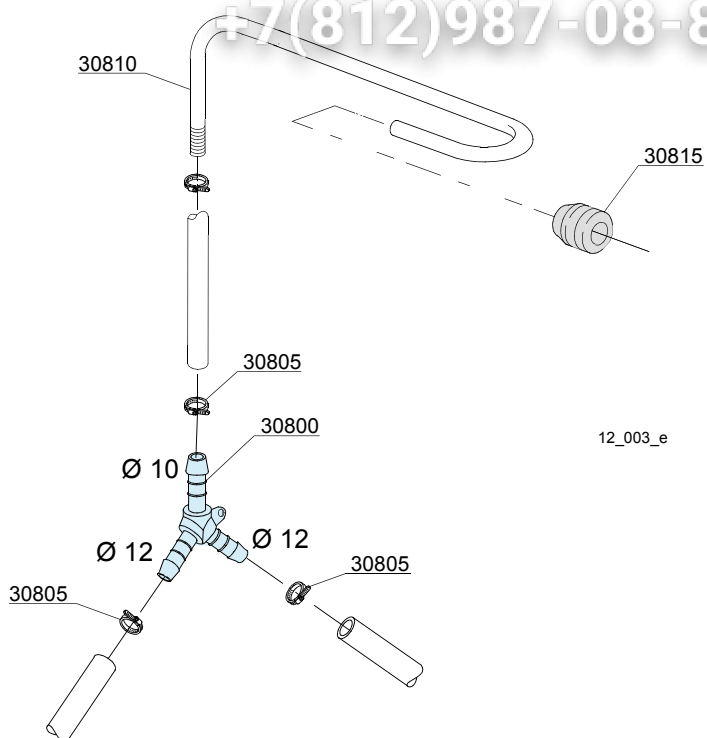

ID	P-code	SN from	SN to	Mod	Acces.	Volt	Description
Module:3 ways connection							
30800	540104		-	i			Ø10-12-12 mm plastic 3 ways connection
30805	11807		-	i			Clamp
30810	76082		-	i			Rinse pipe
30815	13304		-	i			Pipe

i=INSULATED HOOD, em=ELECTROMECHANICAL SWITCHES

H63U=H63U

bt=BREAK TANK, bp=BOOSTER PUMP, dvgw=DVGW, ws=WATER SOFTNER, dd=DETERGENT DISPENSER, dp=DRAIN PUMP

A=3/N/PE~380-400V 50-60Hz, D=3/PE~200-210V 50-60Hz, F=2/PE~220-240V 50-60Hz, G=3/N/PE~415V 50-60Hz, H=3/PE~220-230V 50-60Hz, K=3/PE~380-400V 50-60Hz, L=3/PE~415V 50-60Hz, M=3/PE~440V 60Hz, P=1/N/PE~220-230V 50-60Hz, R=2/PE~220-240V 50-60Hz, U=1/N/PE~240V 50-60Hz, V=3/PE~240V 50-60Hz, W=1/N/PE~100-110V 50-60Hz

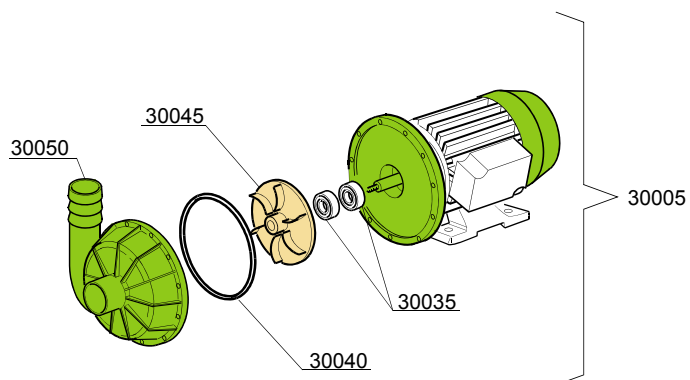
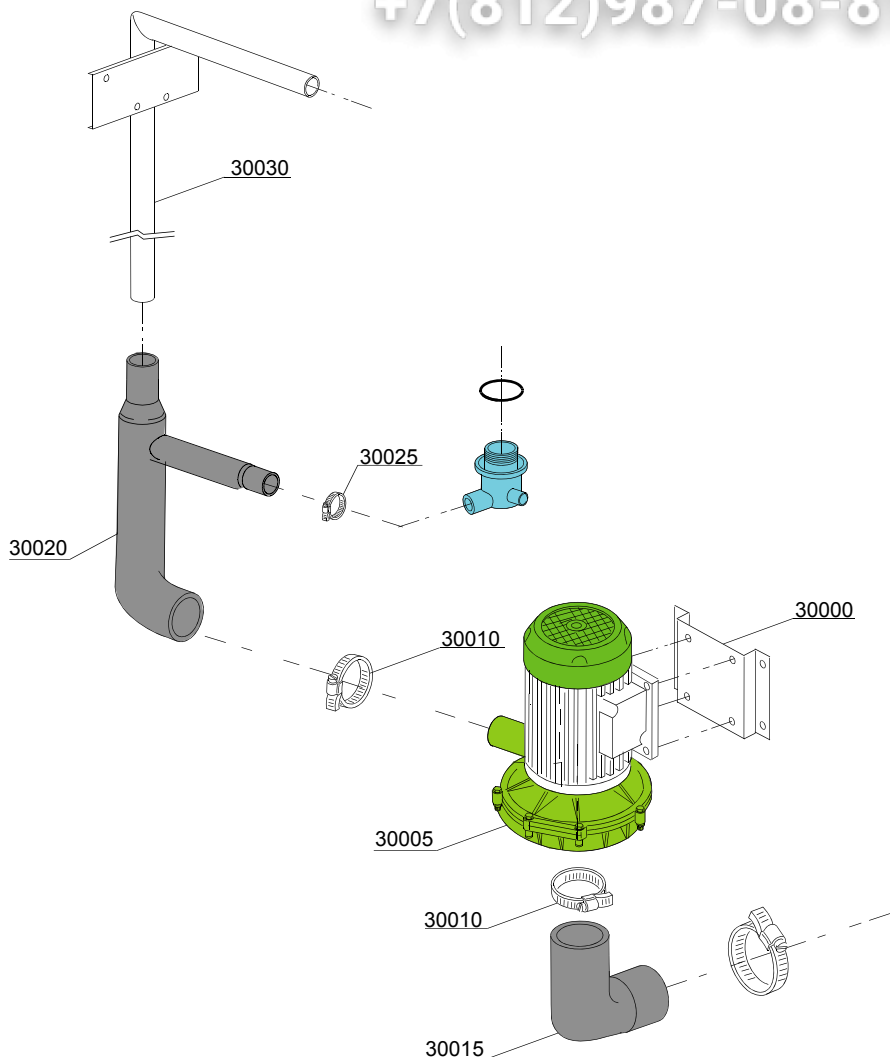

ID	P-code	SN from	SN to	Mod.	Acces.	Volt	Description
Module: Wash pump group							
30000	11600623		-	em			Pump base
30005	22037		-	em			2Hp pump 230/380/415 3Fh 50Hz
30010	11824		-	em			50/70 Clamp
30015	11600100		-	em			Suction pipe coupling
30020	11600101		-	em			Pressure rubber hose
30025	11809		-	em			30/45 Clamp
30030	11600103		-	em			Wash ramp
30035	15080		-	em			Rotating seals
30040	10200290		-	em			OR 1225 O-ring
30045	22045		-	em			Pump rotor (pump 2Hp)
30050	10200222		-	em			Scroll

i=INSULATED HOOD, em=ELECTROMECHANICAL SWITCHES

H63U=H63U

bt=BREAK TANK, bp=BOOSTER PUMP, dvgw=DVGW, ws=WATER SOFTNER, dd=DETERGENT DISPENSER, dp=DRAIN PUMP

A=3/N/PE~380-400V 50-60Hz, D=3/PE~200-210V 50-60Hz, F=2/PE~220-240V 50-60Hz, G=3/N/PE~415V 50-60Hz, H=3/PE~220-230V 50-60Hz, K=3/PE~380-400V 50-60Hz, L=3/PE~415V 50-60Hz, M=3/PE~440V 60Hz, P=1/N/PE~220-230V 50-60Hz, R=2/PE~220-240V 50-60Hz, U=1/N/PE~240V 50-60Hz, V=3/PE~240V 50-60Hz, W=1/N/PE~100-110V 50-60Hz

vsezip.ru

+7(812)987-08-81

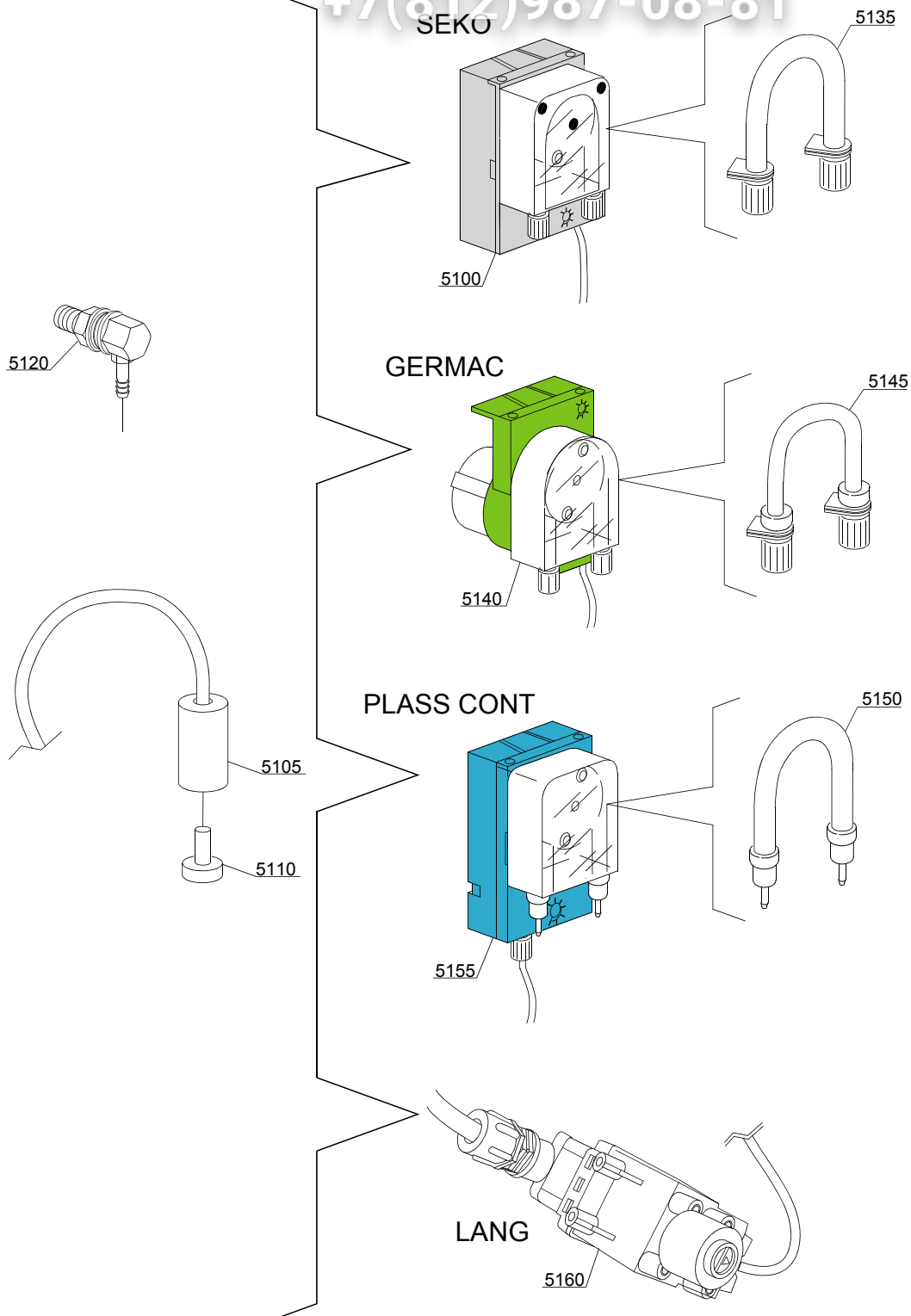

14_004_e

vsezip.ru

ID	P-code	SN from	SN to	Mod	Acces	Volt	Description
Module:Dosing detergent group							
5100	15985		-	i	dd		Seko detergent pump
5105	12525		-	i	dd		Counter-weight
5110	15058		-	i	dd		Small filter
5120	15123		-	i	dd		Complet Steel injector
5125	15159		-	i	dd		OR O-ring
5130	10200205		-	i	dd		M12x1 stainless steel nut
5135	15185		-	i	dd		Seko thermoplastic pipe Ø 10
5140	15985		-	i	dd		Germac detergent pump
5145	15108/E		-	i	dd		Germac thermoplastic pipe Ø 8
5150	15985/A		-	i	dd		Ø 10 PLAS CONT thermoplastic pipe
5155	15985		-	i	dd		PLAS CONT detergent pump
5160	15108/L		-	i	dd		LANG detergent pump

i=INSULATED HOOD, em=ELECTROMECHANICAL SWITCHES

H63U=H63U

bt=BREAK TANK, bp=BOOSTER PUMP, dvgw=DVGW, ws=WATER SOFTNER, dd=DETERGENT DISPENSER, dp=DRAIN PUMP

A=3/N/PE~380-400V 50-60Hz, D=3/PE~200-210V 50-60Hz, F=2/PE~220-240V 50-60Hz, G=3/N/PE~415V 50-60Hz, H=3/PE~220-230V 50-60Hz, K=3/PE~380-400V 50-60Hz, L=3/PE~415V 50-60Hz, M=3/PE~440V 60Hz, P=1/N/PE~220-230V 50-60Hz, R=2/PE~220-240V 50-60Hz, U=1/N/PE~240V 50-60Hz, V=3/PE~240V 50-60Hz, W=1/N/PE~100-110V 50-60Hz

15_005_e

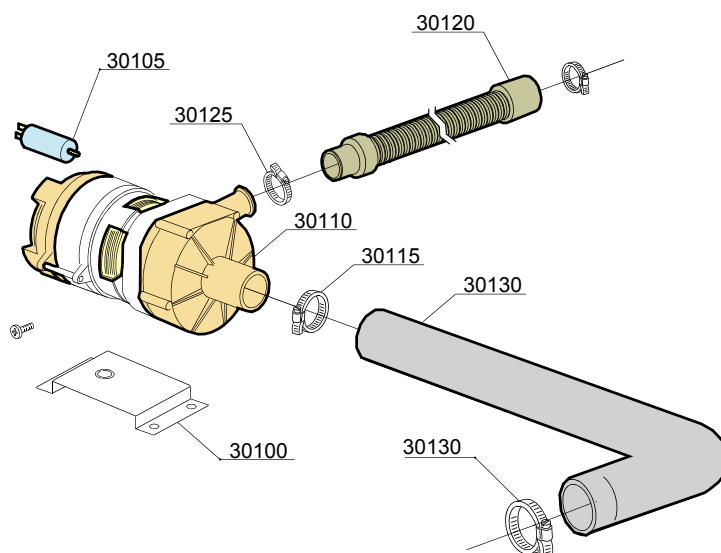

ID	P-code	SN from	SN to	Mod	Acces.	Volt	Description
Module: Drain pump group							
30100	440122		-		dp		Pump support
30105	10702		-		dp		5 uF condenser
30110	10501/A		-		dp		Drain pump (extra equipment)
30115	11806		-		dp		25/40 clamp
30120	10727		-		dp		Drain pipe
30125	11809		-		dp		Clamp
30130	18788		-		dp		Drain rubber elbow

i=INSULATED HOOD, em=ELECTROMECHANICAL SWITCHES

H63U=H63U

bt=BREAK TANK, bp=BOOSTER PUMP, dvgw=DVGW, ws=WATER SOFTNER, dd=DETERGENT DISPENSER, dp=DRAIN PUMP

A=3/N/PE~380-400V 50-60Hz, D=3/PE~200-210V 50-60Hz, F=2/PE~220-240V 50-60Hz, G=3/N/PE~415V 50-60Hz, H=3/PE~220-230V 50-60Hz, K=3/PE~380-400V 50-60Hz, L=3/PE~415V 50-60Hz, M=3/PE~440V 60Hz, P=1/N/PE~220-230V 50-60Hz, R=2/PE~220-240V 50-60Hz, U=1/N/PE~240V 50-60Hz, V=3/PE~240V 50-60Hz, W=1/N/PE~100-110V 50-60Hz

vsezip.ru

+7(812)987-08-81

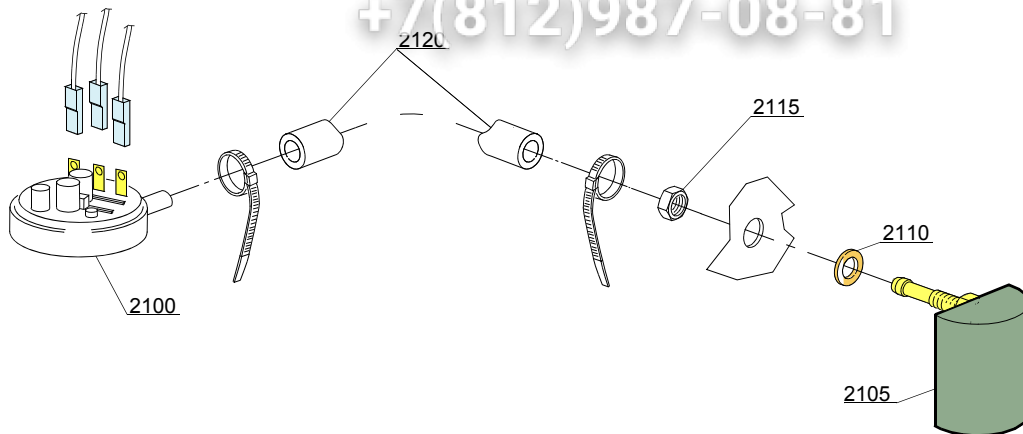

16_001_e

ID	P-code	SN from	SN to	Mod	Acces.	Volt	Description
Module: Pressure switch group with air trap							
2100	88110		-				Pressure switch PR
2105	135911/B		-				Air trap
2110	13301		-				Gasket
2115	11702		-				Nut
2120	14508		-				4,5x9 EPDM rubber hose (minimum 2-mt)

i=INSULATED HOOD, em=ELECTROMECHANICAL SWITCHES

H63U=H63U

bt=BREAK TANK, bp=BOOSTER PUMP, dvgw=DVGW, ws=WATER SOFTNER, dd=DETERGENT DISPENSER, dp=DRAIN PUMP

A=3/N/PE~380-400V 50-60Hz, D=3/PE~200-210V 50-60Hz, F=2/PE~220-240V 50-60Hz, G=3/N/PE~415V 50-60Hz, H=3/PE~220-230V 50-60Hz, K=3/PE~380-400V 50-60Hz, L=3/PE~415V 50-60Hz, M=3/PE~440V 60Hz, P=1/N/PE~220-230V 50-60Hz, R=2/PE~220-240V 50-60Hz, U=1/N/PE~240V 50-60Hz, V=3/PE~240V 50-60Hz, W=1/N/PE~100-110V 50-60Hz

vsezip.ru

+7(812)987-08-81

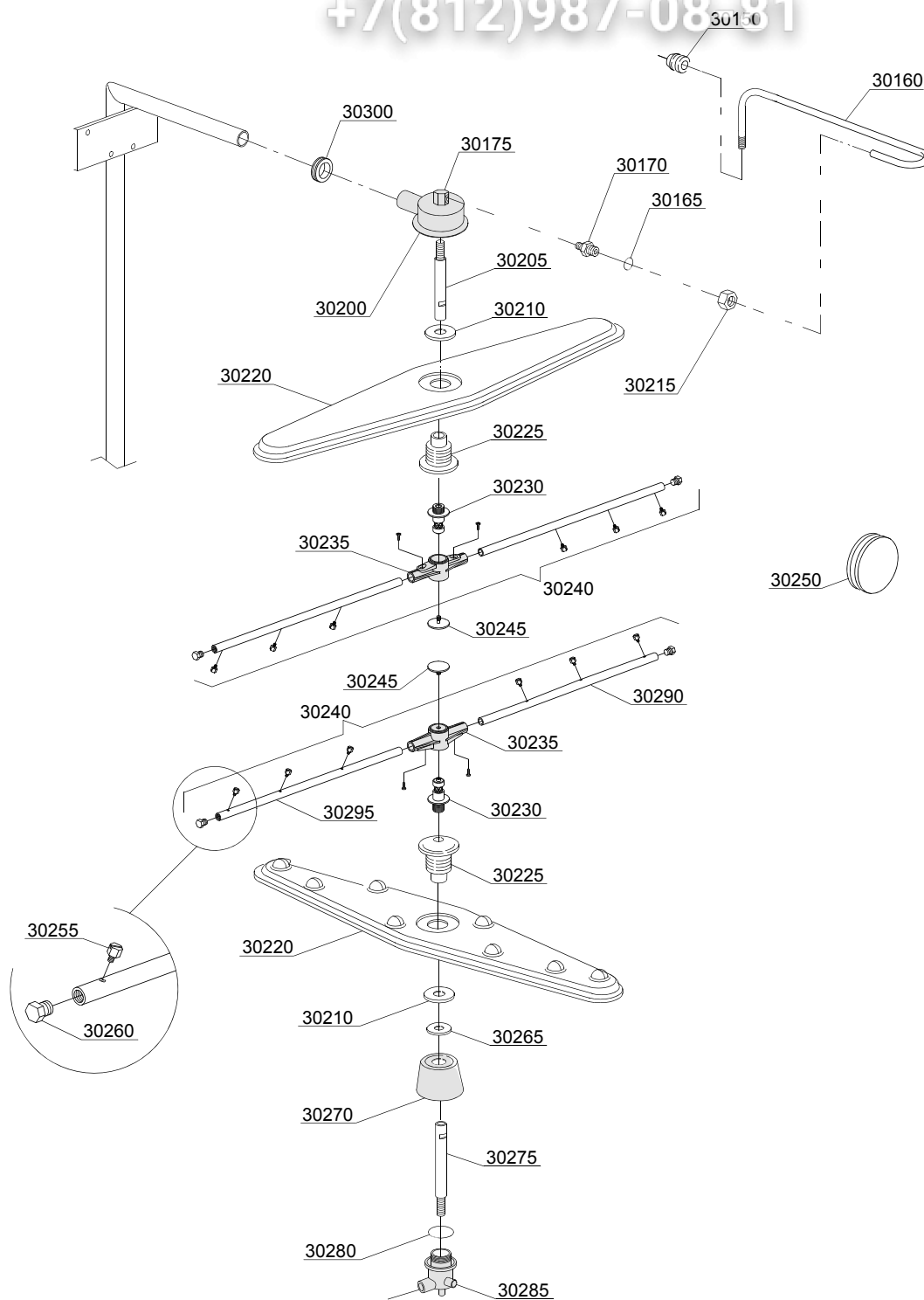

17_125_e

ID	P-code	SN from	SN to	Mod.	Acces	Volt	Description
Module:Turret group with rotating arms							
30150	13304	4025782	-	em			Pipe
30160	76082	4025782	-	em			Pipe gasket
30165	13003		-	em			OR 112 NBR O-ring
30170	12006		-	em			Coupling
30175	75319		-	em			Elbow coupling
30200	78001		-	em			Distributor upper
30205	75322		-	em			Shaft, upper
30210	75317		-	em			Nut
30215	12006/A		-	em			Ø10 pipe fitting 3/8x3,5 nut 19 hexagonal
30220	10600900		-	em			Wash arm
30225	75320		-	em			Holder
30230	10651		-	em			Rinse axle
30235	10650		-	em			Rinse arm
30240	75918		-	em			Rinse arm, compl.
30245	10652		-	em			Rinse arm screw
30250	13316/A		-	em			DVGW hole O-ring
30255	560018		-	em			Nozzle
30260	560017		-	em			Plug
30265	11600033		-	em			Ring
30270	11600007		4025334	em			Support
30270	11600035	4025335	-	em			Lower wash arm support
30275	11600021		-	em			Shaft, lower
30280	13015		-	em			O-ring
30285	500621		-	em			Distributor lower
30290	10657		-	em			Right rinse arm - stainless steel nozzle
30295	10658		-	em			Left rinse arm - stainless steel nozzle
30300	76081	4025782	-	em			Pipe-pass O-ring 51x34x14

i=INSULATED HOOD, em=ELECTROMECHANICAL SWITCHES

H63U=H63U

bt=BREAK TANK, bp=BOOSTER PUMP, dvgw=DVGW, ws=WATER SOFTNER, dd=DETERGENT DISPENSER, dp=DRAIN PUMP

A=3/N/PE~380-400V 50-60Hz, D=3/PE~200-210V 50-60Hz, F=2/PE~220-240V 50-60Hz, G=3/N/PE~415V 50-60Hz, H=3/PE~220-230V 50-60Hz, K=3/PE~380-400V 50-60Hz, L=3/PE~415V 50-60Hz, M=3/PE~440V 60Hz, P=1/N/PE~220-230V 50-60Hz, R=2/PE~220-240V 50-60Hz, U=1/N/PE~240V 50-60Hz, V=3/PE~240V 50-60Hz, W=1/N/PE~100-110V 50-60Hz

vsezip.ru

+7(812)987-08-81

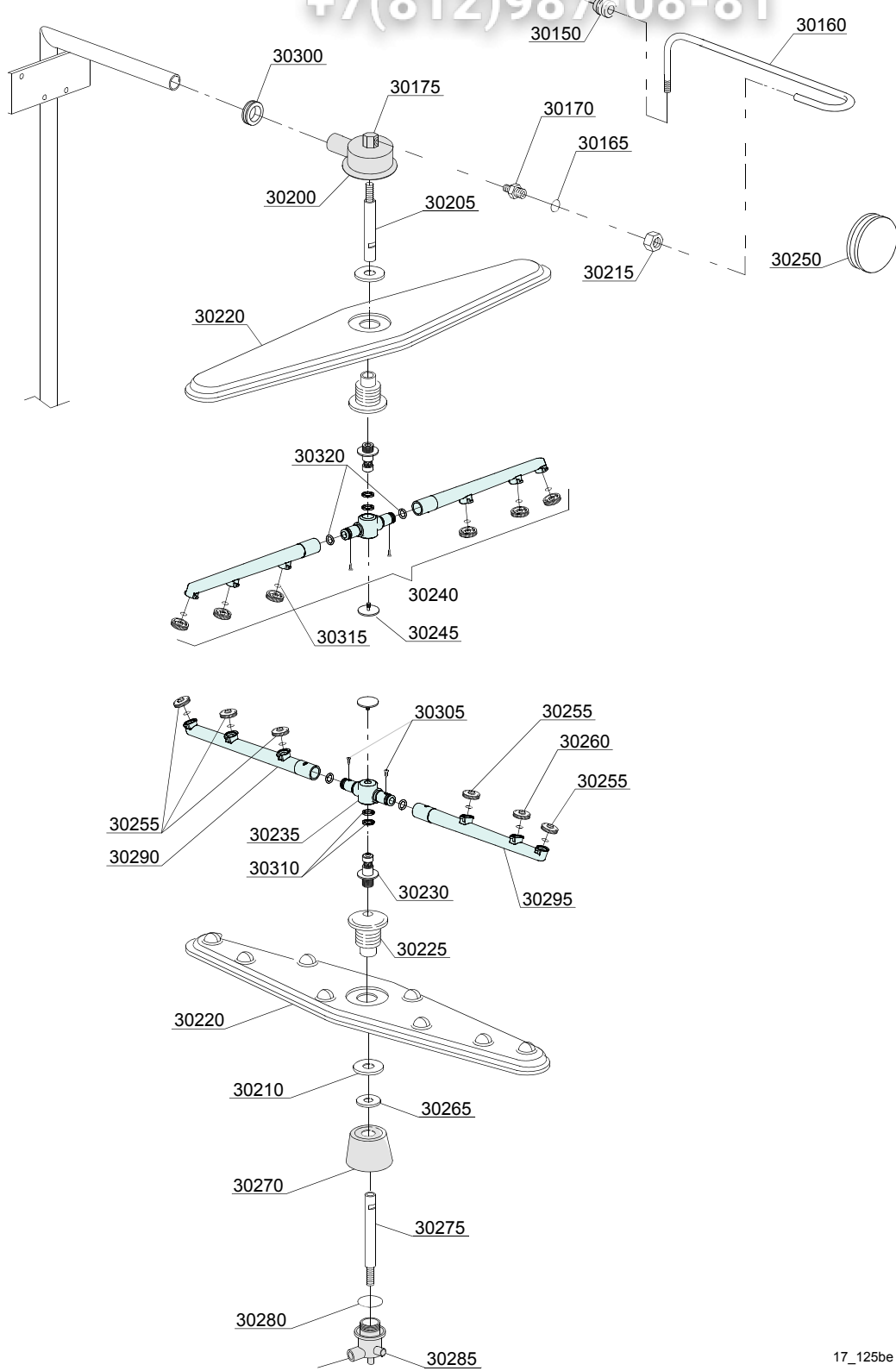

17_125be

vsezip.ru

ID	P-code	SN from	SN to	Mod	Acces.	Volt	Description
Module:Turret group with rotating arms							
30150	13304		-	em			Pipe
30160	76082		-	em			Pipe gasket
30165	13003		-	em			OR 112 NBR O-ring
30170	12006		-	em			Coupling
30175	75319		-	em			Elbow coupling
30200	78001		-	em			Distributor upper
30205	75322		-	em			Shaft, upper
30210	75317		-	em			Nut
30215	12006/A		-	em			Ø10 pipe fitting 3/8x3,5 nut 19 hexagonal
30220	10600900		-	em			Wash arm
30225	75320		-	em			Holder
30230	10651		-	em			Rinse axle
30235	75920/A		-	em			Rinse arm
30240	75920		-	em			Rinse arm complete
30245	10652		-	em			Rinse arm screw
30255	10371		-	em			Open rinse nozzle
30260	10372		-	em			Closed rinse nozzle
30265	11600033		-	em			Ring
30270	11600035		-	em			Lower wash arm support
30275	11600021		-	em			Shaft, lower
30280	13015		-	em			O-ring
30285	500621		-	em			Distributor lower
30290	75920/D		-	em			Right rinse arm
30295	75920/S		-	em			Left rinse arm
30300	76081		-	em			Pipe-pass O-ring 51x34x14
30305	11004		-	em			4x10 TCB Ø8 spax toothed screw
30310	75920/B		-	em			O ring for hub (rinse arm)
30315	13002		-	em			OR R6 NBR O-ring (minimum 10 pieces)

i=INSULATED HOOD, em=ELECTROMECHANICAL SWITCHES

H63U=H63U

bt=BREAK TANK, bp=BOOSTER PUMP, dvgw=DVGW, ws=WATER SOFTNER, dd=DETERGENT DISPENSER, dp=DRAIN PUMP

A=3/N/PE~380-400V 50-60Hz, D=3/PE~200-210V 50-60Hz, F=2/PE~220-240V 50-60Hz, G=3/N/PE~415V 50-60Hz, H=3/PE~220-230V 50-60Hz, K=3/PE~380-400V 50-60Hz, L=3/PE~415V 50-60Hz, M=3/PE~440V 60Hz, P=1/N/PE~220-230V 50-60Hz, R=2/PE~220-240V 50-60Hz, U=1/N/PE~240V 50-60Hz, V=3/PE~240V 50-60Hz, W=1/N/PE~100-110V 50-60Hz

vsezip.ru

+7(812)987-08-81

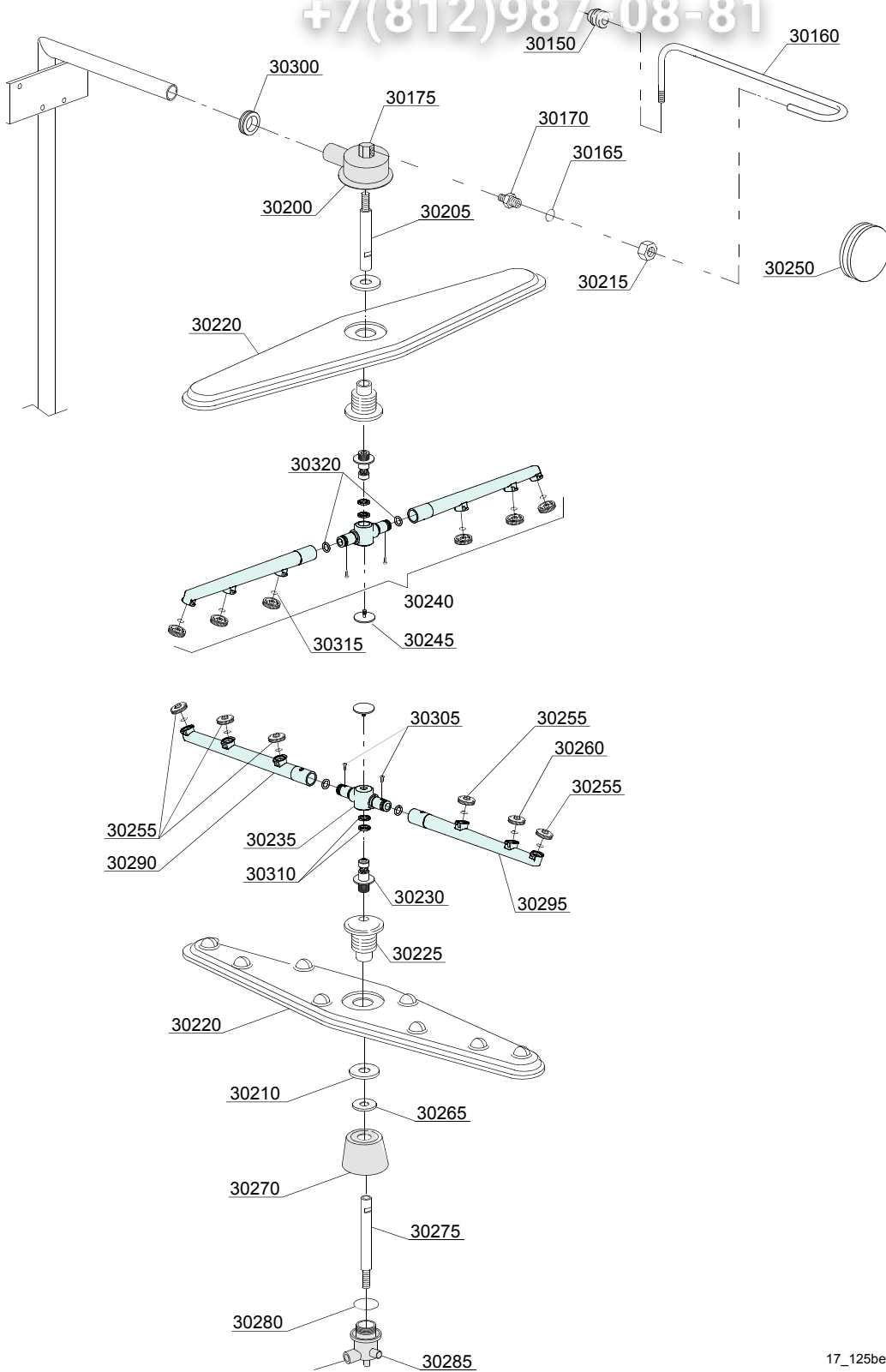

17_125be

vsezip.ru

ID	P-code	SN from	SN to	Mod.	Acces	Volt	Description
Module:Turret group with rotating arms							
30320	13002		-	em			OR R6 NBR O-ring (minimum 10 pieces)

i=INSULATED HOOD, em=ELECTROMECHANICAL SWITCHES

H63U=H63U

bt=BREAK TANK, bp=BOOSTER PUMP, dvgw=DVGW, ws=WATER SOFTNER, dd=DETERGENT DISPENSER, dp=DRAIN PUMP

A=3/N/PE~380-400V 50-60Hz, D=3/PE~200-210V 50-60Hz, F=2/PE~220-240V 50-60Hz, G=3/N/PE~415V 50-60Hz, H=3/PE~220-230V 50-60Hz, K=3/PE~380-400V 50-60Hz, L=3/PE~415V 50-60Hz, M=3/PE~440V 60Hz, P=1/N/PE~220-230V 50-60Hz, R=2/PE~220-240V 50-60Hz, U=1/N/PE~240V 50-60Hz, V=3/PE~240V 50-60Hz, W=1/N/PE~100-110V 50-60Hz