

Зип Общепит

vsezip.ru

+7(812)987-08-81

TWIN STAR

ELECTRONICAL SWITCHES
LOWER AND UPPER WASHER

TYPE: 127EU

Spare parts Manual



Parti di ricambio

Spare Parts

Catalogues pièces

Piezas de recambis

Ersatzteile

INFORMAZIONI GENERALI

Questo catalogo serve per richiedere con esattezza le parti di ricambio

Nelle ordinazioni indicare:

1) il numero dei codici dei particolari seguito dalla descrizione e la quantità desiderata;

2) Il codice alfa-numeric presente nella seconda colonna della tabella ;

I disegni delle parti di ricambio sono solo indicativi e non rappresentano il pezzo in oggetto.

I dati contenuti in questo catalogo sono indicativi e possono essere soggetti a modifiche senza impegno di preavviso.

ALLGEMEINE INFORMATIONEN

Dieser Ersatzteilkatalog dient zur genauen Angabe der Teile bei Ersatzteilbestellungen.

Bei Ersatzbestellung ist folgendes anzugeben:

1) Die Bestellnummer der Ersatzteile mit der entsprechenden Beschreibung genaue Menge;

2) Der alpha-numerischer Code auf der zweiten Reihe in dein Sculd;

Die Zeichnungen der Ersatzteile sind nur als Hinweise gedacht und stellen nicht das betroffene Teil dar.

Bei den im Katalog angeführten Daten handelt es sich um Anhaltsdaten, die jederzeit, ohne Vorankündigung, geändert werden können.

GENERAL INFORMATION

The present spare parts order exactly the right spare parts

When ordering specify:

1) the part's code number followed by its description and quantity needed;

2) The alpha-numeric code is in the second column in the chart;

Spare parts drawings are general and do not represent the part.

The contents of this catalogue are general and can undergo changes without prior notice.

INFORMACIONES GENERALES

El presente catálogo sirve para pedir con exactitud las partes de repuesto

En los pedidos se debe indicar:

1) el número de código de la parte y a continuación la descripción cantidad deseada;

2) El código alfanumerico presente en la segnada columna de la tabla;

Los diseños de las partes de recambio son solo indicativos y no representan la pieza en cuestión.

Los datos contenidos en el presente catálogo son indicativos y pueden modificarse sin aviso previo.

INFORMATIONS GENERALES

Ce catalogue permet de commander correctement les pièces détachées

Les commandes doivent être passées en indiquant:

1) le numero de code des pièces détachées suivi de leur description quantité désirée;

2) le code alphanumérique dans la deuxième colonne du tableau;

Les plans des pièces détachées sont fournis seulement à titre indicatif et ne représentent pas la pièce concernée.

Les données de ce catalogue sont citées seulement à titre indicatif et peuvent être l'objet de modifications sans avis préalable.

ESEMPIO
EXAMPLE
EXEMPLE
BEISPIEL

Rif.	Codici
MODULE:Particolari	
10505	540903
10510	540908
10515	15065/A
10520	540086
10525	540028



Note

Tutte le informazioni riportate si intendono aggiornate alla data di stampa. Il Produttore si riserva il diritto di apportare qualsiasi modifica richiesta dallo sviluppo evolutivo dei suddetti prodotti.

Per la sicurezza ,la garanzia, l'affidabilità ed il valore della lavastoviglie usa solo ricambi originali. **Per alcuni codici, sono richieste quantità minime d'ordine.**



Attenzione

Questo libretto è parte integrante della lavastoviglie e, in caso di passaggio di proprietà, deve essere consegnato al nuovo acquirente.



Remarque

Toutes les informations contenues dans ce manuel s'entendent mises à jour à la date d'impression. En raison du développement constant de ses produits, usine se réserve le droit d'apporter à tout instant les modifications qu'elle jugera utiles.

Pour la sécurité, la garantie, la fiabilité et la valeur de votre lavevaisselles n'utilisez que des pièces de rechange d'origine. **Pour quelque référence on demande un minimum de pièces par commande**



Attention

Ce manuel doit être considéré comme partie intégrante de la la lavevaisselles, en cas de transfert de propriété, doit toujours être remis au nouveau propriétaire.



Note

The information contained herein is valid at the time of going to print. The Company reserves the right to make any changes required by the future development of the above-mentioned products.

For your safety, as well as to preserve the warranty reliability and worth of your dishwashers , use original spare parts only. **For some codes a minimum quantity for order is required.**



Warning

This manual forms an integral part of the dishwashers and - if a transfer of title occurs - must always be handed over to the new owner.



Hinweis

Die Der Hersteller behält sich das Recht vor, jegliche, durch eine Weiterentwicklung der genannten Produkte bedingte Änderungen vornehmen zu können.

Verwenden Sie für Ihre Sicherheit, die Garantie, die Zuverlässigkeit und den Wert Ihrer machine originale Ersatzteile. **Für bestimmte Code nummer werden mindesten bestellungen verlangt.**



Achtung

Diese Betriebsanleitung ist Bestandteile des machine und muss bei seinem Weiterverkauf dem neuen Besitzer ausgehändigt werden.



Parti di ricambio

Spare Parts

Catalogues pièces

Piezas de recambis

Ersatzteile

+7(812)987-08-81

vsezip.ru

Зип Общепит

Code DW 009M.0001 **CL/Part**

Model DESCRIPTION

S/N DW A 1000001 **Type**

400V 3N 50HZ 8A
3500W 500W

IPX3  16A

Pressione Dinamica alimentazione idrica **200-500 kPa**

Pression dynamique arrivée d'eau

Dynamic pressure water supply

Dynamischer Druck asserreinlauf

Pressione dinamica vapore saturo

Pression dynamique vapeur satueèè

Dymanischer Druck gesattigter Dampf

Pression Dinamica Vapor Saturado

TECHICAL SPECIFICATION



MADE IN ITALY

Temperatura massima acqua in ingresso **60°C**

Temperature max eau a l'entre

Maximale Temperatur Wasseranschlü

Maximum Water temperature in-feeding

Model 

S/N 

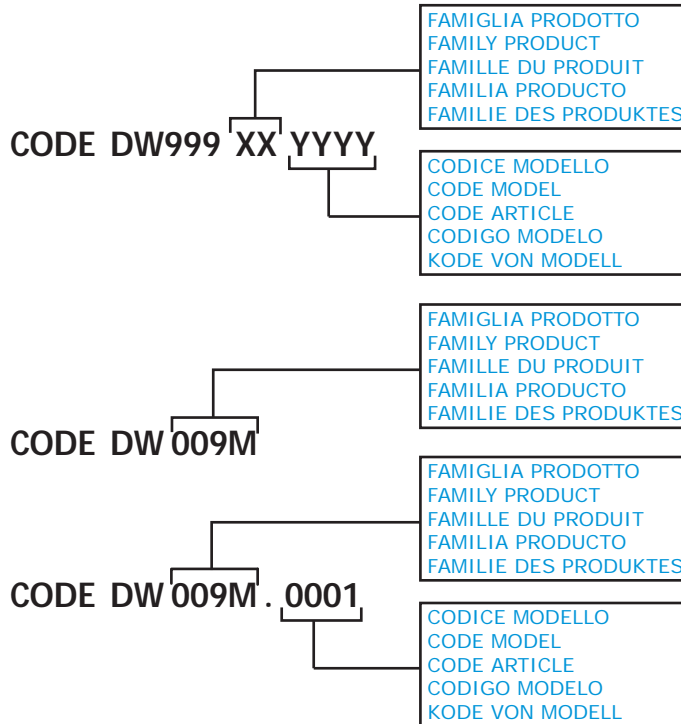

POSIZIONE MATRICOLA / LOCATION OF SERIAL NUMBER / EMBLACEMENT DU NUMERO DE SERIE

Зип Общепит

MATRICOLA
SERIAL NUMBER
NUMERO DE SERIE

vsezip.ru

+7(812)987-08-81

MATRICOLA
SERIAL NUMBER
NUMERO DE SERIE

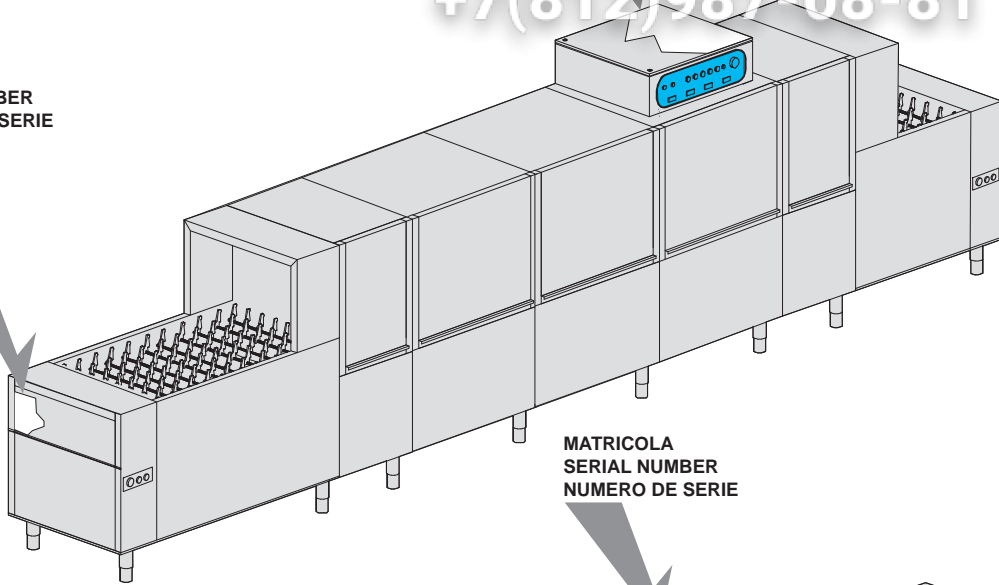

MATRICOLA
SERIAL NUMBER
NUMERO DE SERIE

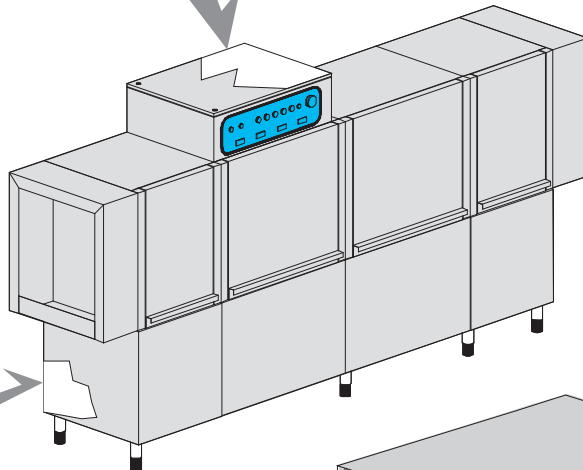

MATRICOLA
SERIAL NUMBER
NUMERO DE SERIE

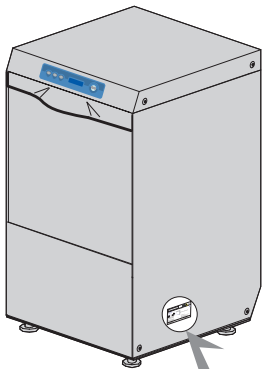

MATRICOLA
SERIAL NUMBER
NUMERO DE SERIE

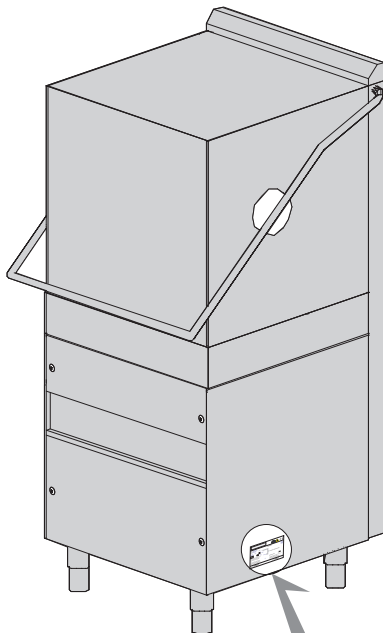

MATRICOLA
SERIAL NUMBER
NUMERO DE SERIE



MATRICOLA
SERIAL NUMBER
NUMERO DE SERIE

1. Spare parts

General body parts.....	9
General body parts.....	11
General body parts.....	13
General body parts.....	15
Closing panelig.....	17
Handle	19
Control panel and switches.....	21
Electric control components.....	23
Electric control components.....	25
Water softner group.....	27
Water softner group.....	29
Water softner group.....	31
Condensing.....	33
Condensing.....	35
DVGW valve	37
Rinse aid dispenser group.....	39

Wash pump group..... 41

Wash pump group..... 43

Drain pump group..... 45

Turret group with rotating arms 47

1.1 Voltage codes

Volt	Voltage code
A	3/N/PE~380-400V 50-60Hz
D	3/PE~200-210V 50-60Hz
F	2/PE~220-240V 50-60Hz
G	3/N/PE~415V 50-60Hz
H	3/PE~220-230V 50-60Hz
K	3/PE~380-400V 50-60Hz
L	3/PE~415V 50-60Hz
M	3/PE~440V 60Hz
P	1/N/PE~220-230V 50-60Hz
R	2/PE~220-240V 50-60Hz
U	1/N/PE~240V 50-60Hz
V	3/PE~240V 50-60Hz
W	1/N/PE~100-110V 50-60Hz

1.2 Product codes

Product code	Full name
Model codes	
e	ELECTRONICAL SWITCHES
uw	LOWER AND UPPER WASHER
Type codes	
127EU	127EU
Accessory codes	

vsezip.ru

+7(812)987-08-81

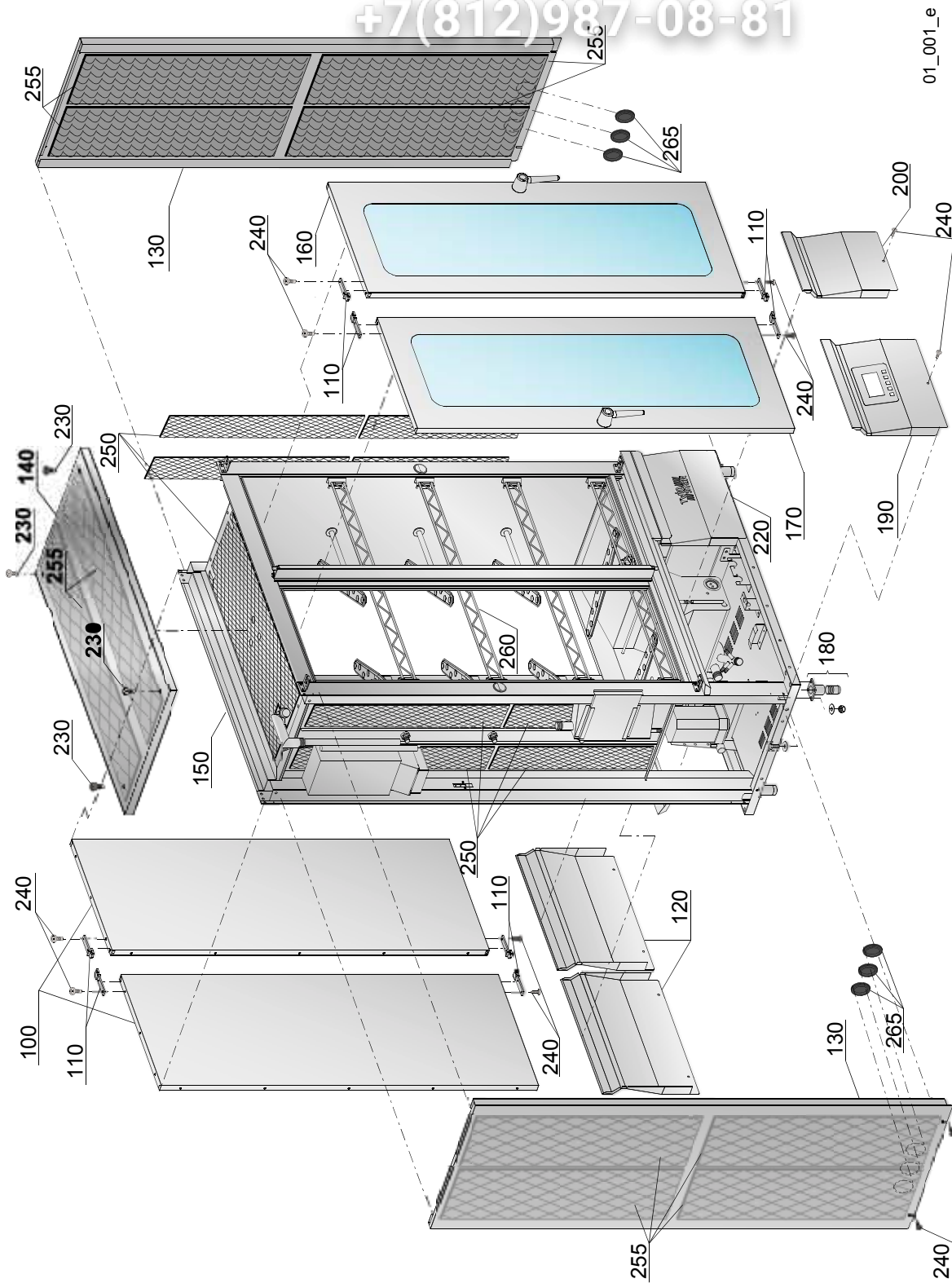

01_001_e

vsezip.ru

ID	P-code	SN from	SN to	Mod	Acces	Volt	Description
Module:General body parts							
100	590058		-				Right/Left rear cover
110	590015		-				Door hinge
120	590060		-				Panel cover
130	590033		-				External side panel
140	590049		-				Cover
150	590000		-				Machine structure
160	590001		-				Right door
170	590002		-				Left door
180	590029		-				Foot
190	590030		-				Key board panel
200	590032		-				Center panel
220	590091		-				Panel tanks-drawer
230	590098		-				S/S screw M6x70
240	11168		-				S/S screw M6X12 TCB large 13x3
250	590720		-				Side panels insulating kit
255	590127		-				Side panels and cover insultaing kit
260	590070		-				Rack rails
265	13317		-				Ø 40 lead through rubber (minimum 2 pieces)

e=ELECTRONICAL SWITCHES, uw=LOWER AND UPPER WASHER

127EU=127EU

A=3/N/PE~380-400V 50-60Hz, D=3/PE~200-210V 50-60Hz, F=2/PE~220-240V 50-60Hz, G=3/N/PE~415V 50-60Hz, H=3/PE~220-230V 50-60Hz, K=3/PE~380-400V 50-60Hz, L=3/PE~415V 50-60Hz, M=3/PE~440V 60Hz, P=1/N/PE~220-230V 50-60Hz, R=2/PE~220-240V 50-60Hz, U=1/N/PE~240V 50-60Hz, V=3/PE~240V 50-60Hz, W=1/N/PE~100-110V 50-60Hz

vsezip.ru

+7(812)987-08-81

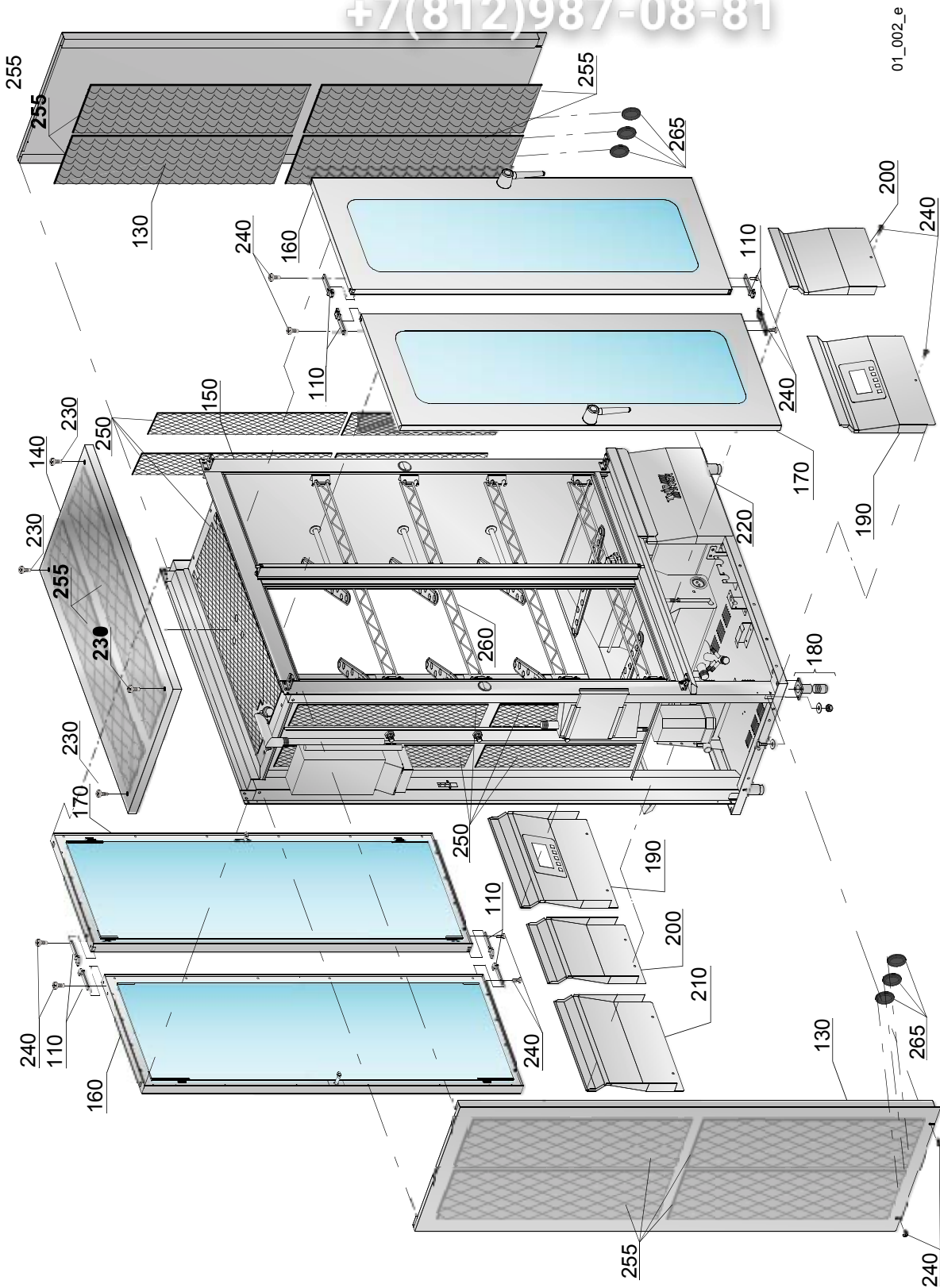

ID	P-code	SN from	SN to	Mod.	Acces.	Volt	Description
Module:General body parts							
110	590015		-				Door hinge
130	590033		-				External side panel
140	590049		-				Cover
150	590000		-				Machine structure
160	590001		-				Right door
170	590002		-				Left door
180	590029		-				Foot
190	590030		-				Key board panel
200	590032		-				Center panel
210	590031		-				Serigraphy panel
220	590091		-				Panel tanks-drawer
230	590098		-				S/S screw M6x70
240	11168		-				S/S screw M6X12 TCB large 13x3
250	590720		-				Side panels insulating kit
255	590127		-				Side panels and cover insultaing kit
260	590070		-				Rack rails
265	13317		-				Ø 40 lead through rubber (minimum 2 pieces)

e=ELECTRONICAL SWITCHES, uw=LOWER AND UPPER WASHER

127EU=127EU

A=3/N/PE~380-400V 50-60Hz, D=3/PE~200-210V 50-60Hz, F=2/PE~220-240V 50-60Hz, G=3/N/PE~415V 50-60Hz, H=3/PE~220-230V 50-60Hz, K=3/PE~380-400V 50-60Hz, L=3/PE~415V 50-60Hz, M=3/PE~440V 60Hz, P=1/N/PE~220-230V 50-60Hz, R=2/PE~220-240V 50-60Hz, U=1/N/PE~240V 50-60Hz, V=3/PE~240V 50-60Hz, W=1/N/PE~100-110V 50-60Hz

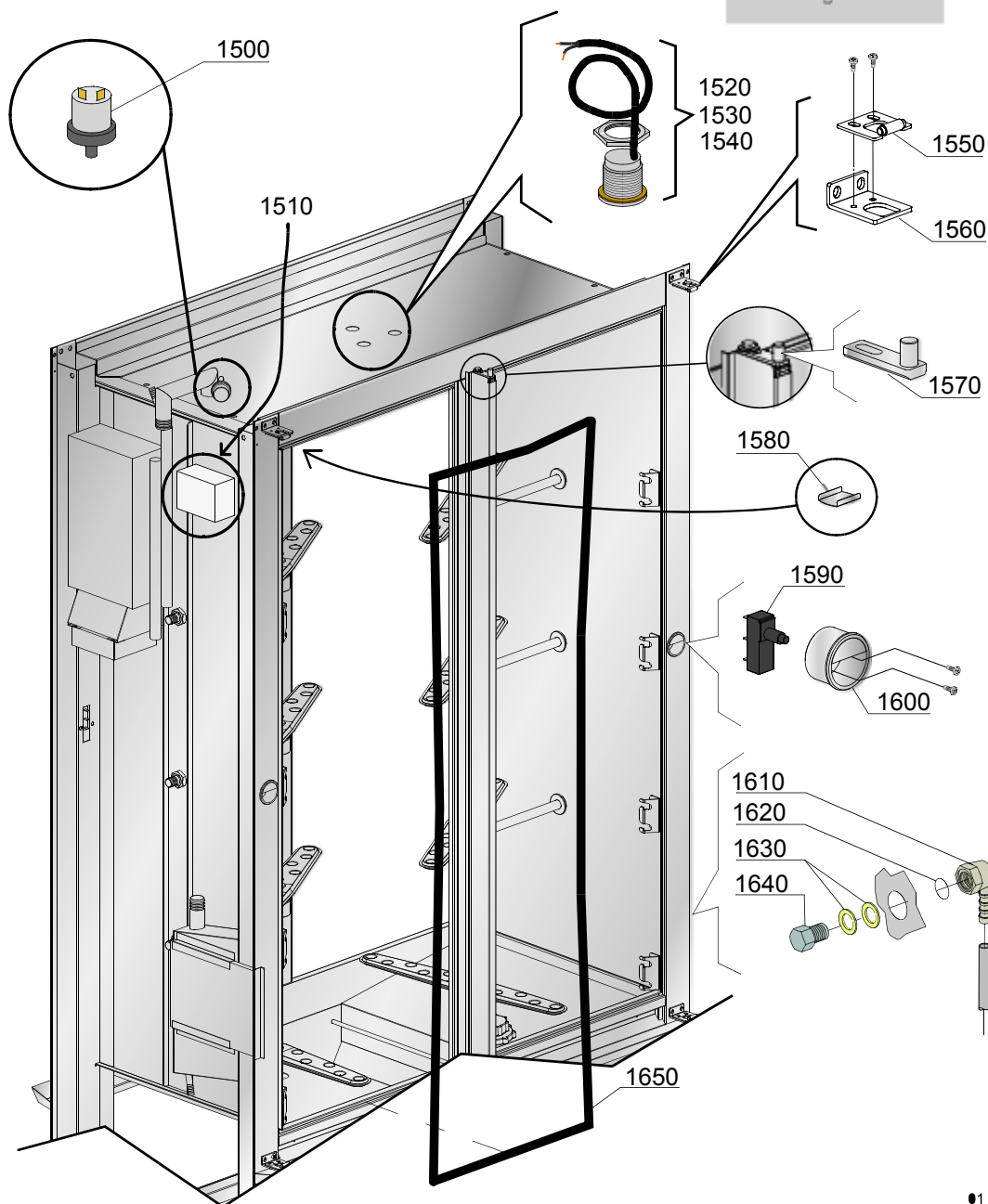

01_003_e

vsezip.ru

ID	P-code	SN from	SN to	Mod	Acces	Volt	Description
Module:General body parts							
1500	590100		-				Vacuum-switch sensor
1510	96210		-				Fan-cables junction box
1520	590065		-				Red LED
1530	590066		-				Blue LED
1540	590067		-				Green LED
1550	590026		-				Door-lock plate
1560	590025		-				Fixing plate
1570	590093		-				Adjustable hinge
1580	590037		-				Splash-plate
1590	590021		-				Door micro-switch
1600	590092		-				Door pawl
1610	3003129		-				Elbow hose-connection
1620	3003130		-				O-Ring
1630	3009387		-				Washer
1640	3003128		-				Elbow
1650	590034		-				Door gasket

e=ELECTRONICAL SWITCHES, uw=LOWER AND UPPER WASHER

127EU=127EU

A=3/N/PE~380-400V 50-60Hz, D=3/PE~200-210V 50-60Hz, F=2/PE~220-240V 50-60Hz, G=3/N/PE~415V 50-60Hz, H=3/PE~220-230V 50-60Hz, K=3/PE~380-400V 50-60Hz, L=3/PE~415V 50-60Hz, M=3/PE~440V 60Hz, P=1/N/PE~220-230V 50-60Hz, R=2/PE~220-240V 50-60Hz, U=1/N/PE~240V 50-60Hz, V=3/PE~240V 50-60Hz, W=1/N/PE~100-110V 50-60Hz

vsezip.ru

+7(812)987-08-81

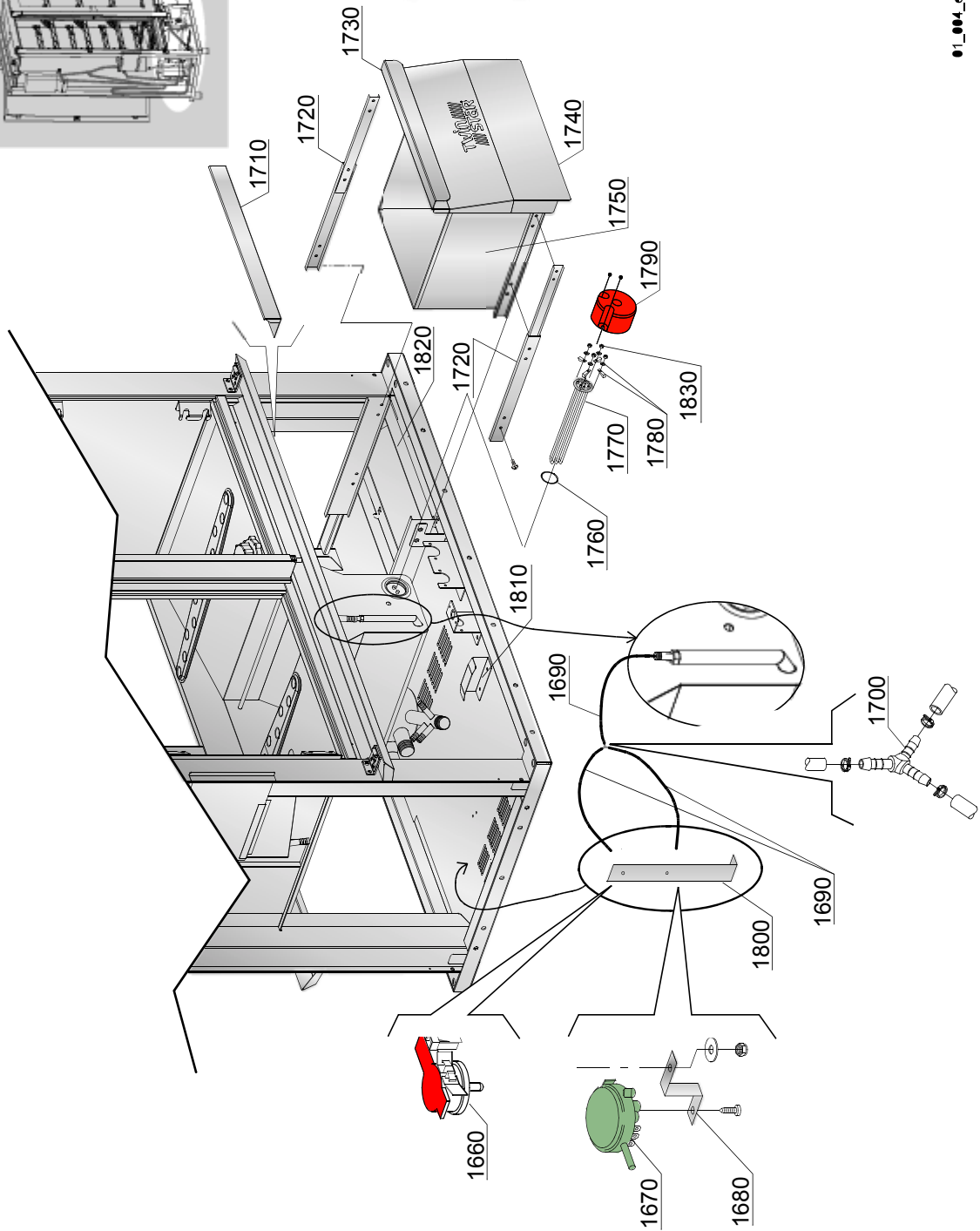
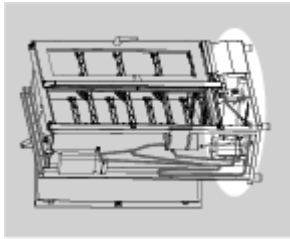

01_004_с

vsezip.ru

ID	P-code	SN from	SN to	Mod.	Acces	Volt	Description
Module:General body parts							
1660	540205		-				Linear pressure-switch
1670	88110		-				250/40 Pressure-switch
1680	3009363		-				Pressure-switch support
1690	14508		-				Hose 4.5x9 pressure-switch
1700	540094		-				Ø6 MM plastic 3 ways connection
1710	590050		-				Fascia
1720	590028		-				Drawer supports (pair)
1730	590051		-				Drawer handle
1740	590091		-				Panel tanks-drawer
1750	590027		-				Tanks-drawer
1760	13005		-				O-Ring 151 NBR
1770	590121		-				Heating element 6000/6530W 230/240V 3 (since serial n° DWF1023828)
1770	590121		-				Heating element 6000/6530W 230/240V 3 (from serial n° DWG1003423)
1780	11813		-				Heating element clamp (since serial n° DWF1023828)
1790	75311		-				Heating element cover
1800	590038		-				Bracket for pressure-switch support
1810	590087		-				Electrical panel support
1820	590052		-				Bracket for drawer supports
1830	11210		-				M5 Brass nut (from serial n° DWG1003423)

e=ELECTRONICAL SWITCHES, uw=LOWER AND UPPER WASHER

127EU=127EU

A=3/N/PE~380-400V 50-60Hz, D=3/PE~200-210V 50-60Hz, F=2/PE~220-240V 50-60Hz, G=3/N/PE~415V 50-60Hz, H=3/PE~220-230V 50-60Hz, K=3/PE~380-400V 50-60Hz, L=3/PE~415V 50-60Hz, M=3/PE~440V 60Hz, P=1/N/PE~220-230V 50-60Hz, R=2/PE~220-240V 50-60Hz, U=1/N/PE~240V 50-60Hz, V=3/PE~240V 50-60Hz, W=1/N/PE~100-110V 50-60Hz

vsezip.ru

+7(812)987-08-81

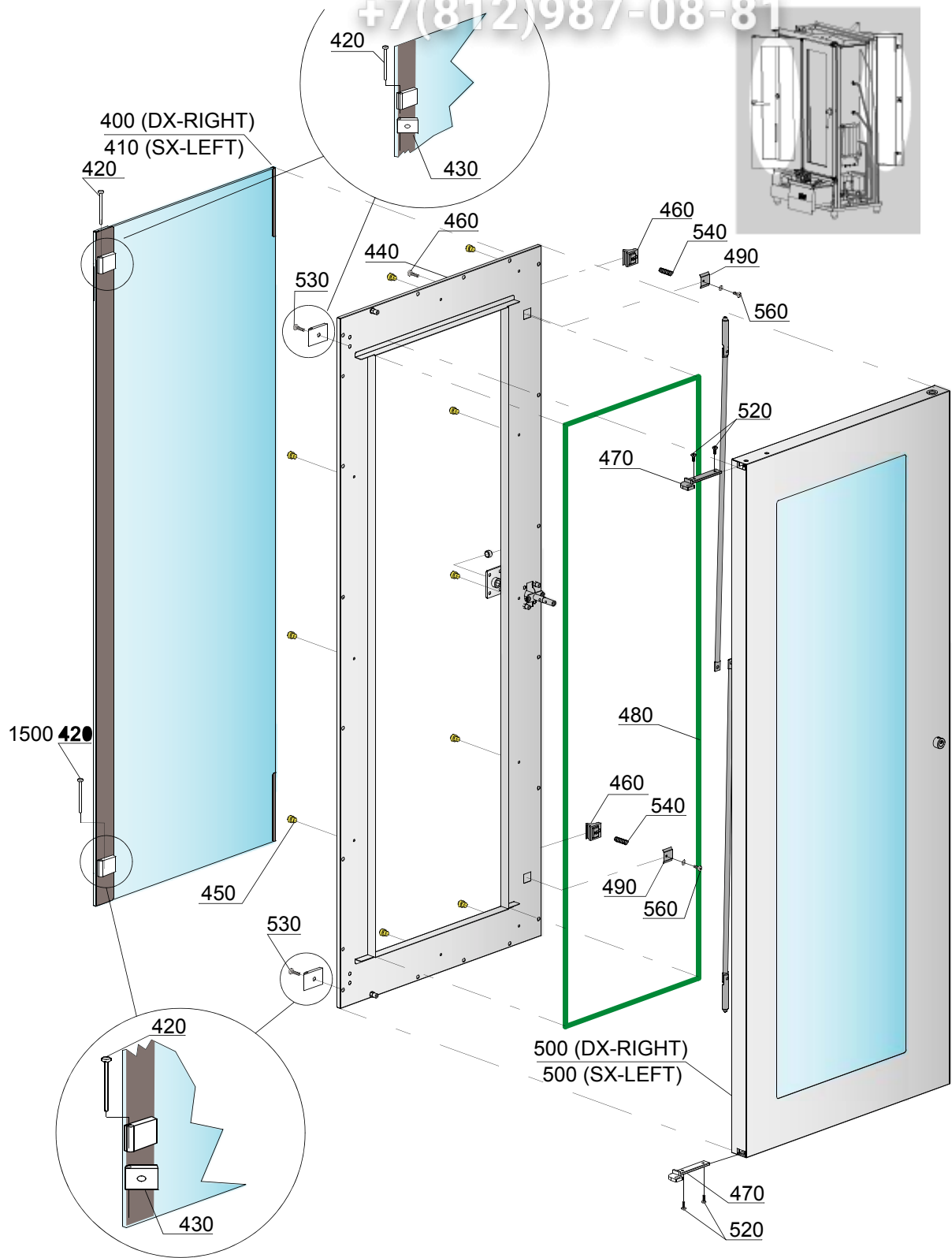

02_001_e

vsezip.ru

ID	P-code	SN from	SN to	Mod.	Acces.	Volt	Description
Module:Closing panelig							
400	590008		-				Inner glass right door assembly
410	590023		-				Inner glass left door assembly
420	590090		-				Glass protection hinge stud
430	590089		-				Glass protection hinge
440	590004		-				Inner frame door
450	590014		-				Glass stop plug
460	590012		-				Door glass lock
470	590015		-				Door/ingle protection
480	590013		-				Door glass gasket
490	590114		-				Door glass lock stop
500	590003		-				Outer frame right door
510	590022		-				Outer frame left door
520	11168		-				S/S screw M6X12 TCB large 13x3
530	11020		-				S/S screw M5X14 TSP self-locking
540	590115		-				S/S spring Ø6x18
550	11217		-				S/S screw M5x10
560	11131		-				S/S screw M4x10

e=ELECTRONICAL SWITCHES, uw=LOWER AND UPPER WASHER

127EU=127EU

A=3/N/PE~380-400V 50-60Hz, D=3/PE~200-210V 50-60Hz, F=2/PE~220-240V 50-60Hz, G=3/N/PE~415V 50-60Hz, H=3/PE~220-230V 50-60Hz, K=3/PE~380-400V 50-60Hz, L=3/PE~415V 50-60Hz, M=3/PE~440V 60Hz, P=1/N/PE~220-230V 50-60Hz, R=2/PE~220-240V 50-60Hz, U=1/N/PE~240V 50-60Hz, V=3/PE~240V 50-60Hz, W=1/N/PE~100-110V 50-60Hz

vsezip.ru

+7(812)987-08-81

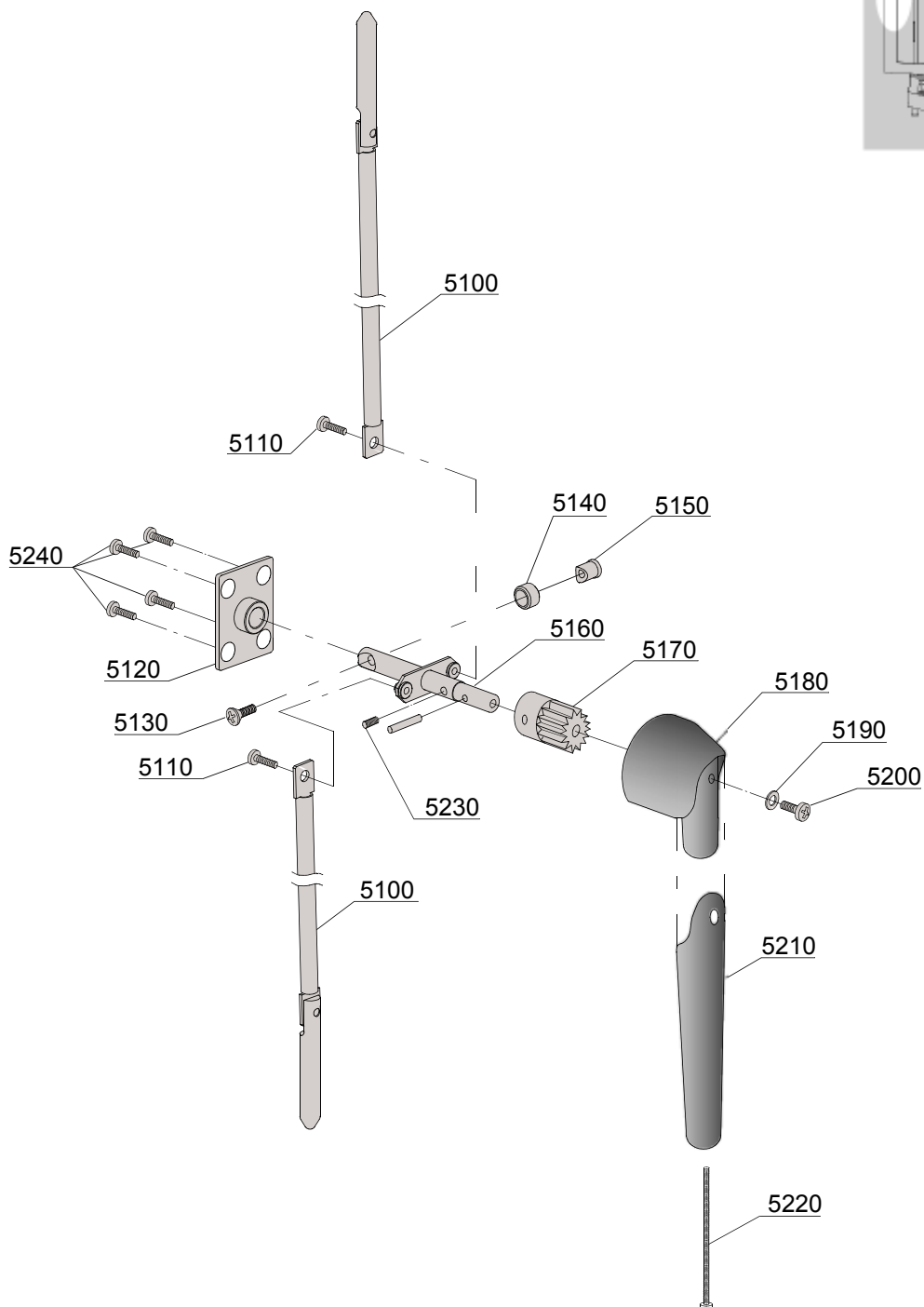
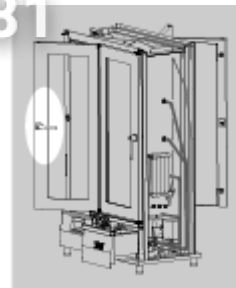

02_002_e

vsezip.ru

ID	P-code	SN from	SN to	Mod	Acces.	Volt	Description
Module:Handle							
5100	590005		-				Door shaft with terminal
5110	11217		-				S/S screw M5x10
5120	590007		-				Door gear flange
5130	590099		-				S/S screw M6x12 TC UNI 6110
5140	590020		-				Door handle roll
5150	590019		-				Door handle tooth
5160	590006		-				Door handle stud
5170	590018		-				Door handle gear
5180	590016		-				Door handle body
5190	11604		-				S/S grower M6
5200	11168		-				S/S screw M6X12 TCB large 13x3
5210	590017		-				Door handle
5220	590113		-				Stud screw A2 TSP 5X120 TC
5230	11505		-				S/S M6x16 dowel
5240	11141		-				S/S screw M6x16 TGS

e=ELECTRONICAL SWITCHES, uw=LOWER AND UPPER WASHER

127EU=127EU

A=3/N/PE~380-400V 50-60Hz, D=3/PE~200-210V 50-60Hz, F=2/PE~220-240V 50-60Hz, G=3/N/PE~415V 50-60Hz, H=3/PE~220-230V 50-60Hz, K=3/PE~380-400V 50-60Hz, L=3/PE~415V 50-60Hz, M=3/PE~440V 60Hz, P=1/N/PE~220-230V 50-60Hz, R=2/PE~220-240V 50-60Hz, U=1/N/PE~240V 50-60Hz, V=3/PE~240V 50-60Hz, W=1/N/PE~100-110V 50-60Hz

vsezip.ru

+7(812)987-08-81

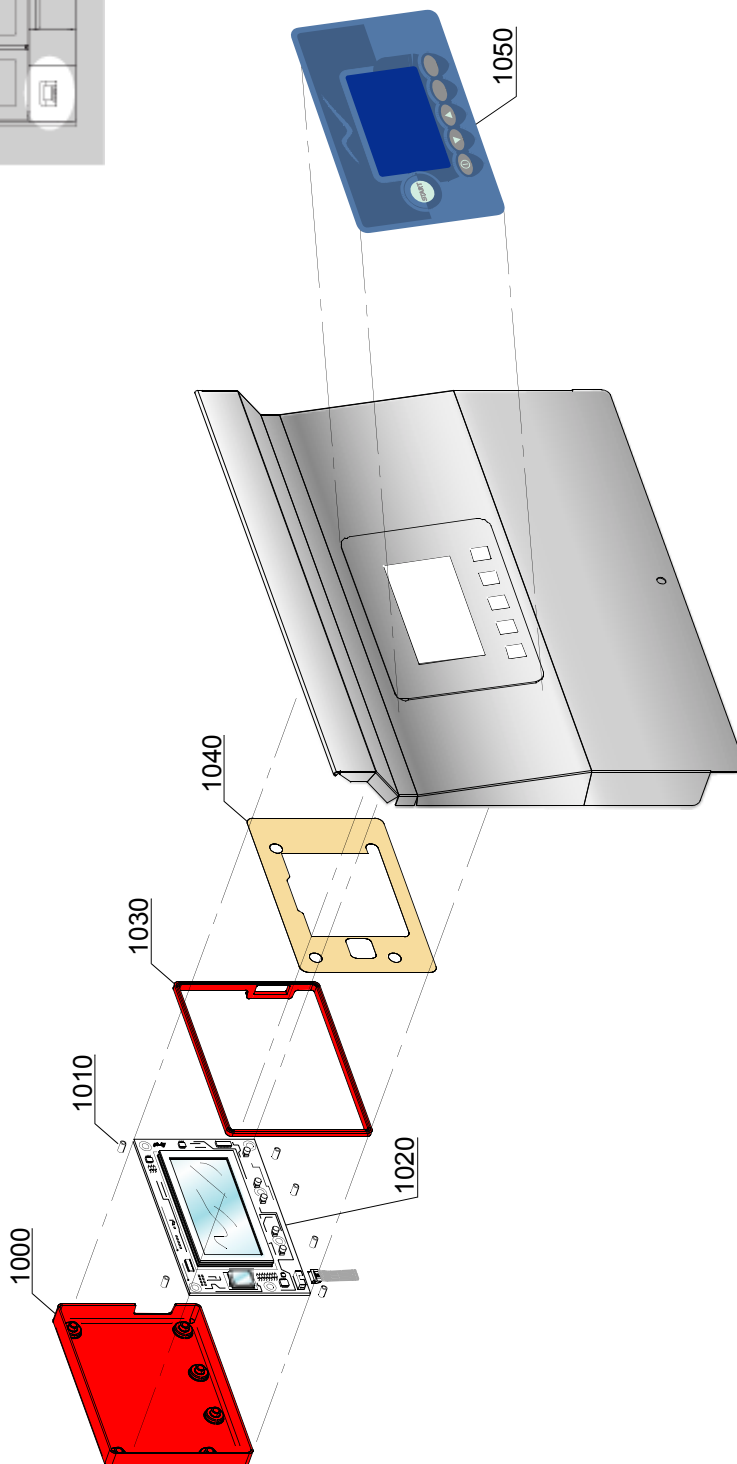
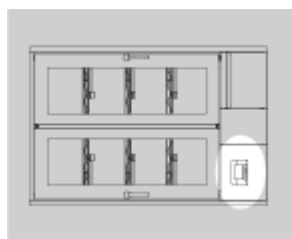

vsezip.ru

ID	P-code	SN from	SN to	Mod.	Acces.	Volt	Description
Module: Control panel and switches							
1000	590122		-				Board protection box
1010	50561		-				Circuit board stand
1020	590107		-				Key-board and display
1030	50650/B		-				Gasket for protection box
1040	96716		-				Display protection
1050	96704		-				Key-membrane

e=ELECTRONICAL SWITCHES, uw=LOWER AND UPPER WASHER

127EU=127EU

A=3/N/PE~380-400V 50-60Hz, D=3/PE~200-210V 50-60Hz, F=2/PE~220-240V 50-60Hz, G=3/N/PE~415V 50-60Hz,
 H=3/PE~220-230V 50-60Hz, K=3/PE~380-400V 50-60Hz, L=3/PE~415V 50-60Hz, M=3/PE~440V 60Hz, P=1/N/PE~220-
 230V 50-60Hz, R=2/PE~220-240V 50-60Hz, U=1/N/PE~240V 50-60Hz, V=3/PE~240V 50-60Hz, W=1/N/PE~100-110V
 50-60Hz

vsezip.ru

+7(812)987-08-81

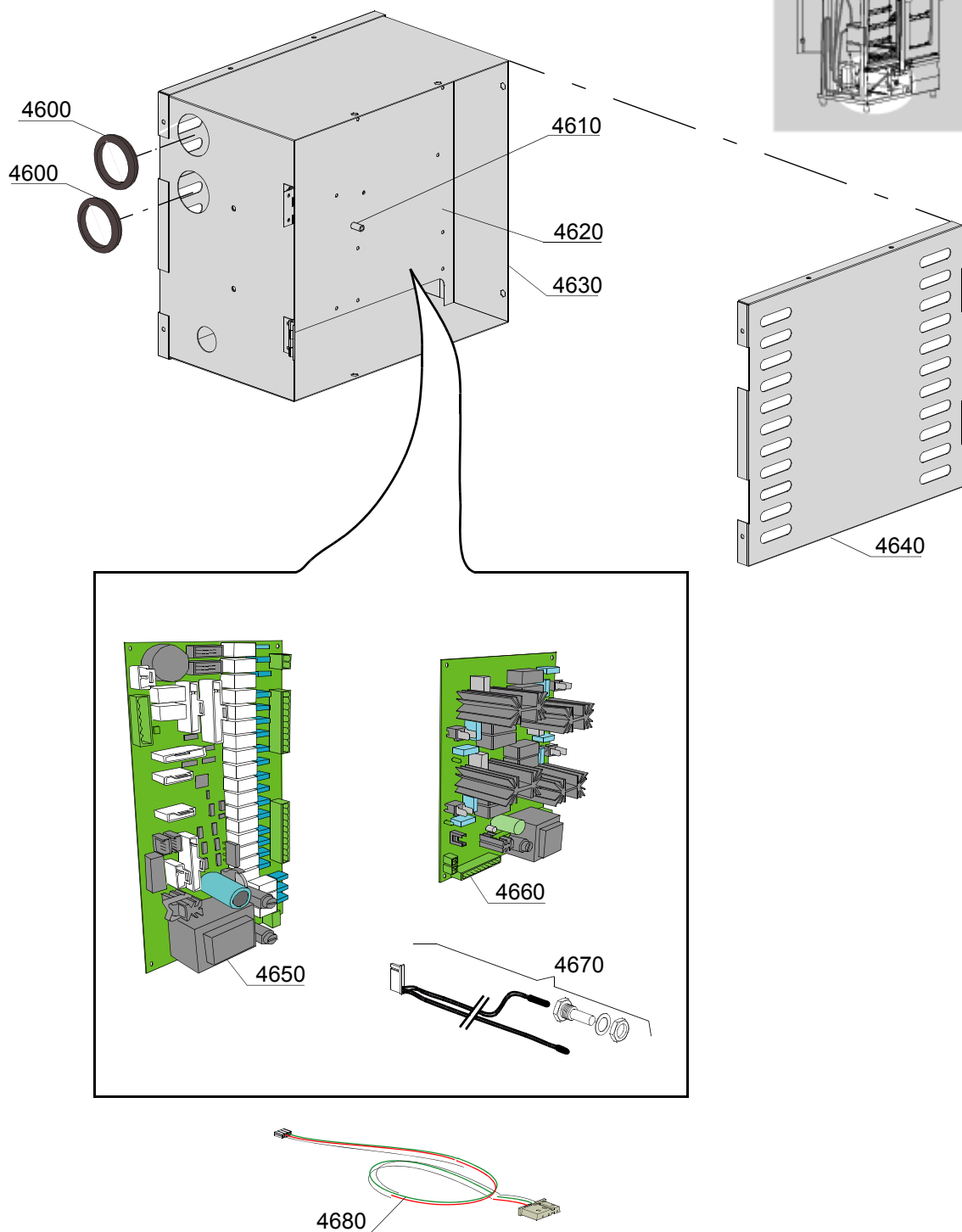

04_001_e

vsezip.ru

ID	P-code	SN from	SN to	Mod.	Acces.	Volt	Description
Module: Electric control components							
4600	13324		-				Lead through rubber Ø46x50mm
4610	50586		-				Key-board spacer
4620	590086		-				Components rail
4630	590035		-				Electrical panel
4640	590085		-				Electrical panel cover
4650	50605		-				Main board J104 (no software)
4660	50606		-				Expansion board M075 (no software)
4670	590104		-				Wash tank & wash chamber sensor
4680	6106504		-				Cabling linear pressure-switch

e=ELECTRONICAL SWITCHES, uw=LOWER AND UPPER WASHER

127EU=127EU

A=3/N/PE~380-400V 50-60Hz, D=3/PE~200-210V 50-60Hz, F=2/PE~220-240V 50-60Hz, G=3/N/PE~415V 50-60Hz, H=3/PE~220-230V 50-60Hz, K=3/PE~380-400V 50-60Hz, L=3/PE~415V 50-60Hz, M=3/PE~440V 60Hz, P=1/N/PE~220-230V 50-60Hz, R=2/PE~220-240V 50-60Hz, U=1/N/PE~240V 50-60Hz, V=3/PE~240V 50-60Hz, W=1/N/PE~100-110V 50-60Hz

vsezip.ru

+7(812)987-08-81

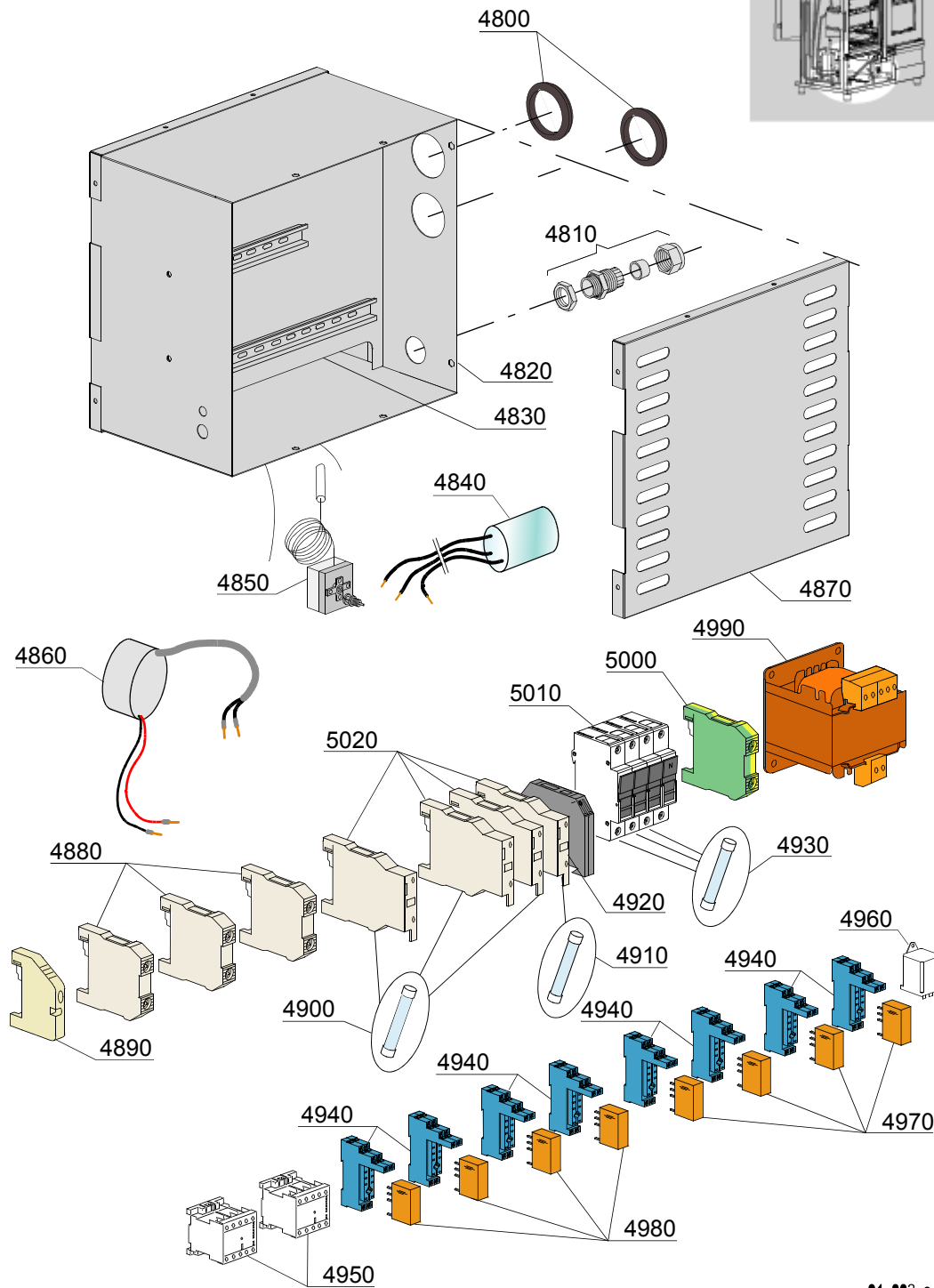

04_002_e

ID	P-code	SN from	SN to	Mod	Acces.	Volt	Description
Module: Electric control components							
4800	13324		-				Lead through rubber Ø46x50mm
4810	80414		-				Cable penetration with ring-nut
4820	590035		-				Electrical panel
4830	590086		-				Components rail
4840	15149		-				Noise filter
4850	2000430		-				Safety thermostat
4860	590068		-				LED feeder
4870	590085		-				Electrical panel cover
4880	3006092		-				4mmq clamp
4890	3006093		-				Slide DIN retainer
4900	15163		-				5x20 1A fuse (3 pieces)
4910	15212		-				5x20 6,3A fuse (3 pieces)
4920	3006144		-				Fuse holder covering plate
4930	3006095		-				10x38 16A fuse (3 pieces)
4940	3006079		-				Base for relay
4950	15086		-				Contactora 230V 50/60Hz 4C
4960	16047		-				16A 230VAC 50/60Hz tipolar relay
4970	3006178		-				2C/DEV. 230V relay
4980	3006078		-				2C/DEV. 24V relay
4990	3006060		-				160VA 0-230-400-415-440/0-24V transformer
5000	10300401		-				6/8mmq yellow/green clamp
5010	3006179		-				Fuse holder terminal board
5020	3006147		-				Fuse holder clamp

e=ELECTRONICAL SWITCHES, uw=LOWER AND UPPER WASHER

127EU=127EU

A=3/N/PE~380-400V 50-60Hz, D=3/PE~200-210V 50-60Hz, F=2/PE~220-240V 50-60Hz, G=3/N/PE~415V 50-60Hz, H=3/PE~220-230V 50-60Hz, K=3/PE~380-400V 50-60Hz, L=3/PE~415V 50-60Hz, M=3/PE~440V 60Hz, P=1/N/PE~220-230V 50-60Hz, R=2/PE~220-240V 50-60Hz, U=1/N/PE~240V 50-60Hz, V=3/PE~240V 50-60Hz, W=1/N/PE~100-110V 50-60Hz

vsezip.ru

+7(812)987-08-81

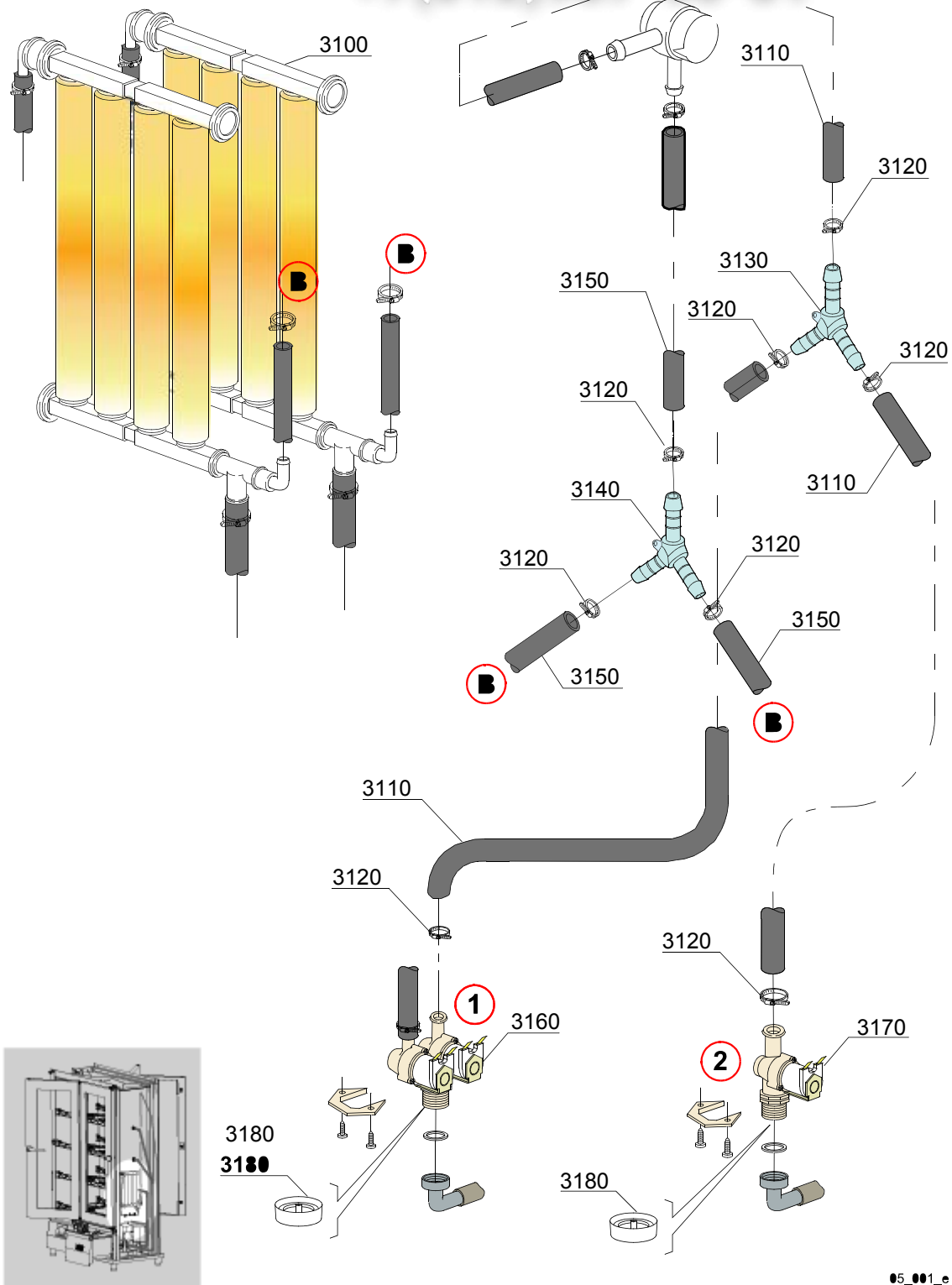

05_001_e

vsezip.ru

ID	P-code	SN from	SN to	Mod.	Acces.	Volt	Description
Module: Water softner group							
3100	16066		-				4 elements softener
3110	2907350		-				Rubber hose EPDM 12x20
3120	11807		-				12/22 clamp in AISI 430
3130	540091		-				Ø12 mm plastic 3 ways connection
3140	540090		-				Ø10 mm plastic 3 ways connection
3150	14506		-				Rubber hose Ø9,5x16 EPDM
3160	15098		-				Double-body solenoid valve
3170	10703		-				Solenoid valve
3180	15286		-				Non return valve

e=ELECTRONICAL SWITCHES, uw=LOWER AND UPPER WASHER

127EU=127EU

A=3/N/PE~380-400V 50-60Hz, D=3/PE~200-210V 50-60Hz, F=2/PE~220-240V 50-60Hz, G=3/N/PE~415V 50-60Hz, H=3/PE~220-230V 50-60Hz, K=3/PE~380-400V 50-60Hz, L=3/PE~415V 50-60Hz, M=3/PE~440V 60Hz, P=1/N/PE~220-230V 50-60Hz, R=2/PE~220-240V 50-60Hz, U=1/N/PE~240V 50-60Hz, V=3/PE~240V 50-60Hz, W=1/N/PE~100-110V 50-60Hz

vsezip.ru

+7(812)987-08-81

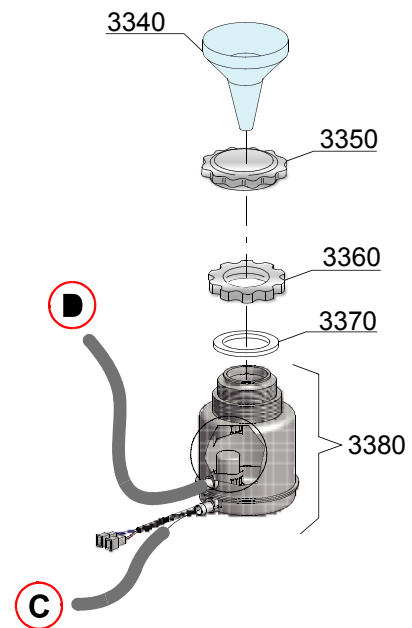
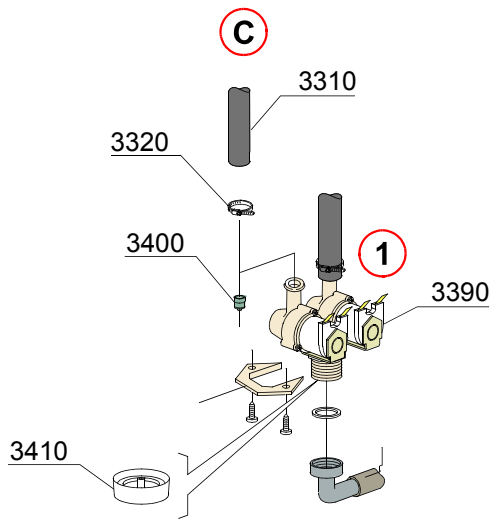
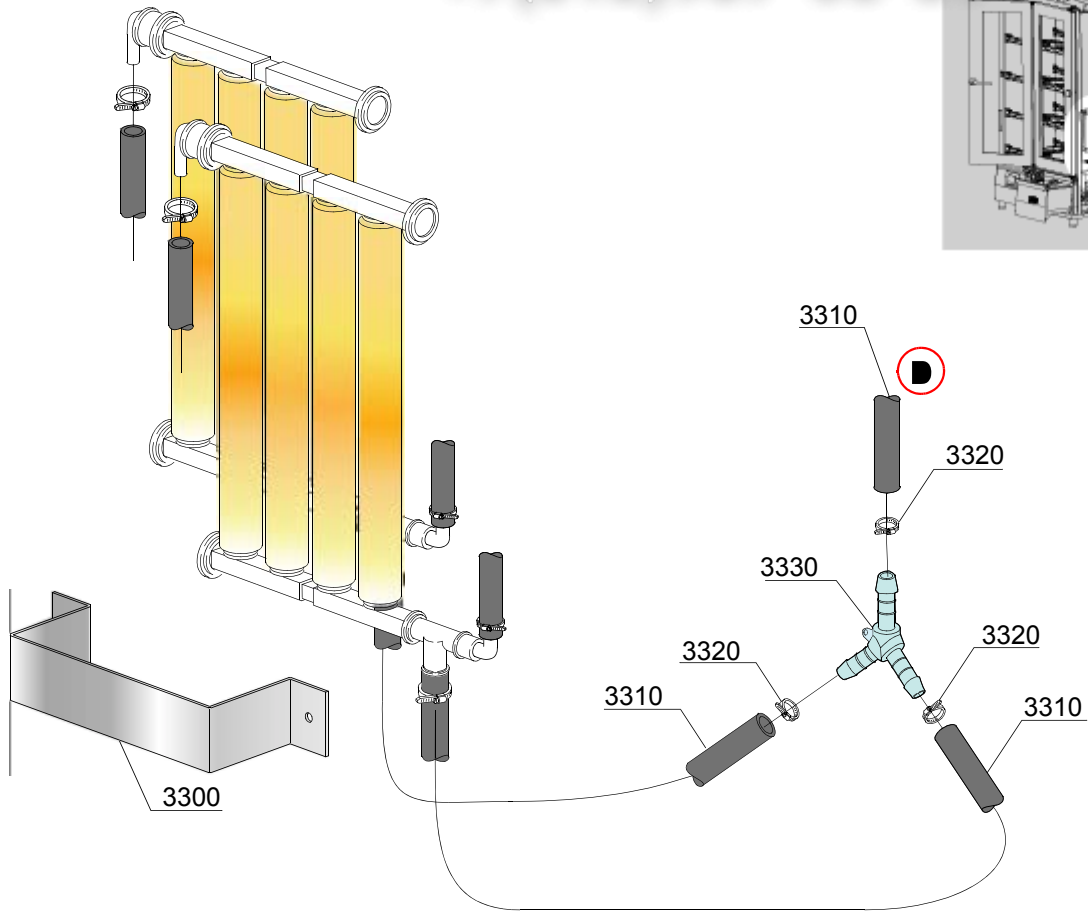
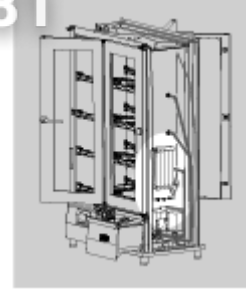

05_002_e

ID	P-code	SN from	SN to	Mod.	Acces.	Volt	Description
Module: Water softner group							
3300	590042		-				Softeners support bar
3310	14506		-				Rubber hose Ø9,5x16 EPDM
3320	11807		-				12/22 clamp
3330	540090		-				Ø10 MM plastic 3 ways connection
3340	16082		-				Funnel
3350	16067/D		-				Plug salt bowl
3360	16067/C		-				Ring nut salt bowl
3370	16067/B		-				Gasket salt bowl
3380	16072		-				Salt bowl (with sensor)
3390	15098		-				Double-body solenoid valve
3400	15115		-				Outlet flow reducer
3410	15286		-				Flow reducer

e=ELECTRONICAL SWITCHES, uw=LOWER AND UPPER WASHER

127EU=127EU

A=3/N/PE~380-400V 50-60Hz, D=3/PE~200-210V 50-60Hz, F=2/PE~220-240V 50-60Hz, G=3/N/PE~415V 50-60Hz, H=3/PE~220-230V 50-60Hz, K=3/PE~380-400V 50-60Hz, L=3/PE~415V 50-60Hz, M=3/PE~440V 60Hz, P=1/N/PE~220-230V 50-60Hz, R=2/PE~220-240V 50-60Hz, U=1/N/PE~240V 50-60Hz, V=3/PE~240V 50-60Hz, W=1/N/PE~100-110V 50-60Hz

vsezip.ru

+7(812)987-08-81

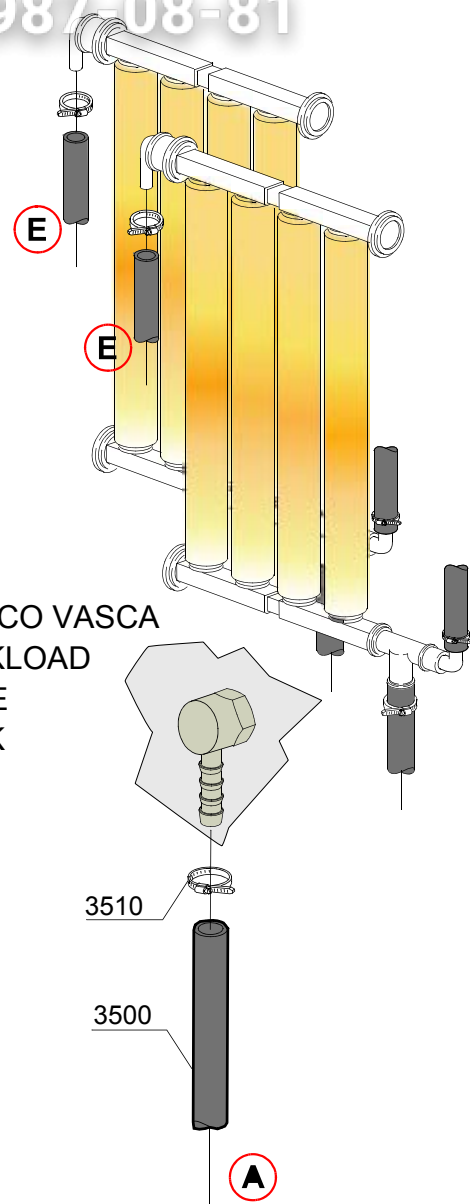
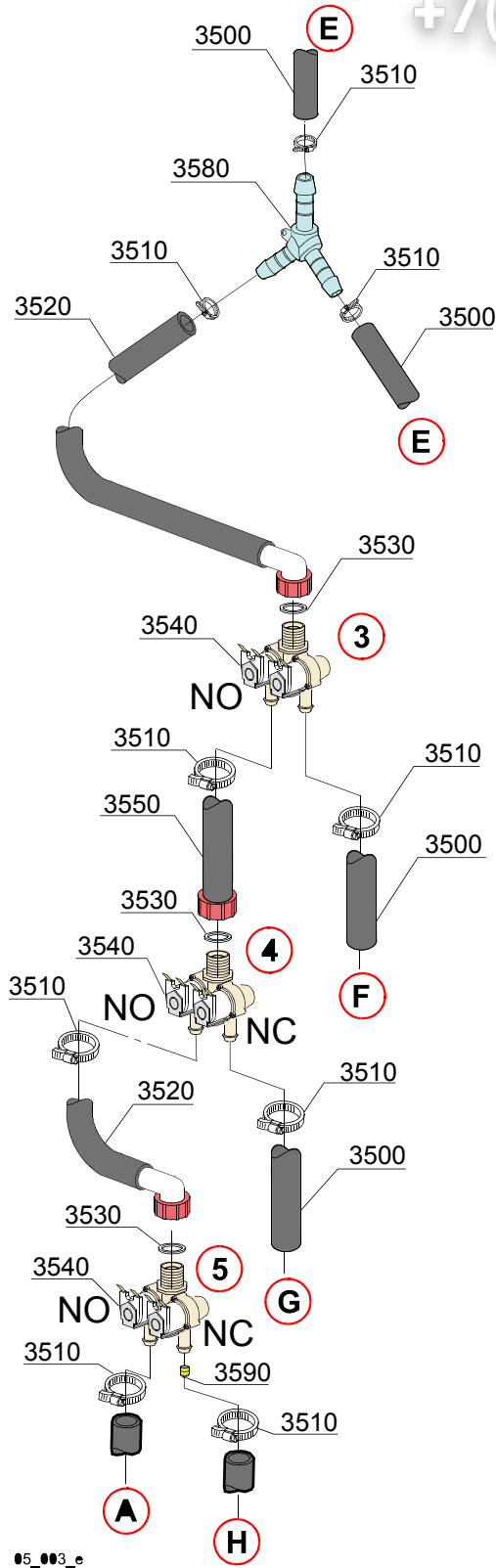

CARICO VASCA
TANKLOAD
CUVE
TANK

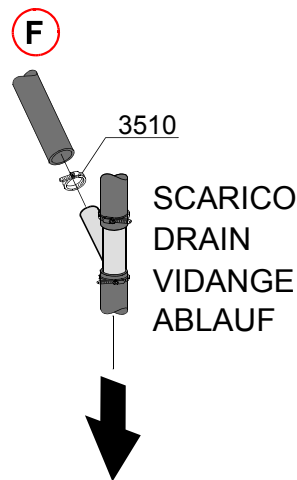

SCARICO
DRAIN
VIDANGE
ABLAUF



05_003_e

vsezip.ru

ID	P-code	SN from	SN to	Mod	Acces	Volt	Description
Module: Water softner group							
3500	14506		-				Rubber hose Ø9,5x16 EPDM
3510	11807		-				12/22 clamp
3520	10766		-				90° connection hose to solenoid valve
3530	13307		-				Gasket 3/4 intake
3540	15214		-				Solenoid valve 3/4
3550	10767		-				Straight connection hose to solenoid valve
3560	2907353		-				EPDM 11x18 KTW flexible pipe
3570	2907350		-				Rubber hose EPDM 12x20
3580	540090		-				Ø10 MM plastic 3 ways connection
3590	15115/G		-				

e=ELECTRONICAL SWITCHES, uw=LOWER AND UPPER WASHER

127EU=127EU

A=3/N/PE~380-400V 50-60Hz, D=3/PE~200-210V 50-60Hz, F=2/PE~220-240V 50-60Hz, G=3/N/PE~415V 50-60Hz, H=3/PE~220-230V 50-60Hz, K=3/PE~380-400V 50-60Hz, L=3/PE~415V 50-60Hz, M=3/PE~440V 60Hz, P=1/N/PE~220-230V 50-60Hz, R=2/PE~220-240V 50-60Hz, U=1/N/PE~240V 50-60Hz, V=3/PE~240V 50-60Hz, W=1/N/PE~100-110V 50-60Hz

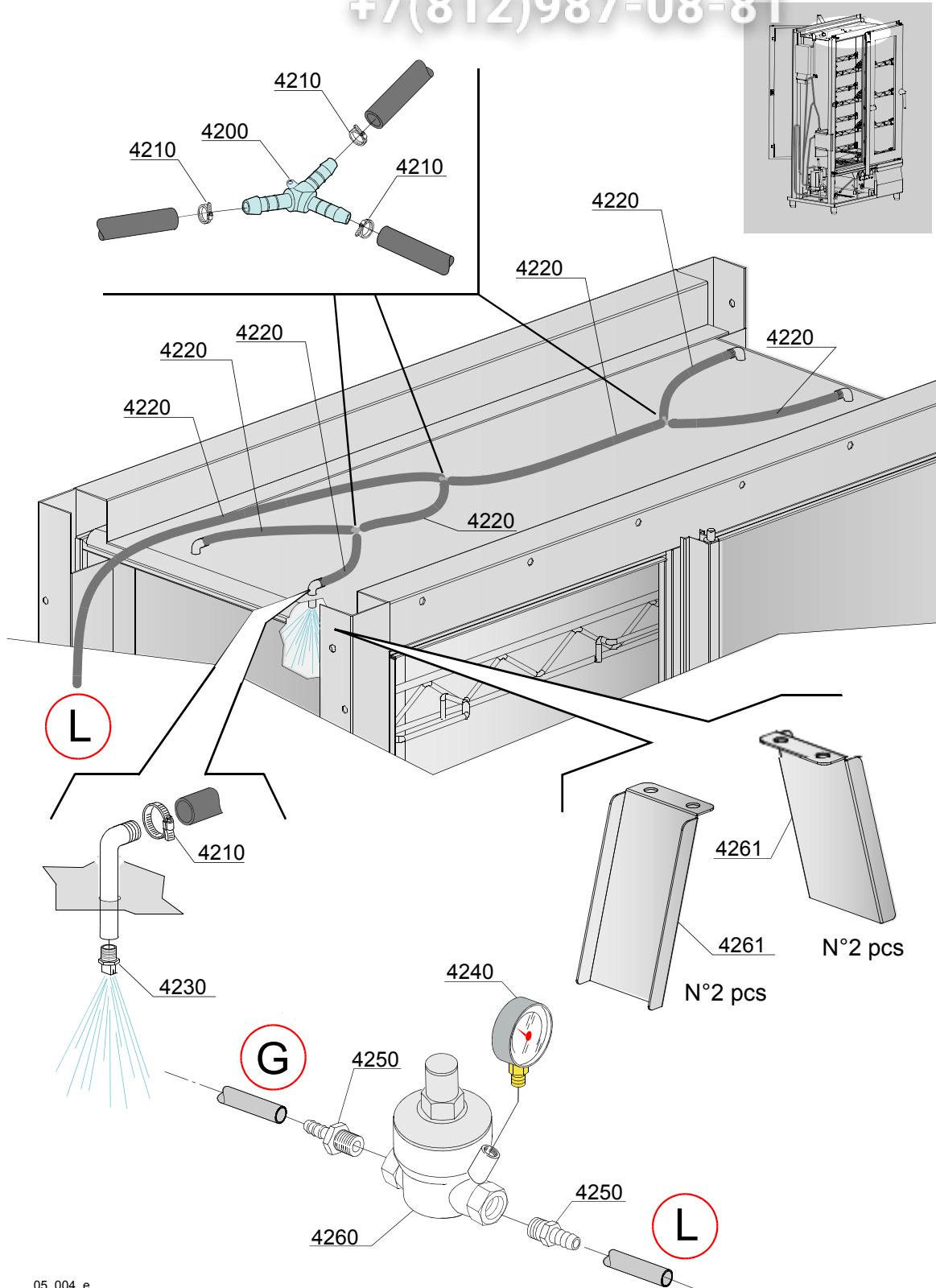

05_004_e

vsezip.ru

ID	P-code	SN from	SN to	Mod	Acces.	Volt	Description
Module:Condensing							
4200	540090		-				Ø10 MM plastic 3 ways connection
4210	11807		-				12/22 clamp
4220	14506		-				Rubber hose Ø9,5x16 EPDM
4230	590064		-				S/S blade nozzle 1/8MC3E-04/95°
4240	2000244		-				Gauge
4250	12023		-				Hose connection M1/2 Ø12
4260	391025		-				Pressure reducer
4261	590123		-				Splash zone

e=ELECTRONICAL SWITCHES, uw=LOWER AND UPPER WASHER

127EU=127EU

A=3/N/PE~380-400V 50-60Hz, D=3/PE~200-210V 50-60Hz, F=2/PE~220-240V 50-60Hz, G=3/N/PE~415V 50-60Hz, H=3/PE~220-230V 50-60Hz, K=3/PE~380-400V 50-60Hz, L=3/PE~415V 50-60Hz, M=3/PE~440V 60Hz, P=1/N/PE~220-230V 50-60Hz, R=2/PE~220-240V 50-60Hz, U=1/N/PE~240V 50-60Hz, V=3/PE~240V 50-60Hz, W=1/N/PE~100-110V 50-60Hz

vsezip.ru

+7(812)987-08-81

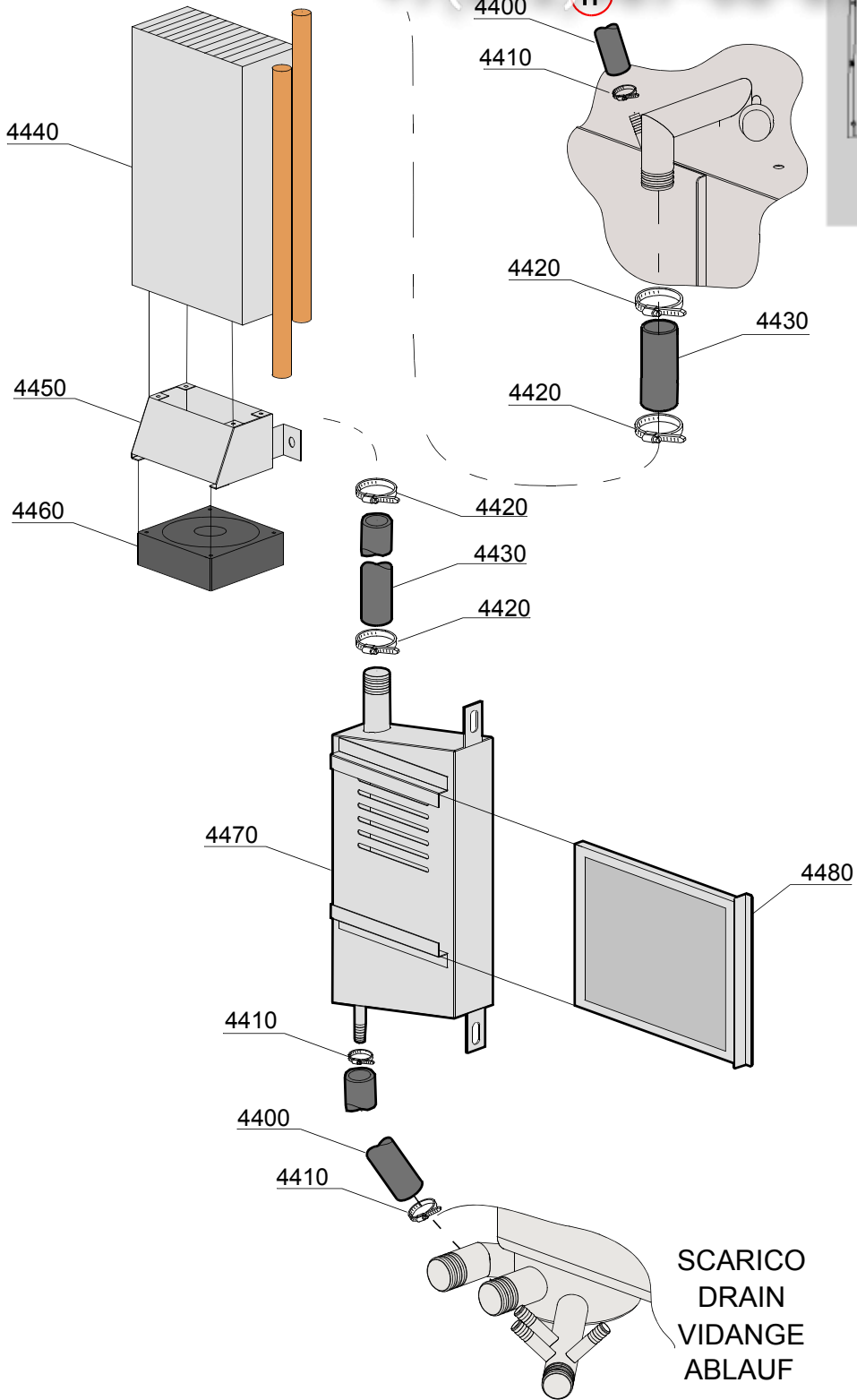

05_005_e

vsezip.ru

ID	P-code	SN from	SN to	Mod.	Acces	Volt	Description
Module:Condensing							
4400	14506		-				Rubber hose Ø9,5x16 EPDM
4410	11807		-				12/22 clamp
4420	11806		-				25/40 clamp
4430	3060270		-				Ø30 elbow coupling
4440	590063		-				Steam condensing unit
4450	590036		-				Fan stand
4460	3000118		-				Inverter Fan
4470	590095		-				Condense collection assembly
4480	590097		-				Battery filter

e=ELECTRONICAL SWITCHES, uw=LOWER AND UPPER WASHER

127EU=127EU

A=3/N/PE~380-400V 50-60Hz, D=3/PE~200-210V 50-60Hz, F=2/PE~220-240V 50-60Hz, G=3/N/PE~415V 50-60Hz, H=3/PE~220-230V 50-60Hz, K=3/PE~380-400V 50-60Hz, L=3/PE~415V 50-60Hz, M=3/PE~440V 60Hz, P=1/N/PE~220-230V 50-60Hz, R=2/PE~220-240V 50-60Hz, U=1/N/PE~240V 50-60Hz, V=3/PE~240V 50-60Hz, W=1/N/PE~100-110V 50-60Hz

vsezip.ru

+7(812)987-08-81

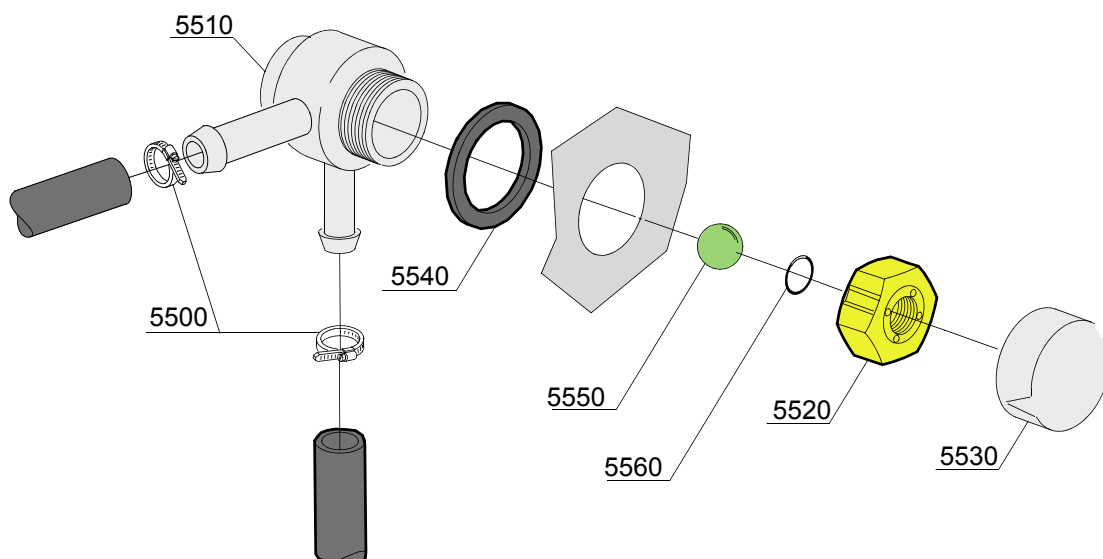
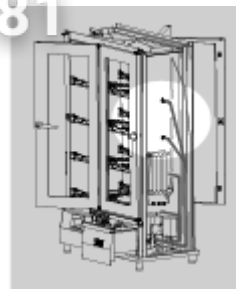

00_001_e

vsezip.ru

ID	P-code	SN from	SN to	Mod	Acces	Volt	Description
Module: DVGW valve							
5500	11807		-				Clamp AISI 430 12/22
5510	15280		-				Valve body center
5520	15281		-				Valve nut
5530	15282		-				Valve nut cover
5540	15283		-				Valve gasket
5550	15284		-				Sphere
5560	15285		-				O-ring 115 KTW

e=ELECTRONICAL SWITCHES, uw=LOWER AND UPPER WASHER

127EU=127EU

A=3/N/PE~380-400V 50-60Hz, D=3/PE~200-210V 50-60Hz, F=2/PE~220-240V 50-60Hz, G=3/N/PE~415V 50-60Hz,
H=3/PE~220-230V 50-60Hz, K=3/PE~380-400V 50-60Hz, L=3/PE~415V 50-60Hz, M=3/PE~440V 60Hz, P=1/N/PE~220-
230V 50-60Hz, R=2/PE~220-240V 50-60Hz, U=1/N/PE~240V 50-60Hz, V=3/PE~240V 50-60Hz, W=1/N/PE~100-110V
50-60Hz

vsezip.ru

+7(812)987-08-81

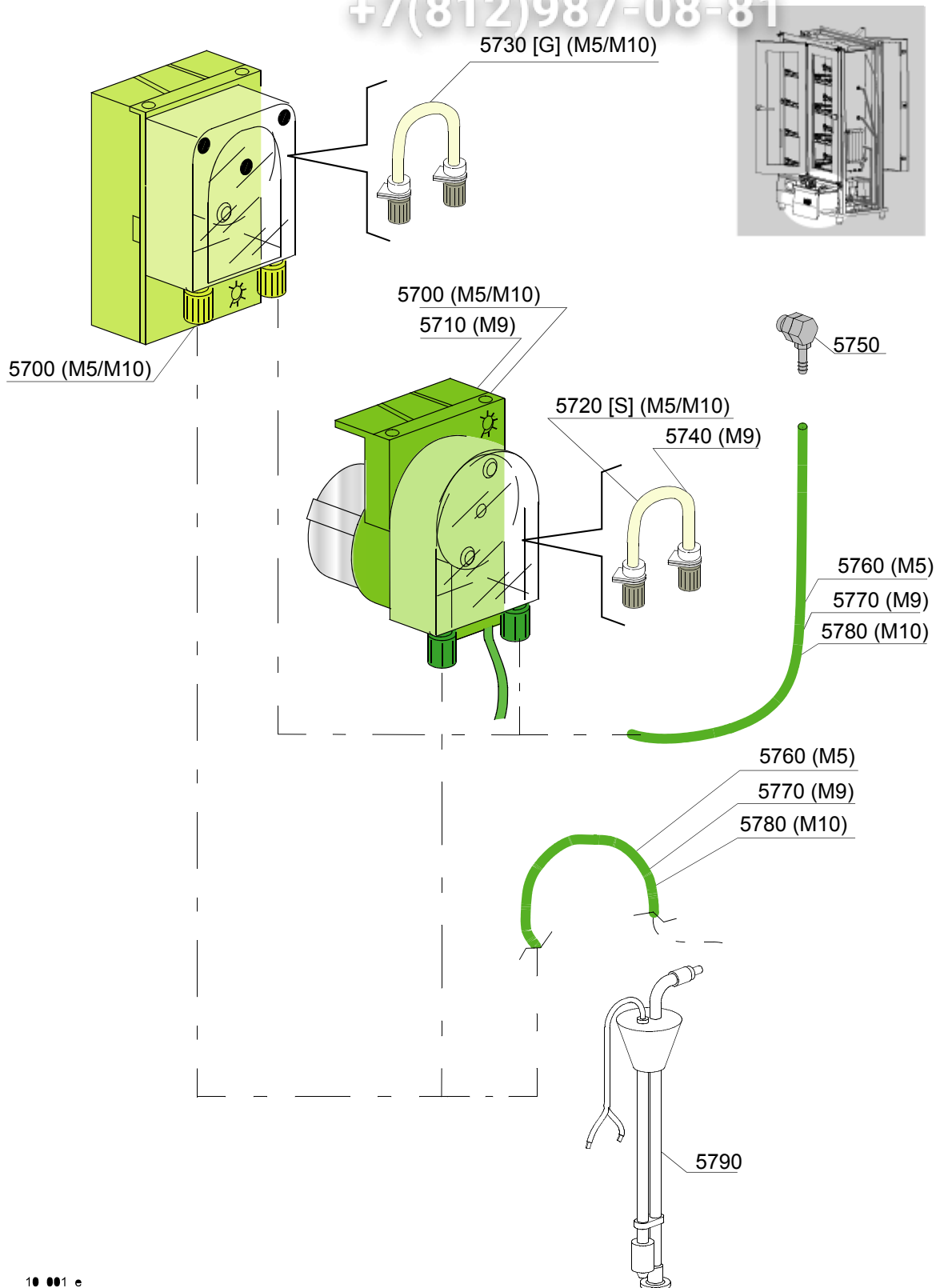

10_001_e

ID	P-code	SN from	SN to	Mod.	Acces.	Volt	Description
Module: Rinse aid dispenser group							
5700	15985		-				Adjustable 0-3lt/h detergent/sanitizer dosing pump [M5/M10]
5710	15985/B		-				Adjustable 0-3lt/h rinse aid dosing pump [M9]
5720	15185		-				Detergent/sanitizer dosing pump thermoplastic hose [S-M5/M10]
5730	15108/E		-				Detergent/sanitizer dosing pump thermoplastic hose [G-M5/M9]
5740	15186/T		-				Rinse aid dosing pump thermoplastic hose [M9]
5750	15123		-				S/S injector
5760	14503		-				Ø6x4 PVC transparent hose [M5]
5770	14502/A		-				Ø6x4 PVC green hose [M9]
5780	14511		-				Ø6x4 PVC red hose [M10]
5790	590118		-				Level sensor detergent/sanitizer/rinse aid

e=ELECTRONICAL SWITCHES, uw=LOWER AND UPPER WASHER

127EU=127EU

A=3/N/PE~380-400V 50-60Hz, D=3/PE~200-210V 50-60Hz, F=2/PE~220-240V 50-60Hz, G=3/N/PE~415V 50-60Hz, H=3/PE~220-230V 50-60Hz, K=3/PE~380-400V 50-60Hz, L=3/PE~415V 50-60Hz, M=3/PE~440V 60Hz, P=1/N/PE~220-230V 50-60Hz, R=2/PE~220-240V 50-60Hz, U=1/N/PE~240V 50-60Hz, V=3/PE~240V 50-60Hz, W=1/N/PE~100-110V 50-60Hz

vsezip.ru

+7(812)987-08-81

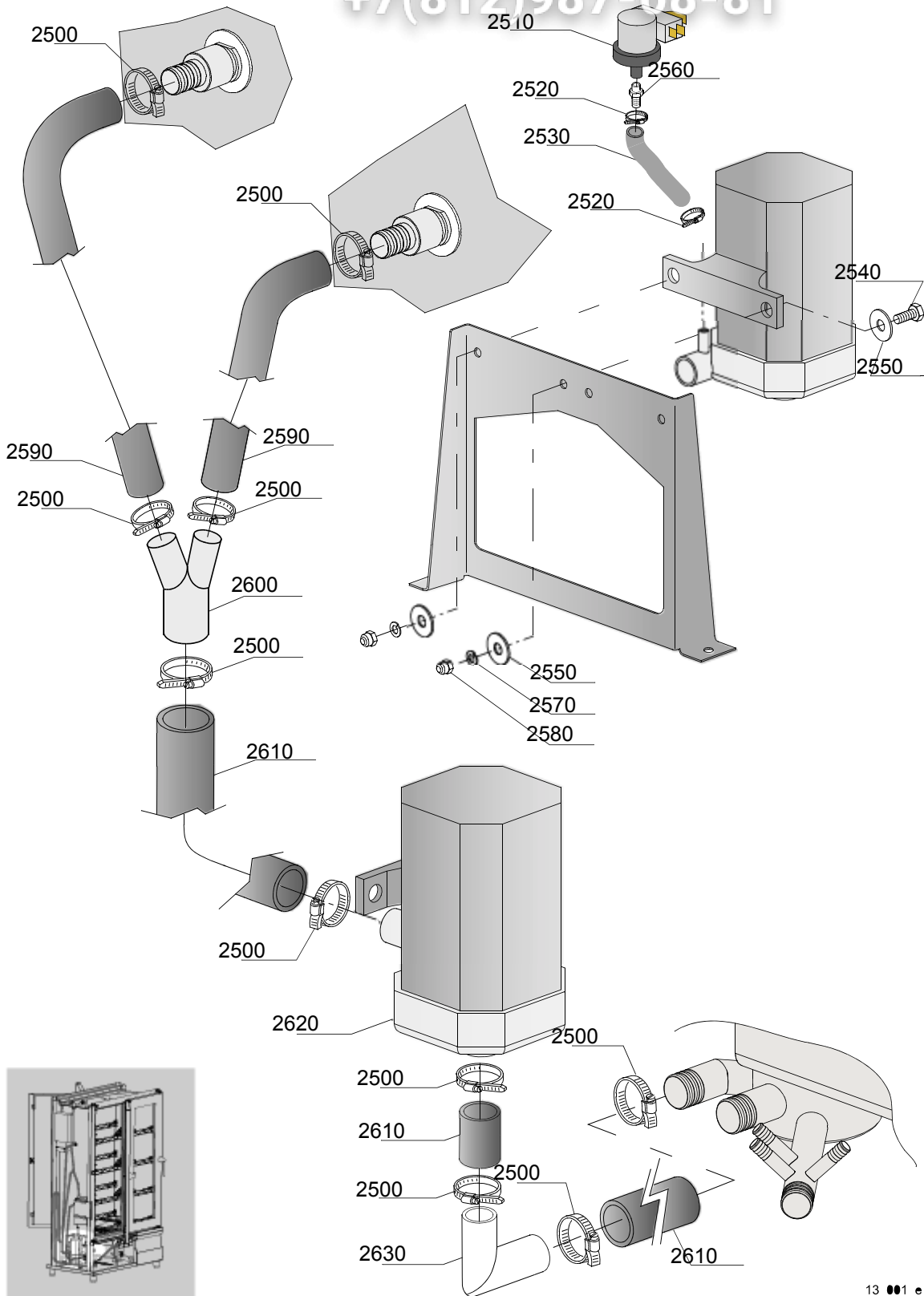

13_001_e

vsezip.ru

ID	P-code	SN from	SN to	Mod	Acces	Volt	Description
Module: Wash pump group							
2500	11806		-				AISI 430 25/40 clamp
2510	3060195		-				Pressure switch
2520	11807		-				AISI 430 12/22 clamp
2530	14506		-				Rubber hose Ø9,5x16 EPDM
2540	11104/B		-				S/S screw M6x16 TE
2550	11178		-				S/S washer 6x18
2560	590048		-				Pumps stand
2570	11604		-				S/S grower M6
2580	11706		-				S/S nut M6
2590	92104		-				Supply hose side arms
2600	590045		-				S/S "Y" connection
2610	3060270		-				Hose Ø30
2620	590108		-				Pump HP0.7 230V.50Hz - internal
2630	590043		-				S/S suction short-elbow
2640	12041		-				F1/4 Ø10 Hose connection

e=ELECTRONICAL SWITCHES, uw=LOWER AND UPPER WASHER

127EU=127EU

A=3/N/PE~380-400V 50-60Hz, D=3/PE~200-210V 50-60Hz, F=2/PE~220-240V 50-60Hz, G=3/N/PE~415V 50-60Hz, H=3/PE~220-230V 50-60Hz, K=3/PE~380-400V 50-60Hz, L=3/PE~415V 50-60Hz, M=3/PE~440V 60Hz, P=1/N/PE~220-230V 50-60Hz, R=2/PE~220-240V 50-60Hz, U=1/N/PE~240V 50-60Hz, V=3/PE~240V 50-60Hz, W=1/N/PE~100-110V 50-60Hz

vsezip.ru

+7(812)987-08-81

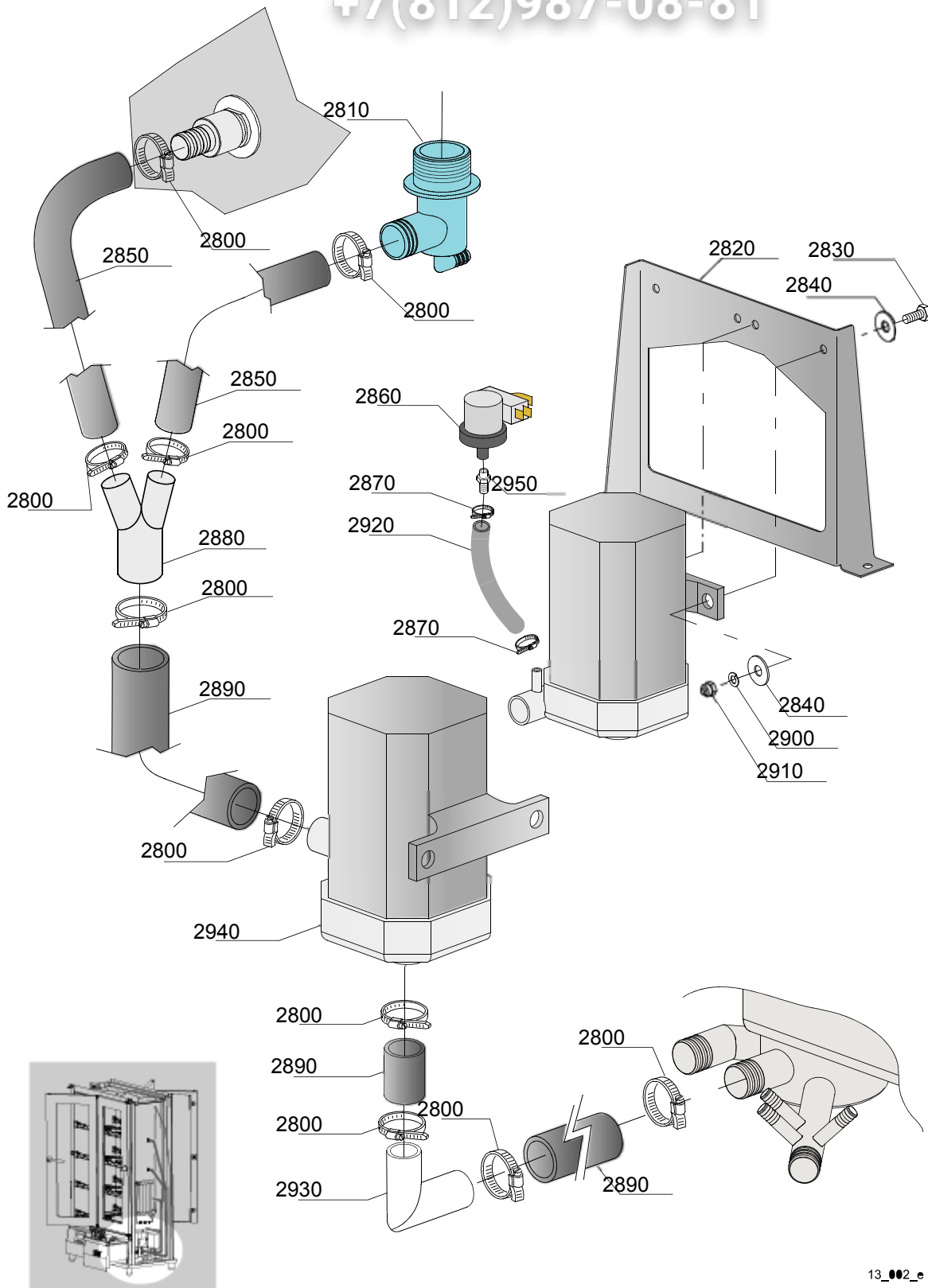

13_002_e

ID	P-code	SN from	SN to	Mod.	Acces.	Volt	Description
Module: Wash pump group							
2800	11806		-				AISI 430 25/40 clamp
2810	590094		-				Tank turret
2820	590048		-				Pumps stand
2830	11104/B		-				S/S screw M6x16 TE
2840	11178		-				S/S washer 6x18
2850	92104		-				Supply hose side arms
2860	3060195		-				Pressure switch
2870	11807		-				AISI 430 12/22 clamp
2880	590045		-				S/S "Y" connection
2890	561067		-				Hose Ø28-26 EPDM
2900	11604		-				S/S grower M6
2910	11706		-				S/S nut M6
2920	14506		-				Rubber hose Ø9,5x16 EPDM
2930	590044		-				S/S suction long-elbow
2940	590046		-				Pump HP0.7 230V.50Hz - external
2950	12041		-				F1/4 Ø10 Hose connection

e=ELECTRONICAL SWITCHES, uw=LOWER AND UPPER WASHER

127EU=127EU

A=3/N/PE~380-400V 50-60Hz, D=3/PE~200-210V 50-60Hz, F=2/PE~220-240V 50-60Hz, G=3/N/PE~415V 50-60Hz, H=3/PE~220-230V 50-60Hz, K=3/PE~380-400V 50-60Hz, L=3/PE~415V 50-60Hz, M=3/PE~440V 60Hz, P=1/N/PE~220-230V 50-60Hz, R=2/PE~220-240V 50-60Hz, U=1/N/PE~240V 50-60Hz, V=3/PE~240V 50-60Hz, W=1/N/PE~100-110V 50-60Hz

vsezip.ru

+7(812)987-08-81

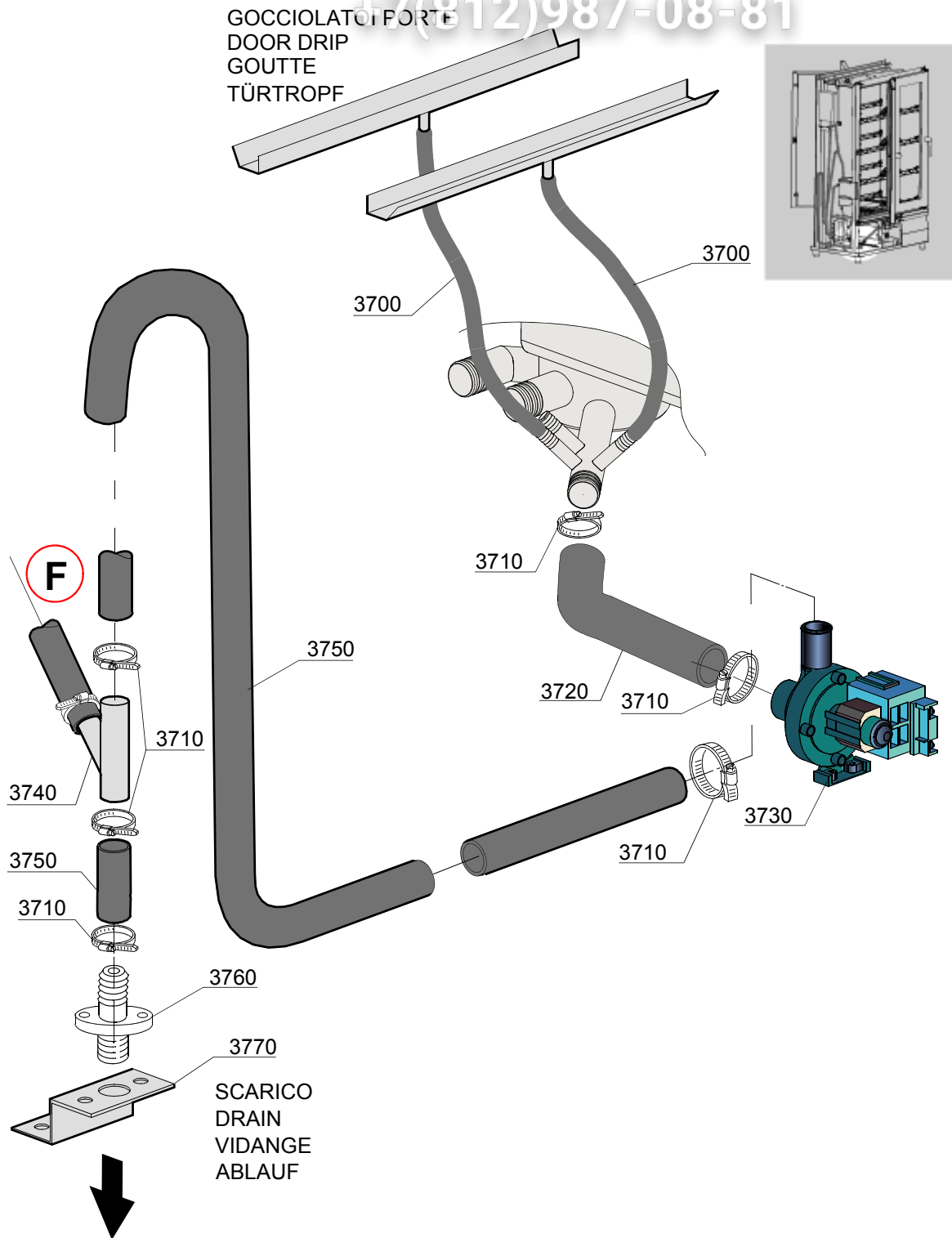

15_001_e

vsezip.ru

ID	P-code	SN from	SN to	Mod	Acces.	Volt	Description
Module: Drain pump group							
3700	14506		-				Rubber hose Ø9,5x16 EPDM
3710	11806		-				AISI 430 25/40 clamp
3720	561067		-				Hose Ø28-26 EPDM (since serial n° DWF1023828)
3720	18044		-				Hose Ø28 EPDM (from serial n° DWG1003423)
3730	15101		-				Drain pump 220/240V 50Hz
3740	590096		-				S/S connection for brine drain
3750	2907357		-				Hose 19x27
3760	540207		-				Drain nipple 20-28
3770	590040		-				Drain nipple basement

e=ELECTRONICAL SWITCHES, uw=LOWER AND UPPER WASHER

127EU=127EU

A=3/N/PE~380-400V 50-60Hz, D=3/PE~200-210V 50-60Hz, F=2/PE~220-240V 50-60Hz, G=3/N/PE~415V 50-60Hz, H=3/PE~220-230V 50-60Hz, K=3/PE~380-400V 50-60Hz, L=3/PE~415V 50-60Hz, M=3/PE~440V 60Hz, P=1/N/PE~220-230V 50-60Hz, R=2/PE~220-240V 50-60Hz, U=1/N/PE~240V 50-60Hz, V=3/PE~240V 50-60Hz, W=1/N/PE~100-110V 50-60Hz

vsezip.ru

+7(812)987-08-81

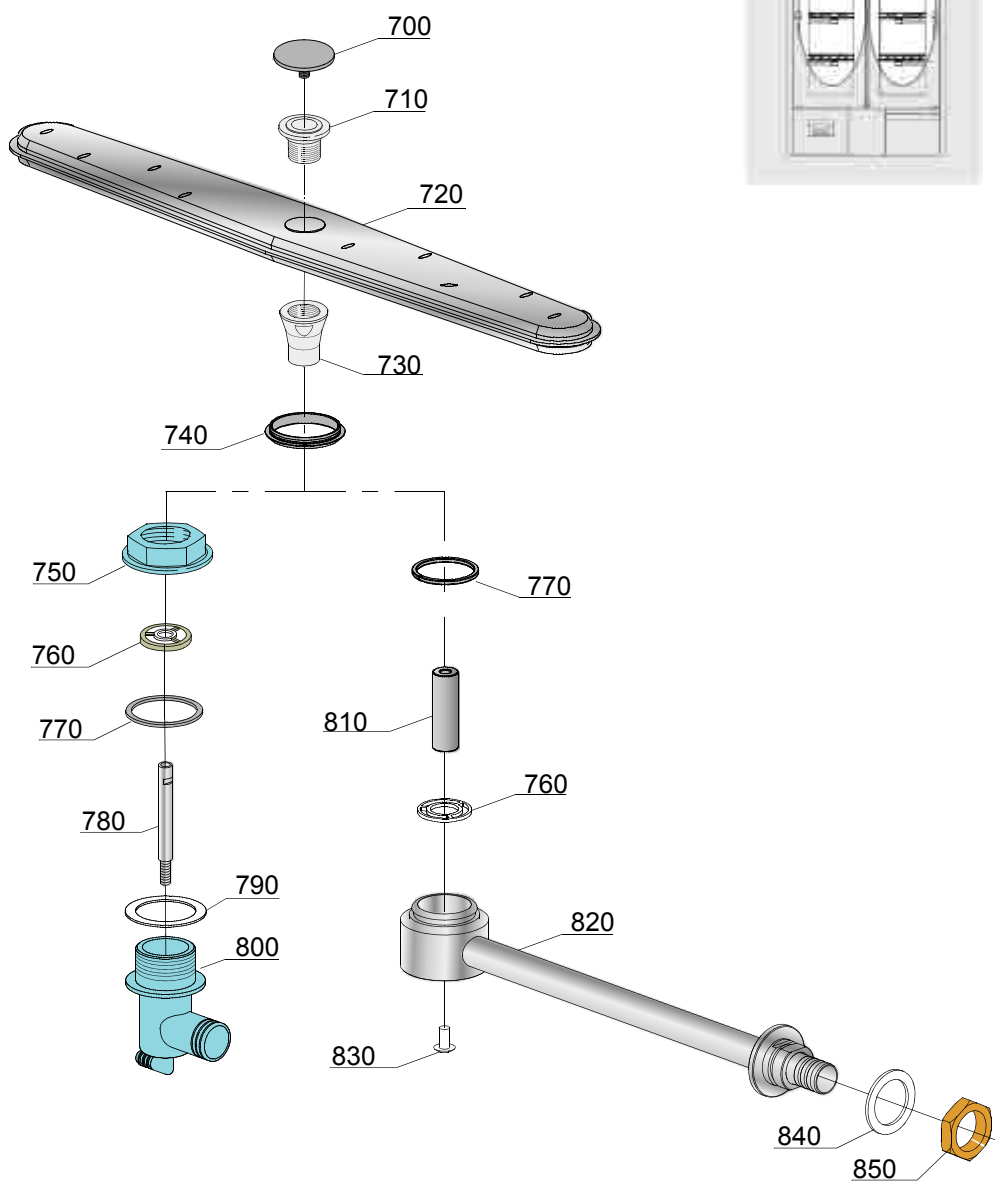

17_001_e

vsezip.ru

ID	P-code	SN from	SN to	Mod	Acces.	Volt	Description
Module:Turret group with rotating arms							
700	11101/A		-				S/S rinse screw Ø30x11 (M8)
710	500701		-				Wash-arm bushing
720	590062		-				S/S wash-arm
730	500702		-				Wash-arm cup
740	590053		-				Wash-arm collar
750	540093		-				Lowered nut
760	540076		-				Centering
770	540079		-				Gasket
780	590061		-				Wash-tank turret shaft
790	540032		-				Gasket
800	590094		-				Wash-tank turret
810	590054		-				Wash-arm support
820	590069		-				Wach-pipe
830	11168		-				S/S screw M6X12
840	13326		-				Gasket
850	2200103		-				Hexagonal brass nut

e=ELECTRONICAL SWITCHES, uw=LOWER AND UPPER WASHER

127EU=127EU

A=3/N/PE~380-400V 50-60Hz, D=3/PE~200-210V 50-60Hz, F=2/PE~220-240V 50-60Hz, G=3/N/PE~415V 50-60Hz, H=3/PE~220-230V 50-60Hz, K=3/PE~380-400V 50-60Hz, L=3/PE~415V 50-60Hz, M=3/PE~440V 60Hz, P=1/N/PE~220-230V 50-60Hz, R=2/PE~220-240V 50-60Hz, U=1/N/PE~240V 50-60Hz, V=3/PE~240V 50-60Hz, W=1/N/PE~100-110V 50-60Hz