

Зип Общепит

vsezip.ru

+7(812)987-08-81

DISHWASHER

ELECTRONICAL SWITCHES
LOWER AND UPPER WASHING
INSULATED MODEL

TYPE: 29ELKC

Accessories
BREAK TANK
BOOSTER PUMP
DVGW
DETERGENT DISPENSER
DRAIN PUMP

Spare Parts Manual

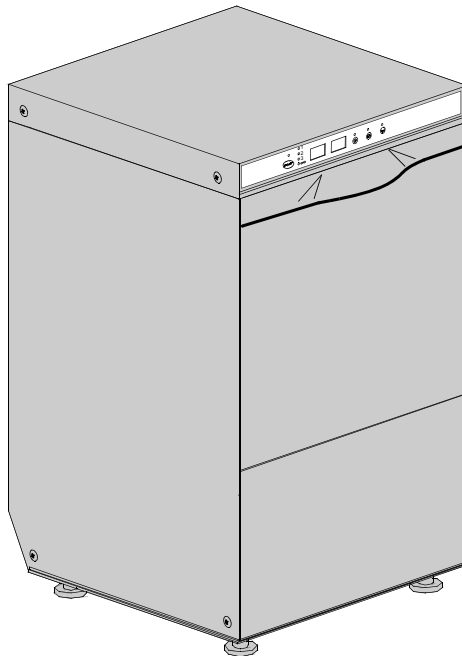

INFORMAZIONI GENERALI

Questo catalogo serve per richiedere con esattezza le parti di ricambio

Nelle ordinazioni indicare:

1) il numero dei codici dei particolari seguito dalla descrizione e la quantità desiderata;

2) Il codice alfa-numerico presente nella seconda colonna della tabella ;

I disegni delle parti di ricambio sono solo indicativi e non rappresentano il pezzo in oggetto.

I dati contenuti in questo catalogo sono indicativi e possono essere soggetti a modifiche senza impegno di preavviso.

ALLGEMEINE INFORMATIONEN

Dieser Ersatzteilkatalog dient zur genauen Angabe der Teile bei Ersatzteilbestellungen.

Bei Ersatzbestellung ist folgendes anzugeben:

1) Die Bestellnummer der Ersatzteile mit der entsprechenden Beschreibung genaue Menge;

2) Der alpha-numerischer Code auf der zweiten Reihe in dein Sculd;

Die Zeichnungen der Ersatzteile sind nur als Hinweise gedacht und stellen nicht das betroffene Teil dar.

Bei den im Katalog angeführten Daten handelt es sich um Anhaltsdaten, die jederzeit, ohne Vorankündigung, geändert werden können.

GENERAL INFORMATION

The present spare parts order exactly the right spare parts

When ordering specify:

1) the part's code number followed by its description and quantity needed;

2) The alpha-numeric code is in the second column in the chart;

Spare parts drawings are general and do not represent the part.

The contents of this catalogue are general and can undergo changes without prior notice.

INFORMACIONES GENERALES

El presente catálogo sirve para pedir con exactitud las partes de repuesto

En los pedidos se debe indicar:

1) el número de código de la parte y a continuación la descripción cantidad deseada;

2) El código alfanumerico presente en la segnada columna de la tabla;

Los diseños de las partes de recambio son solo indicativos y no representan la pieza en cuestión.

Los datos contenidos en el presente catálogo son indicativos y pueden modificarse sin aviso previo.

INFORMATIONS GENERALES

Ce catalogue permet de commander correctement les pièces détachées

Les commandes doivent être passées en indiquant:

1) le numero de code des pièces détachées suivi de leur description quantité désirée;

2) le code alphanumérique dans la deuxième colonne du tableau;

Les plans des pièces détachées sont fournis seulement à titre indicatif et ne représentent pas la pièce concernée.

Les données de ce catalogue sont citées seulement à titre indicatif et peuvent être l'objet de modifications sans avis préalable.

**ESEMPIO
EXAMPLE
EXEMPLE
BEISPIEL**

Rif.	Codici
MODULE:Particolari	
10505	540903
10510	540908
10515	15065/A
10520	540086
10525	540028



Note

Tutte le informazioni riportate si intendono aggiornate alla data di stampa. Il Produttore si riserva il diritto di apportare qualsiasi modifica richiesta dallo sviluppo evolutivo dei suddetti prodotti.

Per la sicurezza, la garanzia, l'affidabilità ed il valore della lavastoviglie usa solo ricambi originali. **Per alcuni codici, sono richieste quantità minime d'ordine.**



Attenzione

Questo libretto è parte integrante della lavastoviglie e, in caso di passaggio di proprietà, deve essere consegnato al nuovo acquirente.



Remarque

Toutes les informations contenues dans ce manuel s'entendent mises à jour à la date d'impression. En raison du développement constant de ses produits, usine se réserve le droit d'apporter à tout instant les modifications qu'elle jugera utiles.

Pour la sécurité, la garantie, la fiabilité et la valeur de votre lavevaisselles n'utilisez que des pièces de rechange d'origine. **Pour quelque référence on demande un minimum de pièces par commande**



Attention

Ce manuel doit être considéré comme partie intégrante de la lavevaisselles, en cas de transfert de propriété, doit toujours être remis au nouveau propriétaire.



Note

The information contained herein is valid at the time of going to print. The Company reserves the right to make any changes required by the future development of the above-mentioned products.

For your safety, as well as to preserve the warranty reliability and worth of your dishwashers, use original spare parts only. **For some codes a minimum quantity for order is required.**



Warning

This manual forms an integral part of the dishwashers and - if a transfer of title occurs - must always be handed over to the new owner.



Hinweis



Die Der Hersteller behält sich das Recht vor, jegliche, durch eine Weiterentwicklung der genannten Produkte bedingte Änderungen vornehmen zu können.

Verwenden Sie für Ihre Sicherheit, die Garantie, die Zuverlässigkeit und den Wert Ihrer machine originale Ersatzteile. **Für bestimmte Code nummer werden mindesten bestellungen verlangt.**



Achtung

Diese Betriebsanleitung ist Bestandteile des machine und muss bei seinem Weiterverkauf dem neuen Besitzer ausgehändigt werden.





+7(812)987-08-81

Code DW 999XXYYYY **CL/Part** 

Model DESCRIPTION
S/N DW A 1015770 Type

400V 3N 50HZ 8A
3500W 500W



IPX3 16A

Pressione Dinamica alimentazione idrica 200-500 kPa
 Pression dynamique arrivée d'eau
 Dynamic pressure water supply
 Dynamischer Druck asserreinlauf

Pressione dinamica vapore saturo
 Pression dynamique vapore satueèè
 Dymanscher Druck gesattigter Dampf
 Pression Dinamica Vapor Saturado

TECHICAL SPECIFICATION



MADE IN ITALY

Temperatura massima acqua in ingresso 60°C
 Temperature max eau a l'entre
 Maximale Temperatur Wasseranschlü
 Maximum Water temperature in-feeding

Model 

S/N 

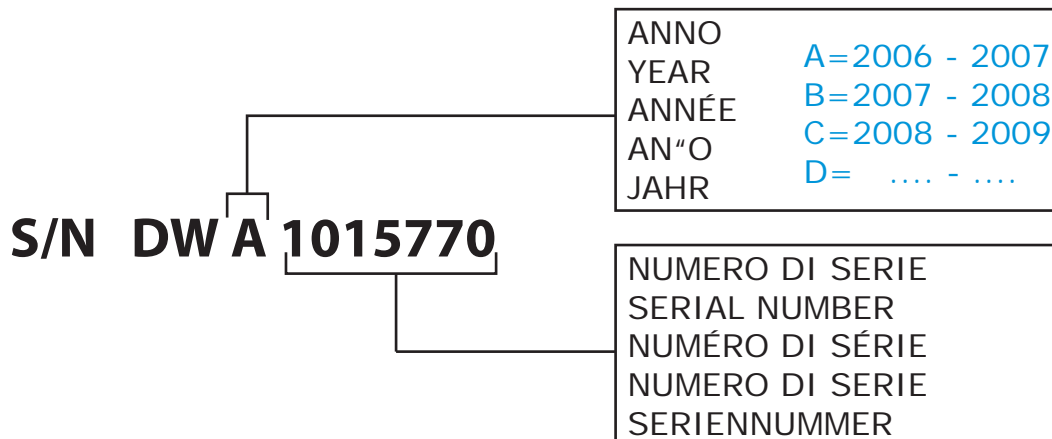
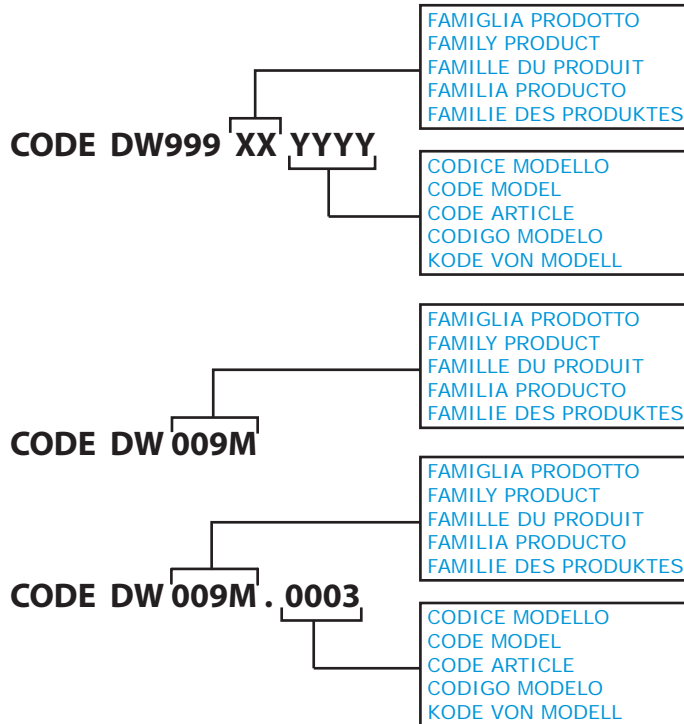

Spare parts

Зип Общепит

vsezip.ru

+7(812)987-08-81

vsezip.ru

+7(812)987-08-81

1. Spare parts

General body parts.....	7
Lockup system	9
Electric control components.....	11
Command electronic control	13
Solenoid valve group	15
Break Tank	17
Booster pump.....	19
DVGW	21
Rinse aid dispenser group.....	23
Rinse aid dispenser group.....	25
Boiler group	27
3 ways connection	29
Wash pump	31
Dosing detergent group.....	33
Drain pump group.....	35
Pressure switch group with air trap ...	37

Turret group with rotating arms39

+7(812)987-08-81

1.1 Voltage codes

Volt	Voltage code
A	3/N/PE~380-400V 50-60Hz
D	3/PE~200-210V 50-60Hz
F	2/PE~220-240V 50-60Hz
G	3/N/PE~415V 50-60Hz
H	3/PE~220-230V 50-60Hz
K	3/PE~380-400V 50-60Hz
L	3/PE~415V 50-60Hz
M	3/PE~440V 60Hz
P	1/N/PE~220-230V 50-60Hz
R	2/PE~220-240V 50-60Hz
U	1/N/PE~240V 50-60Hz
V	3/PE~240V 50-60Hz
W	1/N/PE~100-110V 50-60Hz

1.2 Product codes

Product code	Full name
Model codes	
e	ELECTRONICAL SWITCHES
uw	LOWER AND UPPER WASHING
i	INSULATED MODEL
Type codes	
29ELKC	29ELKC
Accessory codes	
bt	BREAK TANK
bp	BOOSTER PUMP
dvgw	DVGW
dd	DETERGENT DISPENSER
dp	DRAIN PUMP

vsezip.ru

+7(812)987-08-81

01_002ae

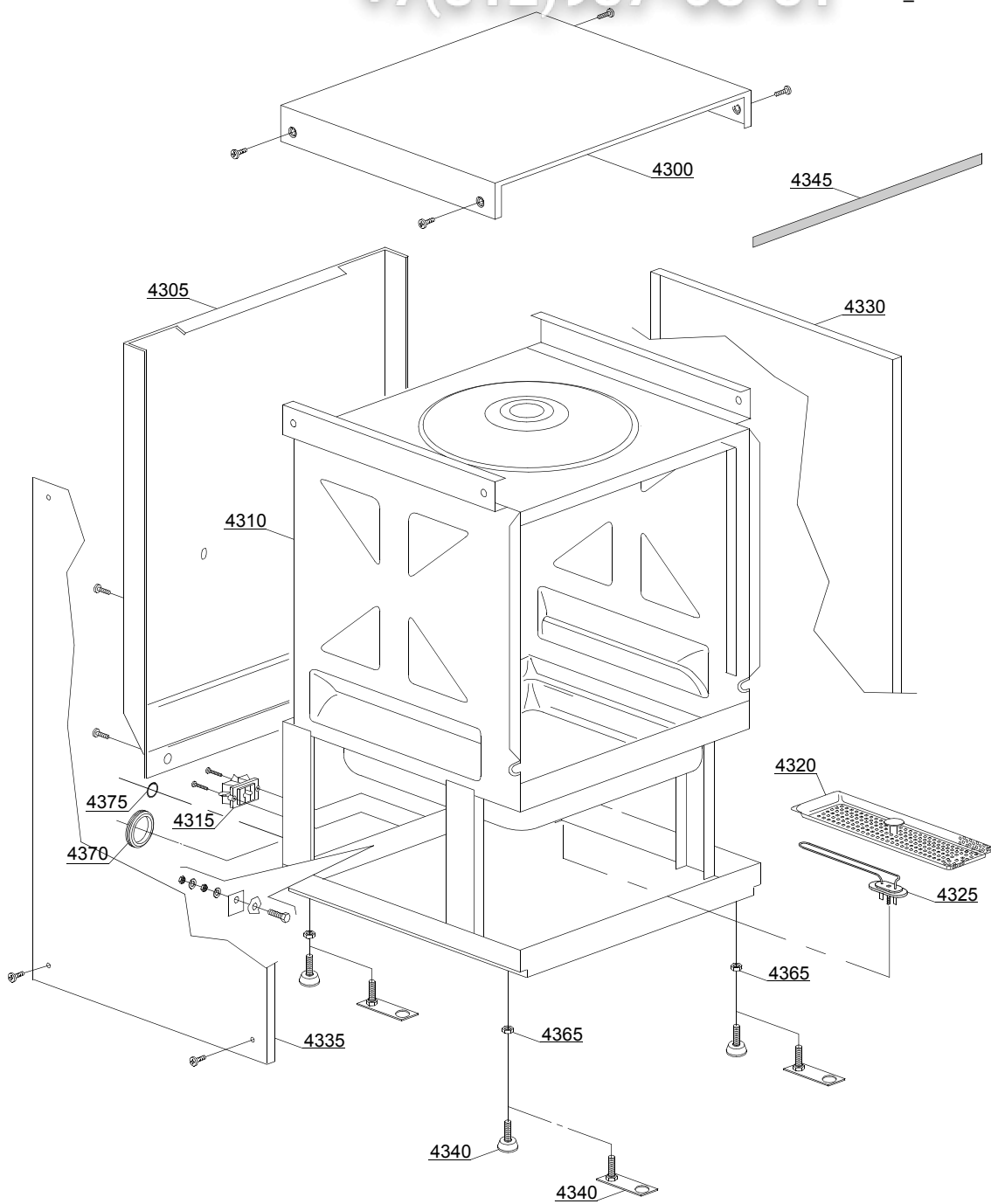

vsezip.ru

ID	P-code	SN from	SN to	Mod	Acces.	Volt	Description
Module:General body parts							
4300	560917		-	i,e			Cover
4305	560919		-	i,e			Back panel
4305	560938		-	i,e	bt		Back panel
4315	15065/A		-	i,e			Cable-fastener with screw
4320	561009		-	i,e			Surface filter
4325	540406		-	i,e			0,4/0,44KW 230/240V heating element
4330	560914		-	i,e			Right side
4335	560915		-	i,e			Left side
4340	10786		-	i,e			M10x25 Ø40 black foot (minimum 4 pieces)
4340	15176		-	i,e			M10 marina foot
4345	560021		-	i,e			Profile for door O-ring
4365	11711		-	i,e			M10 zinc plated nut (minimum 20 pieces)
4370	13317		-	i,e			D.40mm unloading pipe pass (minimum 2 pieces)
4375	13323		-	i,e			D.13mm dosing pipe pass (minimum 2 pieces)

e=ELECTRONICAL SWITCHES, uw=LOWER AND UPPER WASHING, i=INSULATED MODEL

29ELKC=29ELKC

bt=BREAK TANK, bp=BOOSTER PUMP, dvgw=DVGW, dd=DETERGENT DISPENSER, dp=DRAIN PUMP

A=3/N/PE~380-400V 50-60Hz, D=3/PE~200-210V 50-60Hz, F=2/PE~220-240V 50-60Hz, G=3/N/PE~415V 50-60Hz, H=3/PE~220-230V 50-60Hz, K=3/PE~380-400V 50-60Hz, L=3/PE~415V 50-60Hz, M=3/PE~440V 60Hz, P=1/N/PE~220-230V 50-60Hz, R=2/PE~220-240V 50-60Hz, U=1/N/PE~240V 50-60Hz, V=3/PE~240V 50-60Hz, W=1/N/PE~100-110V 50-60Hz

vsezip.ru

+7(812)987-08-81

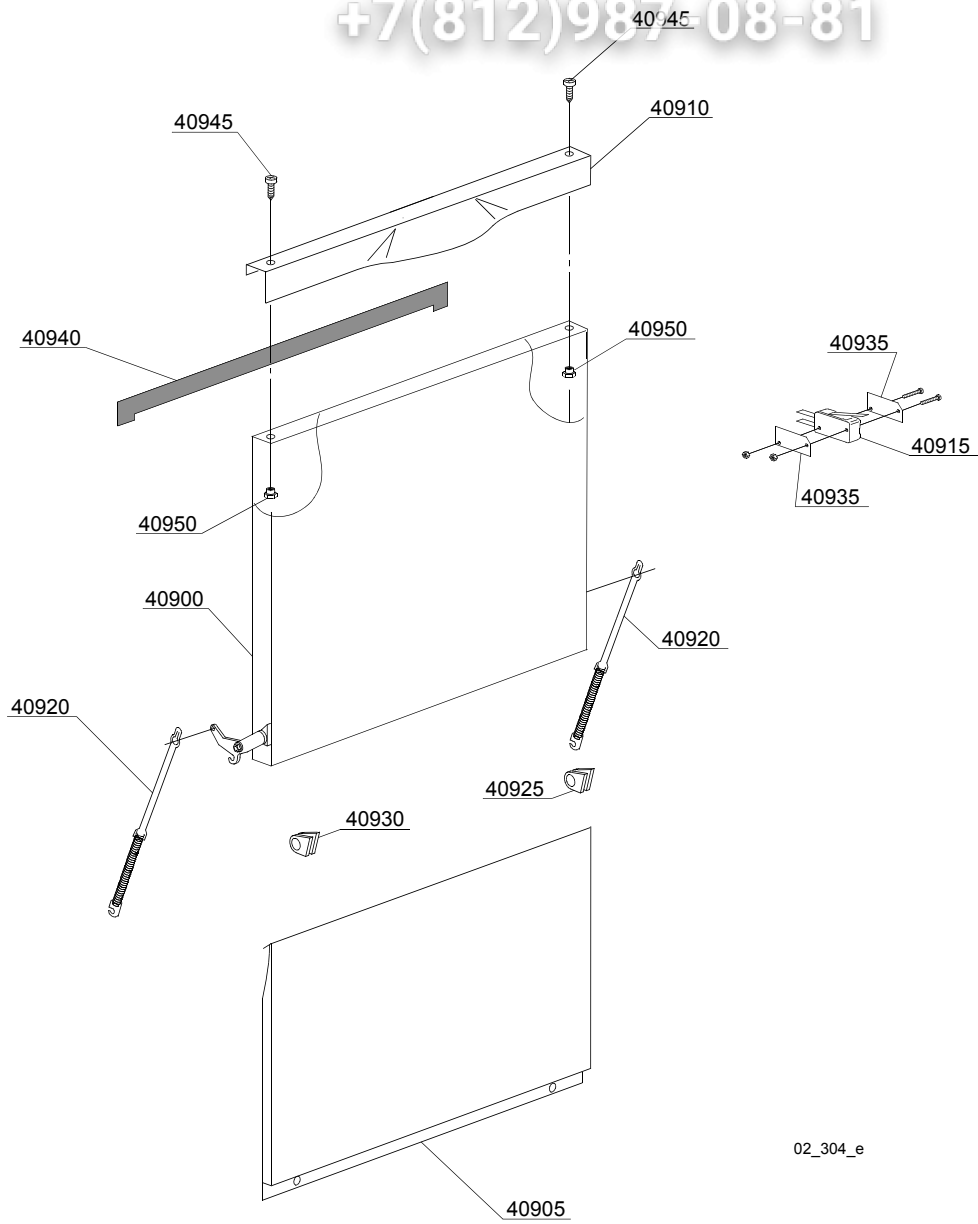

02_304_e

ID	P-code	SN from	SN to	Mod	Acces.	Volt	Description
Module: Lockup system							
40900	560963		-				Door with steel handle
40905	560920		-				Lower door
40910	560959		-				Stainless steel handle
40915	10704		-				Door microswitch
40920	560003		-				Door spring
40925	560006		-				Right lock for door hinge (minimum 2 pieces)
40930	560007		-				Left lock for door hinge (minimum 2 pieces)
40935	10770		-				Insulation for door microswitch (minimum 3 pieces)
40940	560021		-				Profile for door O-ring
40945	11225		-				M4x6 Inox Screw
40950	11226		-				M4 inox Plated nut

e=ELECTRONICAL SWITCHES, uw=LOWER AND UPPER WASHING, i=INSULATED MODEL

29ELKC=29ELKC

bt=BREAK TANK, bp=BOOSTER PUMP, dvgw=DVGW, dd=DETERGENT DISPENSER, dp=DRAIN PUMP

A=3/N/PE~380-400V 50-60Hz, D=3/PE~200-210V 50-60Hz, F=2/PE~220-240V 50-60Hz, G=3/N/PE~415V 50-60Hz, H=3/PE~220-230V 50-60Hz, K=3/PE~380-400V 50-60Hz, L=3/PE~415V 50-60Hz, M=3/PE~440V 60Hz, P=1/N/PE~220-230V 50-60Hz, R=2/PE~220-240V 50-60Hz, U=1/N/PE~240V 50-60Hz, V=3/PE~240V 50-60Hz, W=1/N/PE~100-110V 50-60Hz

vsezip.ru

+7(812)987-08-81

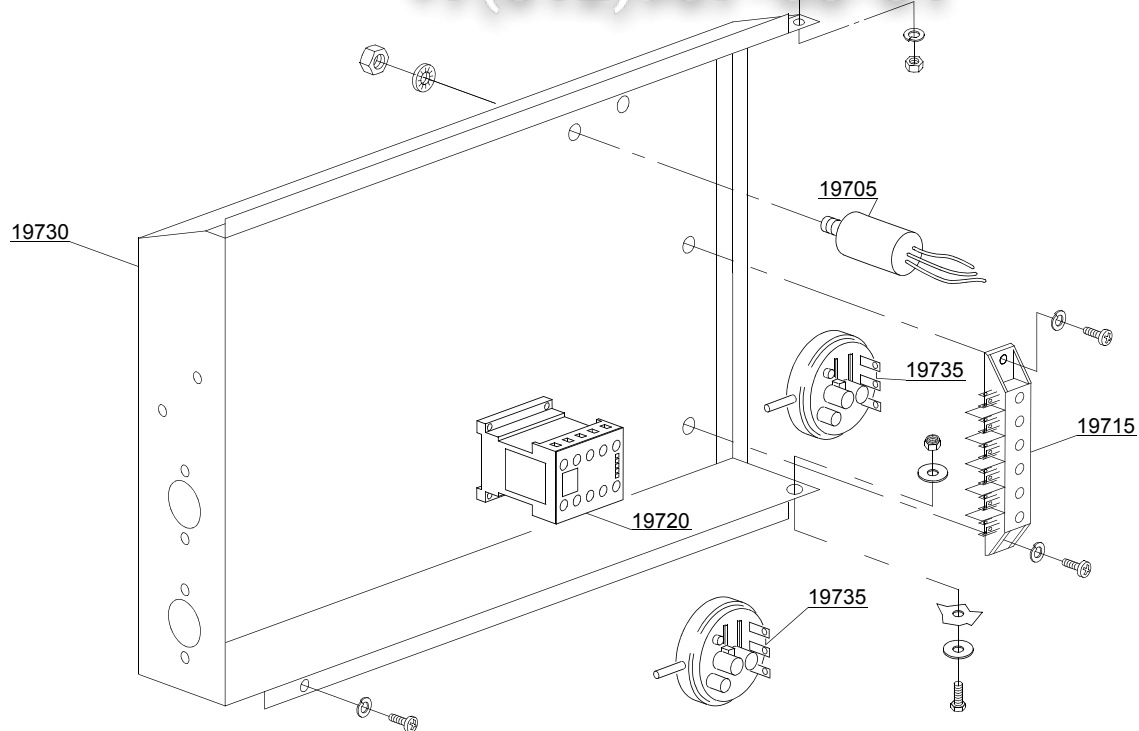

04_019ae

vsezip.ru

ID	P-code	SN from	SN to	Mod.	Acces.	Volt	Description
Module: Electric control components							
19705	15149		-	i,e			Low noise filter
19715	500551		-	i,e			6 poles terminal board
19720	15086		-	i,e			Contactactor 230V 50/60Hz 4C
19720	15086/B		-	i,e			Contactactor 240V 50Hz
19730	560921		-	i,e			Electric components panel
19735	10300026		-	i,e			76-38 pressure switch
19735	80225		-	i,e			18-100 pressure switch

e=ELECTRONICAL SWITCHES, uw=LOWER AND UPPER WASHING, i=INSULATED MODEL

29ELKC=29ELKC

bt=BREAK TANK, bp=BOOSTER PUMP, dvgw=DVGW, dd=DETERGENT DISPENSER, dp=DRAIN PUMP

A=3/N/PE~380-400V 50-60Hz, D=3/PE~200-210V 50-60Hz, F=2/PE~220-240V 50-60Hz, G=3/N/PE~415V 50-60Hz, H=3/PE~220-230V 50-60Hz, K=3/PE~380-400V 50-60Hz, L=3/PE~415V 50-60Hz, M=3/PE~440V 60Hz, P=1/N/PE~220-230V 50-60Hz, R=2/PE~220-240V 50-60Hz, U=1/N/PE~240V 50-60Hz, V=3/PE~240V 50-60Hz, W=1/N/PE~100-110V 50-60Hz

vsezip.ru

+7(812)987-08-81

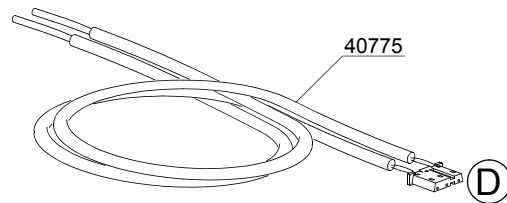
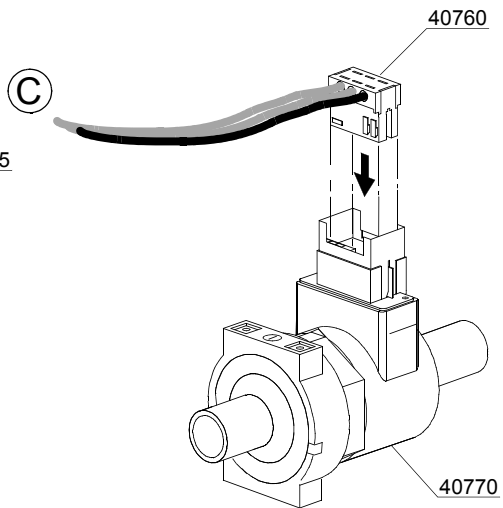
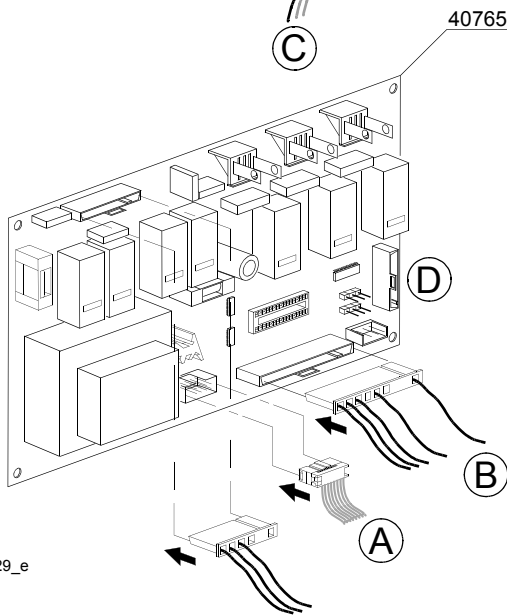
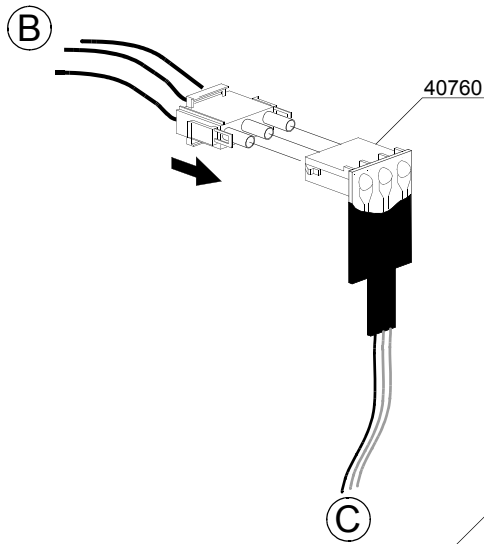
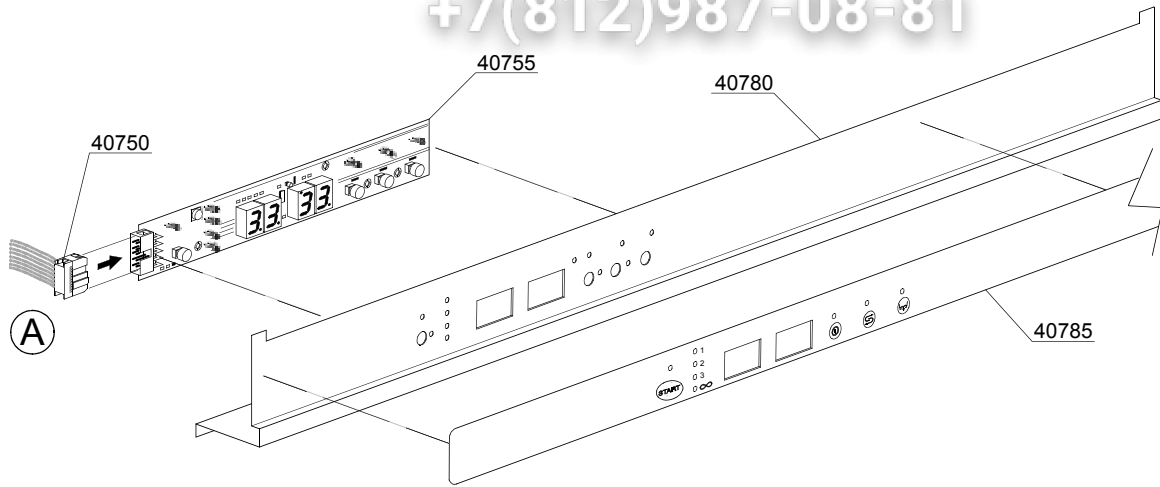

04_029_e

vsezip.ru

ID	P-code	SN from	SN to	Mod.	Acces.	Volt	Description
Module:Command electronic control							
40750	50582		-	i,e			Plug L=2300mm
40750	50589		-	i,e			Plug L=500mm
40755	50581		-	i,e			Touche sensitive
40760	50584		-	i,e			Water flow board
40765	50580		-	i,e			Electronic timer+main board
40765	50590		-	i,e			Electronic timer+main board BA
40770	50583		-	i,e			Water flow meter for board
40775	50562		-	i,e			Temperature probe set
40780	560964		-	i,e			Control Panel
40785	560039		-	i,e			Neutral-full Silkscreen processed grill

e=ELECTRONICAL SWITCHES, uw=LOWER AND UPPER WASHING, i=INSULATED MODEL

29ELKC=29ELKC

bt=BREAK TANK, bp=BOOSTER PUMP, dvgw=DVGW, dd=DETERGENT DISPENSER, dp=DRAIN PUMP

A=3/N/PE~380-400V 50-60Hz, D=3/PE~200-210V 50-60Hz, F=2/PE~220-240V 50-60Hz, G=3/N/PE~415V 50-60Hz, H=3/PE~220-230V 50-60Hz, K=3/PE~380-400V 50-60Hz, L=3/PE~415V 50-60Hz, M=3/PE~440V 60Hz, P=1/N/PE~220-230V 50-60Hz, R=2/PE~220-240V 50-60Hz, U=1/N/PE~240V 50-60Hz, V=3/PE~240V 50-60Hz, W=1/N/PE~100-110V 50-60Hz

vsezip.ru

+7(812)987-08-81

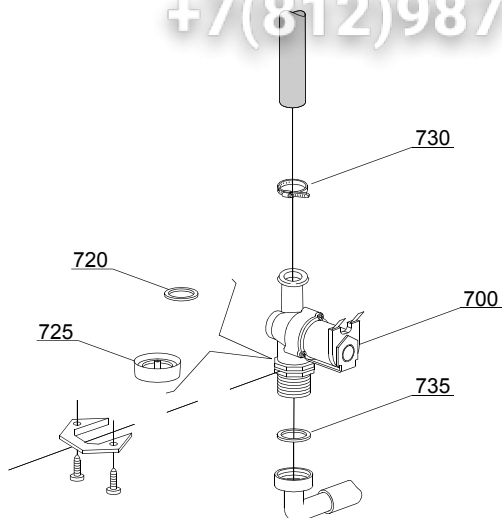

05_002_e

vsezip.ru

ID	P-code	SN from	SN to	Mod.	Acces.	Volt	Description
Module:Solenoid valve group							
700	10703		-	i,e			Single solenoid valve - 230Vac
720	N.C.		-	i,e			Pression reducing valve
730	11807		-	i,e			12/22 clamp (minimum 3 pieces)
735	13307		-	i,e			3/4 gasket

e=ELECTRONICAL SWITCHES, uw=LOWER AND UPPER WASHING, i=INSULATED MODEL

29ELKC=29ELKC

bt=BREAK TANK, bp=BOOSTER PUMP, dvgw=DVGW, dd=DETERGENT DISPENSER, dp=DRAIN PUMP

A=3/N/PE~380-400V 50-60Hz, D=3/PE~200-210V 50-60Hz, F=2/PE~220-240V 50-60Hz, G=3/N/PE~415V 50-60Hz, H=3/PE~220-230V 50-60Hz, K=3/PE~380-400V 50-60Hz, L=3/PE~415V 50-60Hz, M=3/PE~440V 60Hz, P=1/N/PE~220-230V 50-60Hz, R=2/PE~220-240V 50-60Hz, U=1/N/PE~240V 50-60Hz, V=3/PE~240V 50-60Hz, W=1/N/PE~100-110V 50-60Hz

vsezip.ru

+7(812)987-08-81

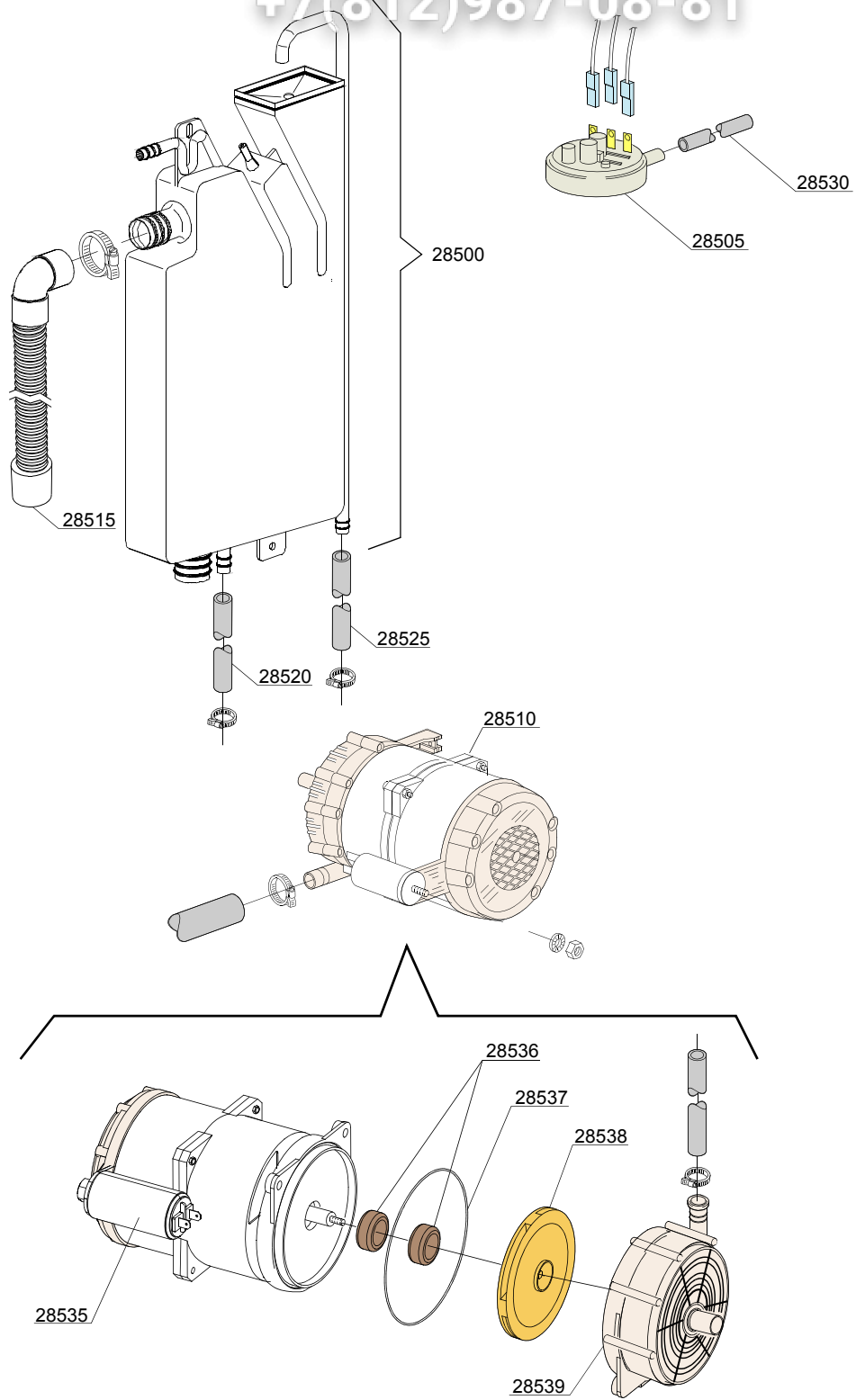

06_004ae

vsezip.ru

ID	P-code	SN from	SN to	Mod.	Acces.	Volt	Description
Module:Break Tank							
28500	15735		-	e,i	bt		Break tank assembly
28505	10706/A		-	e,i	bt		47-27 pressure switch
28510	15100/D		-	e,i	bt		Booster pump 220/240V - body pumps in plastic
28515	15721		-	e,i	bt		BT long pipe L=1070
28515	15722		-	e,i	bt		BT middle pipe L=920
28515	15723		-	e,i	bt		BT small pipe L=690
28520	2907350		-	e,i	bt		12x20 EPDM rubber hose
28525	2907352		-	e,i	bt		PVC WRAS rubber hose
28530	14508		-	e,i	bt		4,5x9 EPDM rubber hose (minimum 2 mt)
28535	10702		-	e,i	bt		5 uF condenser - 450V
28536	15100/S		-	e,i	bt		Rotating seals
28537	15100/T		-	e,i	bt		OR-(O-ring) gasket EPDM
28538	15100/U		-	e,i	bt		Pump rotor
28539	15100/V		-	e,i	bt		Scroll

e=ELECTRONICAL SWITCHES, uw=LOWER AND UPPER WASHING, i=INSULATED MODEL

29ELKC=29ELKC

bt=BREAK TANK, bp=BOOSTER PUMP, dvgw=DVGW, dd=DETERGENT DISPENSER, dp=DRAIN PUMP

A=3/N/PE~380-400V 50-60Hz, D=3/PE~200-210V 50-60Hz, F=2/PE~220-240V 50-60Hz, G=3/N/PE~415V 50-60Hz, H=3/PE~220-230V 50-60Hz, K=3/PE~380-400V 50-60Hz, L=3/PE~415V 50-60Hz, M=3/PE~440V 60Hz, P=1/N/PE~220-230V 50-60Hz, R=2/PE~220-240V 50-60Hz, U=1/N/PE~240V 50-60Hz, V=3/PE~240V 50-60Hz, W=1/N/PE~100-110V 50-60Hz

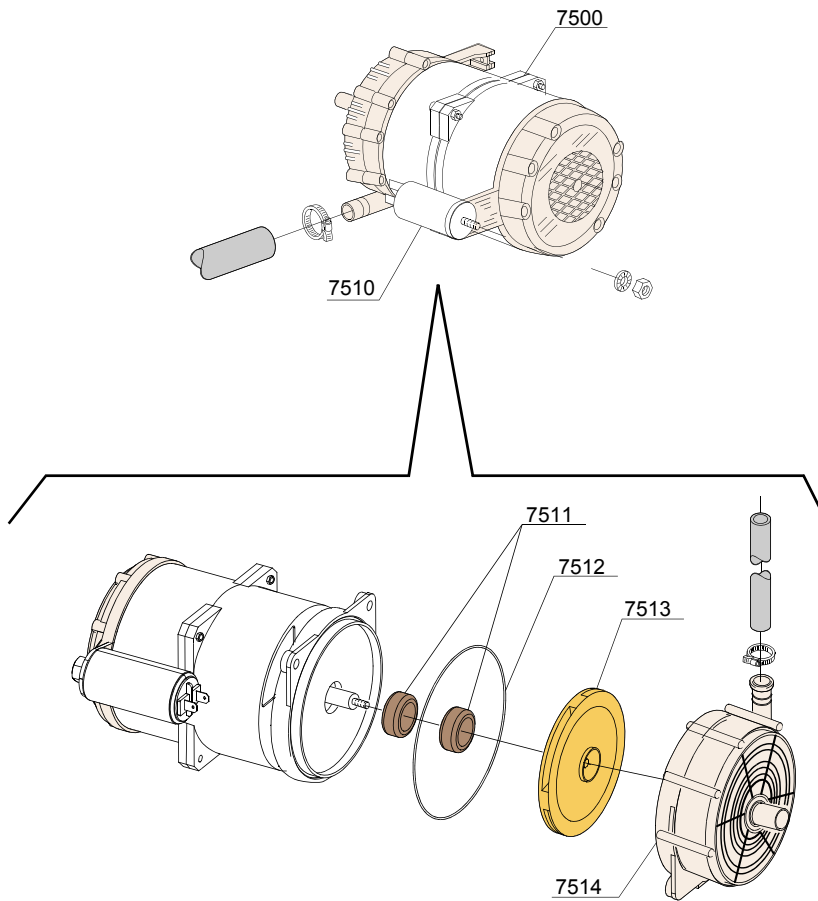

VERSIONE BREAK TANK / VERSIONE PLUS
BREAK TANK VERSION / SYSTEM PLUS VERSION
VERSION BREAK TANK / VERSION SISTEME PLUS

vsezip.ru

ID	P-code	SN from	SN to	Mod.	Acces.	Volt	Description
Module:Booster pump							
7500	15100/D		-	e,i	bp		Booster pump 220/240V - body pumps in plastic
7505	12013		-	e,i	bp		Rubber-holder
7510	10702		-	e,i	bp		5 uF condenser - 450V
7511	15100/S			e,i	bp		Rotating seals
7512	15100/T			e,i	bp		OR (O-ring) gasket EPDM
7513	15100/U			e,i	bp		Pump rotor
7514	15100/V			e,i	bp		Scroll

e=ELECTRONICAL SWITCHES, uw=LOWER AND UPPER WASHING, i=INSULATED MODEL

29ELKC=29ELKC

bt=BREAK TANK, bp=BOOSTER PUMP, dvgw=DVGW, dd=DETERGENT DISPENSER, dp=DRAIN PUMP

A=3/N/PE~380-400V 50-60Hz, D=3/PE~200-210V 50-60Hz, F=2/PE~220-240V 50-60Hz, G=3/N/PE~415V 50-60Hz, H=3/PE~220-230V 50-60Hz, K=3/PE~380-400V 50-60Hz, L=3/PE~415V 50-60Hz, M=3/PE~440V 60Hz, P=1/N/PE~220-230V 50-60Hz, R=2/PE~220-240V 50-60Hz, U=1/N/PE~240V 50-60Hz, V=3/PE~240V 50-60Hz, W=1/N/PE~100-110V 50-60Hz

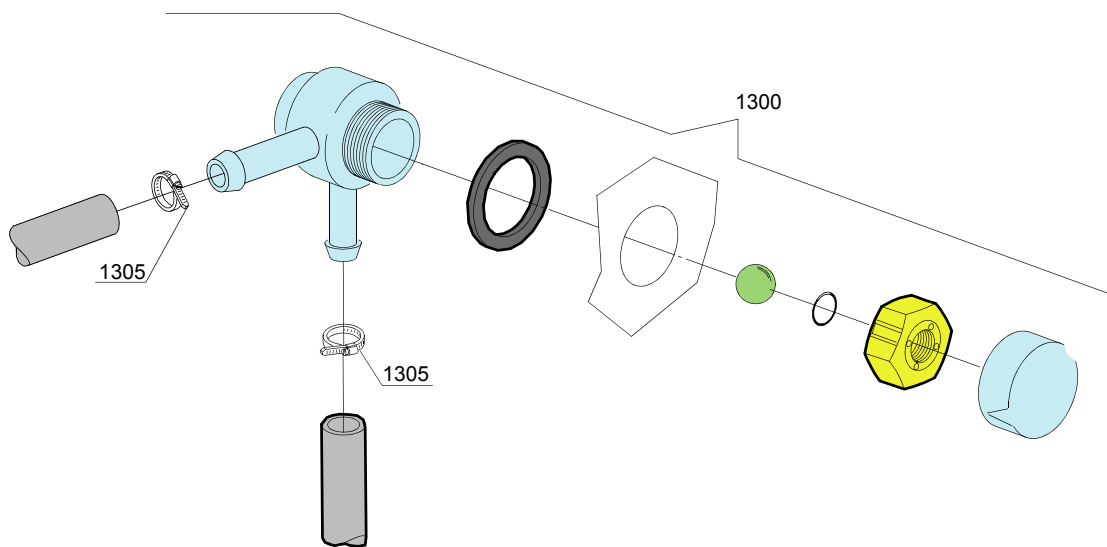

vsezip.ru

ID	P-code	SN from	SN to	Mod.	Acces.	Volt	Description
Module: DVGW							
1300	999900006		-	e,i	dvgw		DVGW assembly
1305	11807		-	e,i	dvgw		12/22 clamp (minimum 3 pieces)

e=ELECTRONICAL SWITCHES, uw=LOWER AND UPPER WASHING, i=INSULATED MODEL

29ELKC=29ELKC

bt=BREAK TANK, bp=BOOSTER PUMP, dvgw=DVGW, dd=DETERGENT DISPENSER, dp=DRAIN PUMP

A=3/N/PE~380-400V 50-60Hz, D=3/PE~200-210V 50-60Hz, F=2/PE~220-240V 50-60Hz, G=3/N/PE~415V 50-60Hz, H=3/PE~220-230V 50-60Hz, K=3/PE~380-400V 50-60Hz, L=3/PE~415V 50-60Hz, M=3/PE~440V 60Hz, P=1/N/PE~220-230V 50-60Hz, R=2/PE~220-240V 50-60Hz, U=1/N/PE~240V 50-60Hz, V=3/PE~240V 50-60Hz, W=1/N/PE~100-110V 50-60Hz

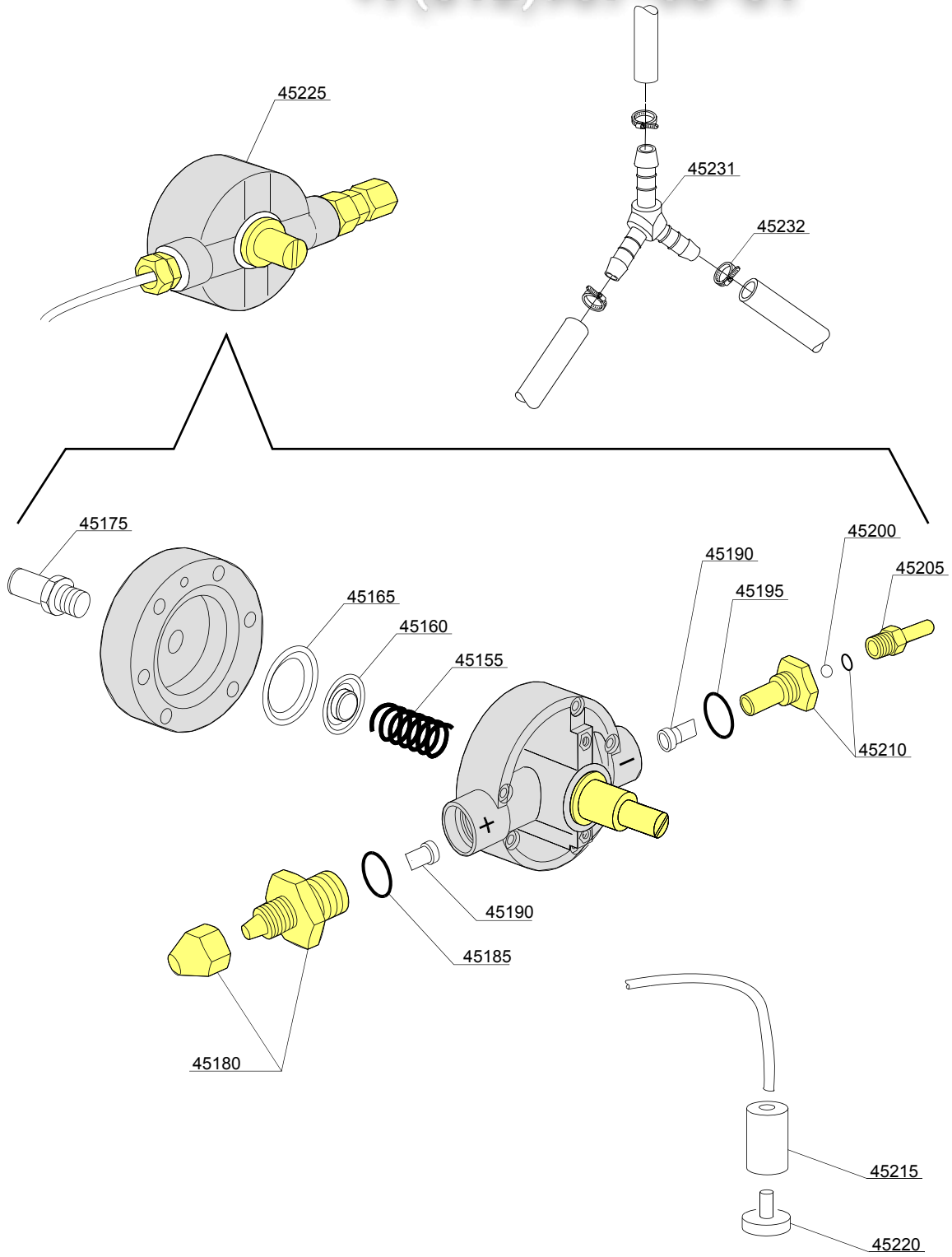

ID	P-code	SN from	SN to	Mod.	Acces.	Volt	Description
Module: Rinse aid dispenser group							
45155	10705/M		-	e,i			Spring
45160	10705/N		-	e,i			Disc to membrane
45165	10750/O		-	e,i			Membrane
45175	12506		-	e,i			Rubber-holder Ø 10mm
45180	10705/G		-	e,i			Pipe fitting
45185	10705/C		-	e,i			OR-gasket
45190	10705/D		-	e,i			Silicone valve
45195	10705/C		-	e,i			OR-gasket
45200	10705/T		-	e,i			Sphere made of Teflon
45205	10705/R		-	e,i			Brass pipe fitting
45210	10705/E		-	e,i			OR-gasket Guide valve
45215	12525		-	e,i			Ballast
45220	15058		-	e,i			Small filter (minimum 3 pieces)
45225	10799/G		-	e,i			GERMAC rinse aid dispenser
45231	540091		-	e,i			Ø12 mm plastic 3 ways connection
45232	11807		-	e,i			Clamp 12-22 (minimum 3 pieces)

e=ELECTRONICAL SWITCHES, uw=LOWER AND UPPER WASHING, i=INSULATED MODEL

29ELKC=29ELKC

bt=BREAK TANK, bp=BOOSTER PUMP, dvgw=DVGW, dd=DETERGENT DISPENSER, dp=DRAIN PUMP

A=3/N/PE~380-400V 50-60Hz, D=3/PE~200-210V 50-60Hz, F=2/PE~220-240V 50-60Hz, G=3/N/PE~415V 50-60Hz, H=3/PE~220-230V 50-60Hz, K=3/PE~380-400V 50-60Hz, L=3/PE~415V 50-60Hz, M=3/PE~440V 60Hz, P=1/N/PE~220-230V 50-60Hz, R=2/PE~220-240V 50-60Hz, U=1/N/PE~240V 50-60Hz, V=3/PE~240V 50-60Hz, W=1/N/PE~100-110V 50-60Hz

vsezip.ru

+7(812)987-08-81

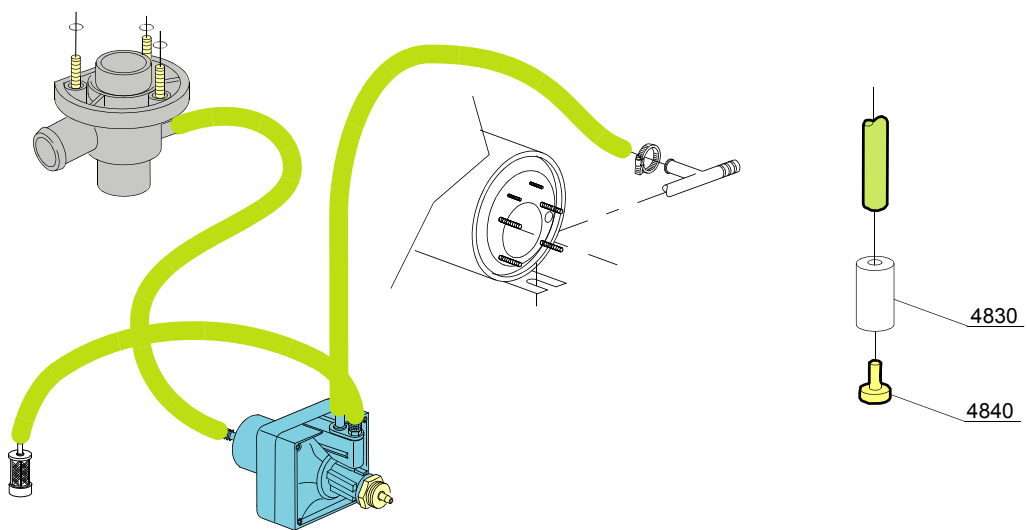
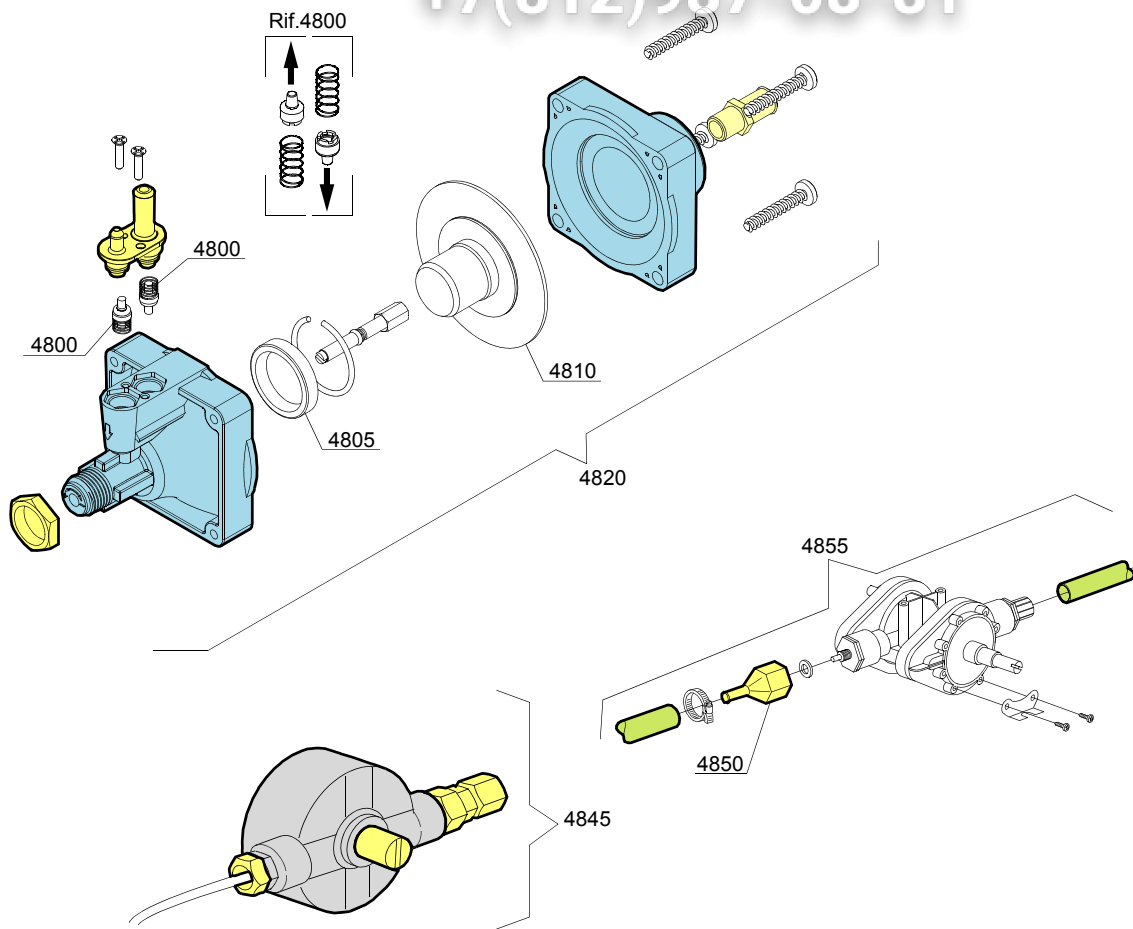

10_004_e

vsezip.ru

ID	P-code	SN from	SN to	Mod	Acces	Volt	Description
Module: Rinse aid dispenser group							
4800	10805		-	e			Tecnopro non return valve
4805	10806		-	e			Ø22 O-ring
4810	10807		-	e			Membrane
4820	10799		-	e			TECNO PRO rinse aid dispenser
4830	12525		-	e			Ballast
4840	15058		-	e			Small filter (minimum 3 pieces)
4845	10799		-	e			GERMAC rinse aid dispenser
4850	10798/B		-	e			Brass pipe fitting
4855	10798		-	e			LANG rinse aid dispenser

e=ELECTRONICAL SWITCHES, uw=LOWER AND UPPER WASHING, i=INSULATED MODEL

29ELKC=29ELKC

bt=BREAK TANK, bp=BOOSTER PUMP, dvgw=DVGW, dd=DETERGENT DISPENSER, dp=DRAIN PUMP

A=3/N/PE~380-400V 50-60Hz, D=3/PE~200-210V 50-60Hz, F=2/PE~220-240V 50-60Hz, G=3/N/PE~415V 50-60Hz, H=3/PE~220-230V 50-60Hz, K=3/PE~380-400V 50-60Hz, L=3/PE~415V 50-60Hz, M=3/PE~440V 60Hz, P=1/N/PE~220-230V 50-60Hz, R=2/PE~220-240V 50-60Hz, U=1/N/PE~240V 50-60Hz, V=3/PE~240V 50-60Hz, W=1/N/PE~100-110V 50-60Hz

vsezip.ru

+7(812)987-08-81

11_002_e

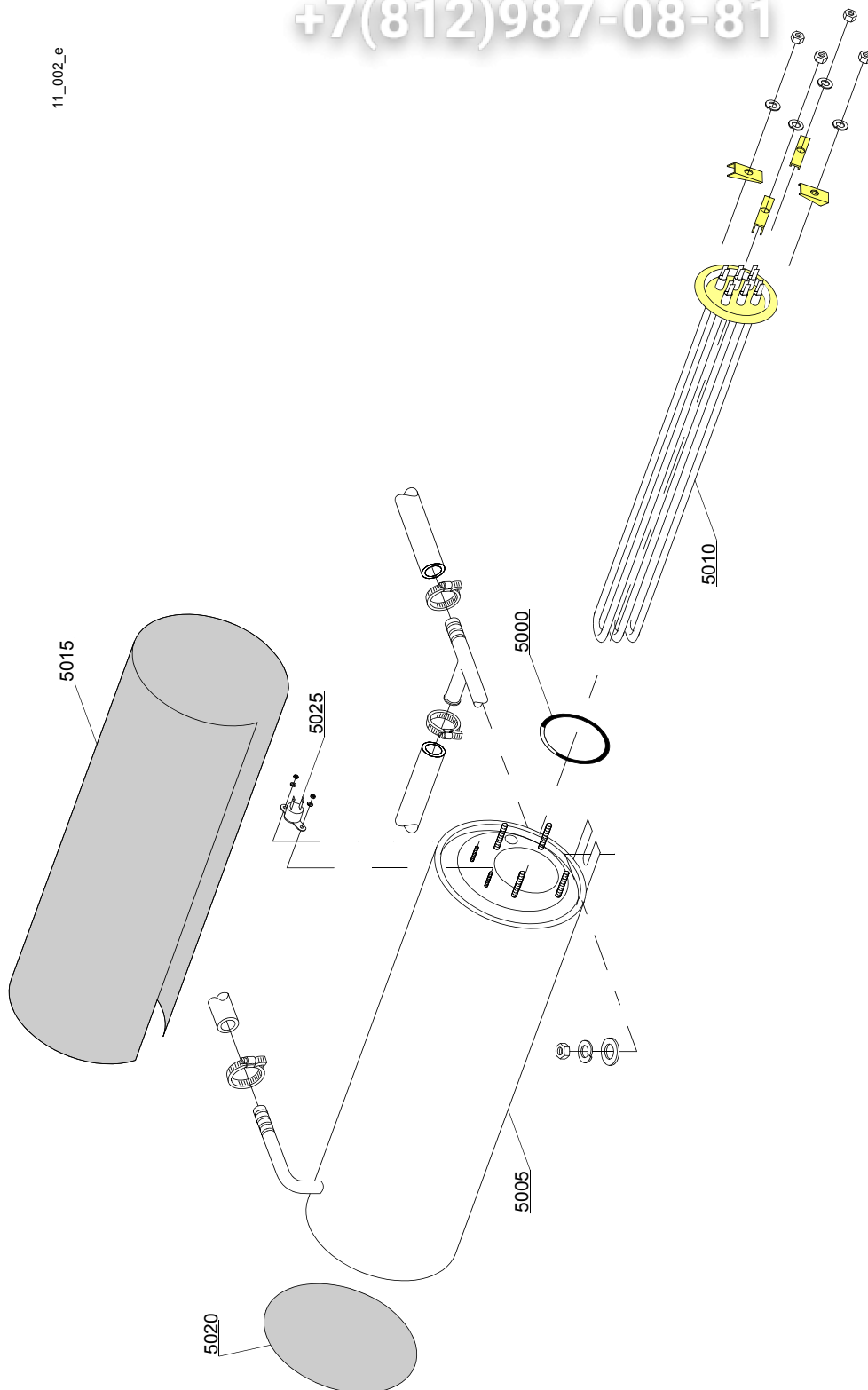

vsezip.ru

ID	P-code	SN from	SN to	Mod.	Acces	Volt	Description
Module:Boiler group							
5000	13005		-	e,i			OR 151 NBR O-ring (minimum 5 pieces)
5005	150905		-	e,i			Boiler
5010	15089		-	e,i			4,5/4,9KW 230/240V 3 heating element
5010	15089/E		-	e,i			6/6,53KW - 230/240V 3 heating element
5015	15066		-	e,i			Insulation boiler
5020	15205		-	e,i			Ø160 End piece (minimum 2 pieces)
5025	15550		-	e,i			Safety thermostat

e=ELECTRONICAL SWITCHES, uw=LOWER AND UPPER WASHING, i=INSULATED MODEL

29ELKC=29ELKC

bt=BREAK TANK, bp=BOOSTER PUMP, dvgw=DVGW, dd=DETERGENT DISPENSER, dp=DRAIN PUMP

A=3/N/PE~380-400V 50-60Hz, D=3/PE~200-210V 50-60Hz, F=2/PE~220-240V 50-60Hz, G=3/N/PE~415V 50-60Hz, H=3/PE~220-230V 50-60Hz, K=3/PE~380-400V 50-60Hz, L=3/PE~415V 50-60Hz, M=3/PE~440V 60Hz, P=1/N/PE~220-230V 50-60Hz, R=2/PE~220-240V 50-60Hz, U=1/N/PE~240V 50-60Hz, V=3/PE~240V 50-60Hz, W=1/N/PE~100-110V 50-60Hz

vsezip.ru

+7(812)987-08-81

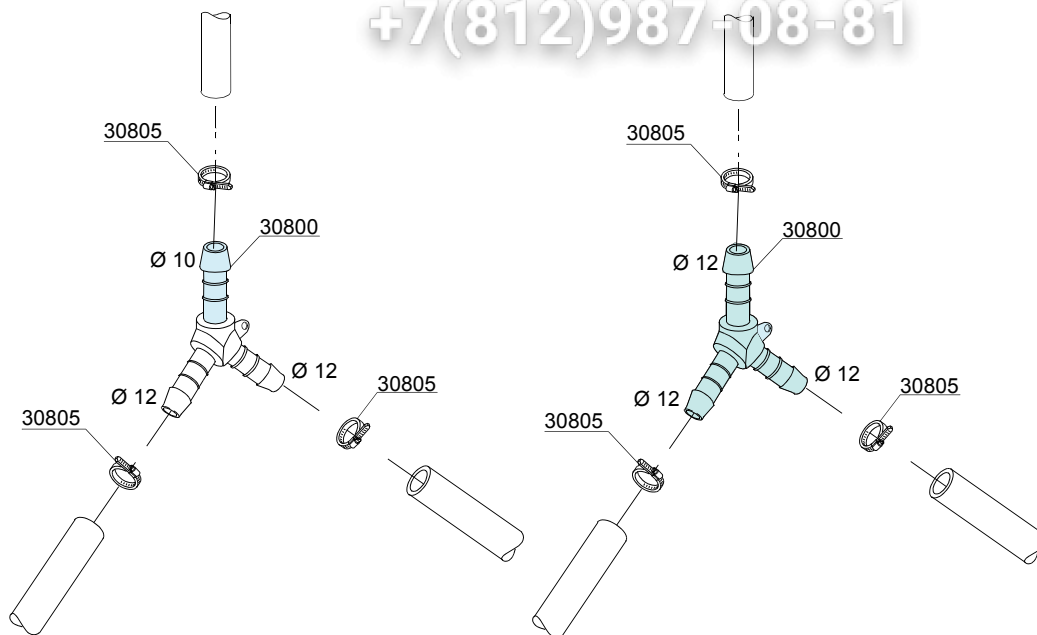

12_003ae

vsezip.ru

ID	P-code	SN from	SN to	Mod	Acces.	Volt	Description
Module:3 ways connection							
30800	540091		-	e,i			Ø12 mm plastic 3 ways connection
30805	11807		-	e,i			12/22 clamp (minimum 3 pieces)

e=ELECTRONICAL SWITCHES, uw=LOWER AND UPPER WASHING, i=INSULATED MODEL

29ELKC=29ELKC

bt=BREAK TANK, bp=BOOSTER PUMP, dvgw=DVGW, dd=DETERGENT DISPENSER, dp=DRAIN PUMP

A=3/N/PE~380-400V 50-60Hz, D=3/PE~200-210V 50-60Hz, F=2/PE~220-240V 50-60Hz, G=3/N/PE~415V 50-60Hz, H=3/PE~220-230V 50-60Hz, K=3/PE~380-400V 50-60Hz, L=3/PE~415V 50-60Hz, M=3/PE~440V 60Hz, P=1/N/PE~220-230V 50-60Hz, R=2/PE~220-240V 50-60Hz, U=1/N/PE~240V 50-60Hz, V=3/PE~240V 50-60Hz, W=1/N/PE~100-110V 50-60Hz

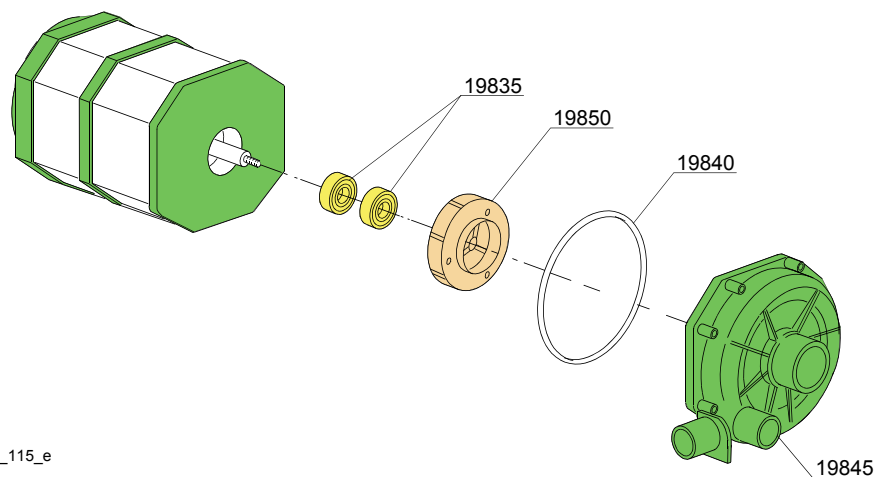
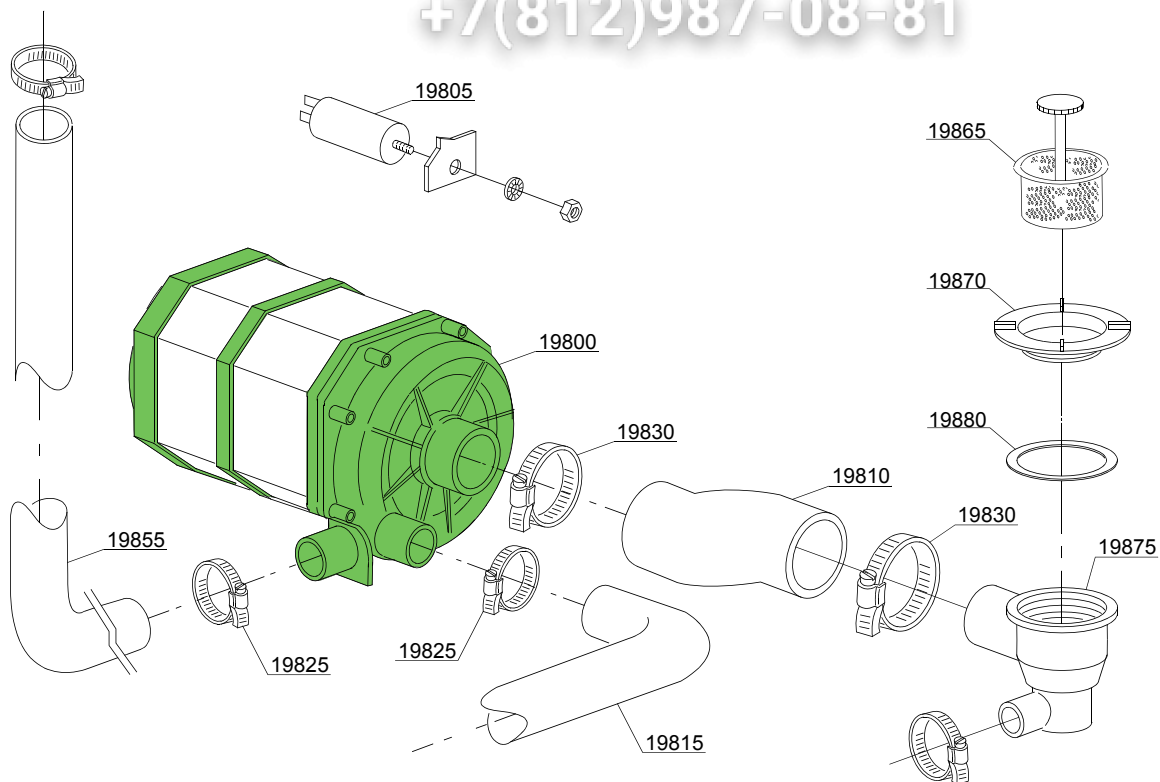

13_115_e

ID	P-code	SN from	SN to	Mod.	Acces.	Volt	Description
Module: Wash pump							
19800	150914		-	uw			0,70Hp wash pump - 230Vac 50Hz
19805	15081		-	uw			12,5 uF condenser
19810	25032/A		-	uw			Suction pipe coupling
19815	561017		-	uw			Low delivery pipe
19825	11806		-	uw			25/40 clamp (minimum 2 pieces)
19830	11809		-	uw			30/45 clamp (minimum 2 pieces)
19835	15080		-	uw			Rotating seals
19840	7130		-	uw			OR pump O-ring (minimum 2 pieces)
19845	16182		-	uw			Scroll
19850	15079/F		-	uw			Pump rotor
19855	561016		-	uw			Top delivery pipe EPDM
19865	561013		-	uw			Pump suction filter
19870	500615		-	uw			Ferrule with filter
19875	500606		-	uw			Right side scrap tray
19880	80208		-	uw			95x75x3 O-ring (minimum 2 pieces)

e=ELECTRONICAL SWITCHES, uw=LOWER AND UPPER WASHING, i=INSULATED MODEL

29ELKC=29ELKC

bt=BREAK TANK, bp=BOOSTER PUMP, dvgw=DVGW, dd=DETERGENT DISPENSER, dp=DRAIN PUMP

A=3/N/PE~380-400V 50-60Hz, D=3/PE~200-210V 50-60Hz, F=2/PE~220-240V 50-60Hz, G=3/N/PE~415V 50-60Hz, H=3/PE~220-230V 50-60Hz, K=3/PE~380-400V 50-60Hz, L=3/PE~415V 50-60Hz, M=3/PE~440V 60Hz, P=1/N/PE~220-230V 50-60Hz, R=2/PE~220-240V 50-60Hz, U=1/N/PE~240V 50-60Hz, V=3/PE~240V 50-60Hz, W=1/N/PE~100-110V 50-60Hz

vsezip.ru

+7(812)987-08-81

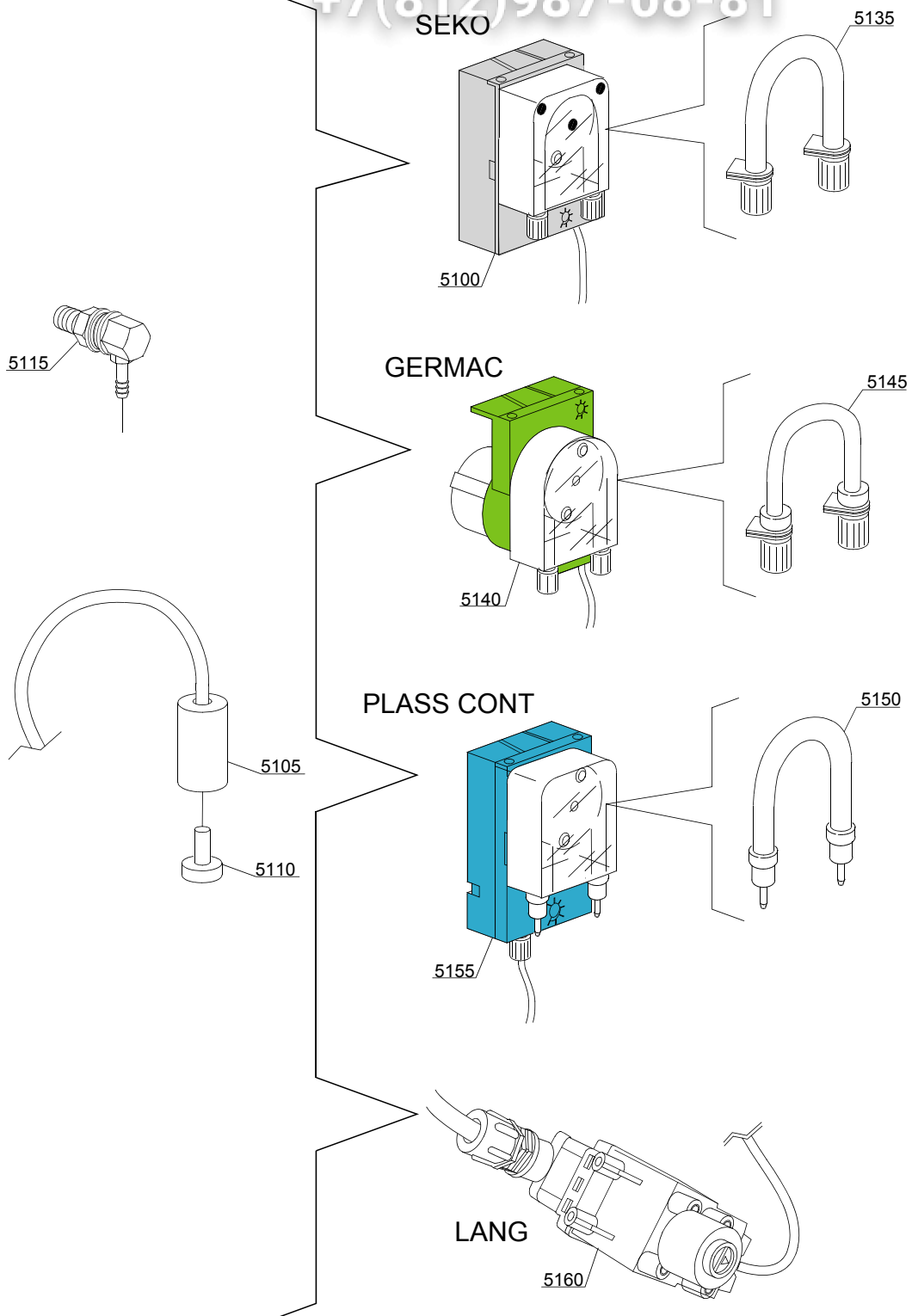

14_004_e

ID	P-code	SN from	SN to	Mod.	Acces.	Volt	Description
Module:Dosing detergent group							
5100	15985		-	i,e	dd		Seko detergent pump
5105	12525		-	i,e	dd		Ballast
5110	15058		-	i,e	dd		Small filter (minimum 3 pieces)
5115	15123		-	i,e	dd		Compleat stainless steel injector
5135	15185		-	i,e	dd		Seko thermoplastic pipe
5140	15985		-	i,e	dd		Germac detergent pump
5145	15108/E		-	i,e	dd		Germac thermoplastic pipe
5150	15985/A			i,e	dd		Plas Cont thermoplastic pipe
5155	15985			i,e	dd		Plas Cont detergent pump
5160	15108/L			i,e	dd		LANG detergent pump

e=ELECTRONICAL SWITCHES, uw=LOWER AND UPPER WASHING, i=INSULATED MODEL

29ELKC=29ELKC

bt=BREAK TANK, bp=BOOSTER PUMP, dvgw=DVGW, dd=DETERGENT DISPENSER, dp=DRAIN PUMP

A=3/N/PE~380-400V 50-60Hz, D=3/PE~200-210V 50-60Hz, F=2/PE~220-240V 50-60Hz, G=3/N/PE~415V 50-60Hz, H=3/PE~220-230V 50-60Hz, K=3/PE~380-400V 50-60Hz, L=3/PE~415V 50-60Hz, M=3/PE~440V 60Hz, P=1/N/PE~220-230V 50-60Hz, R=2/PE~220-240V 50-60Hz, U=1/N/PE~240V 50-60Hz, V=3/PE~240V 50-60Hz, W=1/N/PE~100-110V 50-60Hz

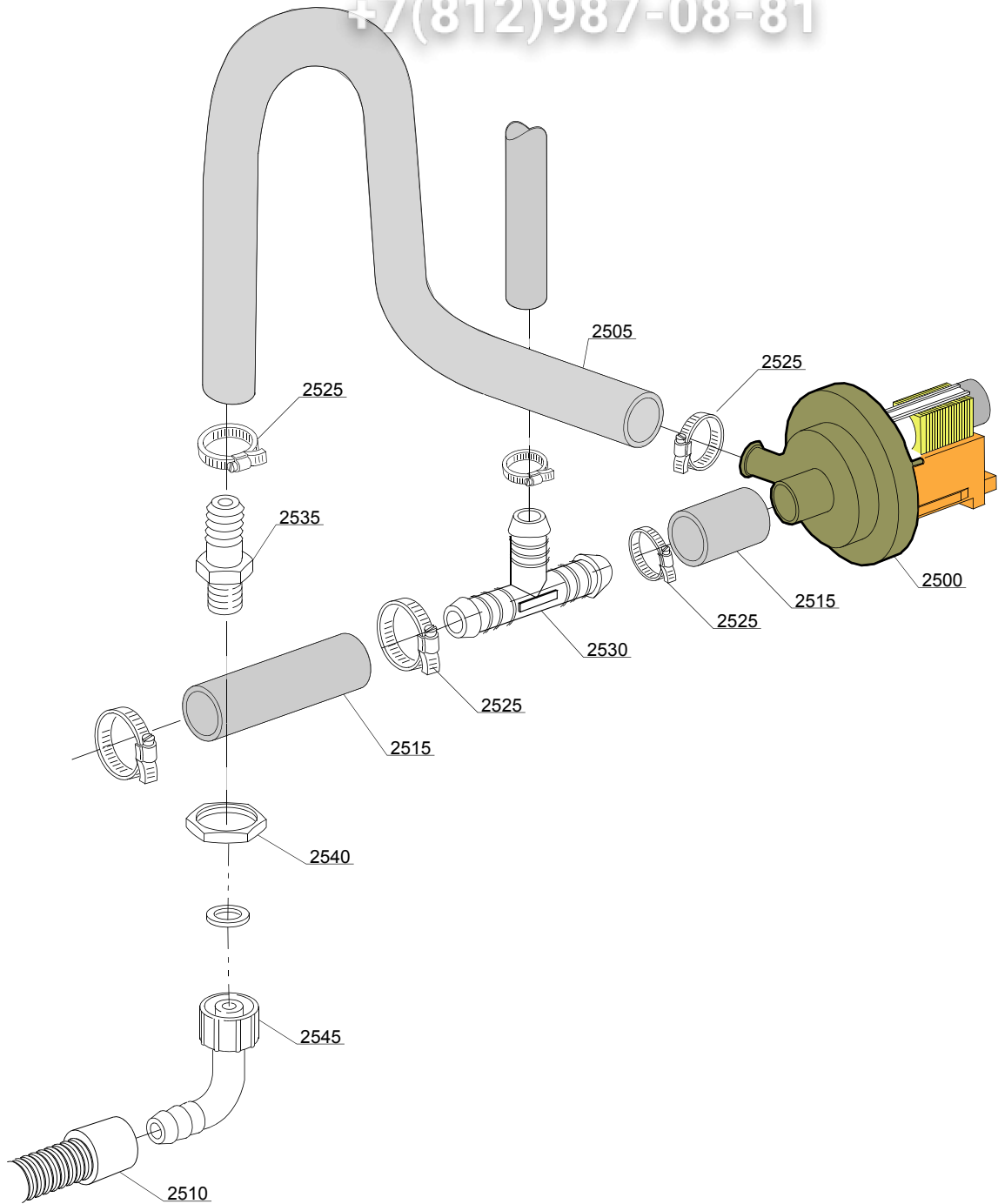

vsezip.ru

ID	P-code	SN from	SN to	Mod.	Acces.	Volt	Description
Module: Drain pump group							
2500	15101		-	i,e	dp		Drain pump 220/240V 50Hz
2505	561010		-	i,e	dp		H20 Prefomed coupling
2510	10727		-	i,e	dp		Drain pipe
2515	18044		-	i,e	dp		Ø28 top wash pipe
2525	11806		-	i,e	dp		25/40 clamp (minimum 2 pieces)
2530	540098		-	i,e	dp,bt		D25 3 ways connection for BREAK TANK(bt)
2535	18772		-	i,e	dp		Rubber holder 1"x25"
2540	11701/A		-	i,e	dp		Stainless steel nut
2545	18771		-	i,e	dp		Drain coude/pump connection pipe

e=ELECTRONICAL SWITCHES, uw=LOWER AND UPPER WASHING, i=INSULATED MODEL

29ELKC=29ELKC

bt=BREAK TANK, bp=BOOSTER PUMP, dvgw=DVGW, dd=DETERGENT DISPENSER, dp=DRAIN PUMP

A=3/N/PE~380-400V 50-60Hz, D=3/PE~200-210V 50-60Hz, F=2/PE~220-240V 50-60Hz, G=3/N/PE~415V 50-60Hz, H=3/PE~220-230V 50-60Hz, K=3/PE~380-400V 50-60Hz, L=3/PE~415V 50-60Hz, M=3/PE~440V 60Hz, P=1/N/PE~220-230V 50-60Hz, R=2/PE~220-240V 50-60Hz, U=1/N/PE~240V 50-60Hz, V=3/PE~240V 50-60Hz, W=1/N/PE~100-110V 50-60Hz

vsezip.ru

+7(812)987-08-81

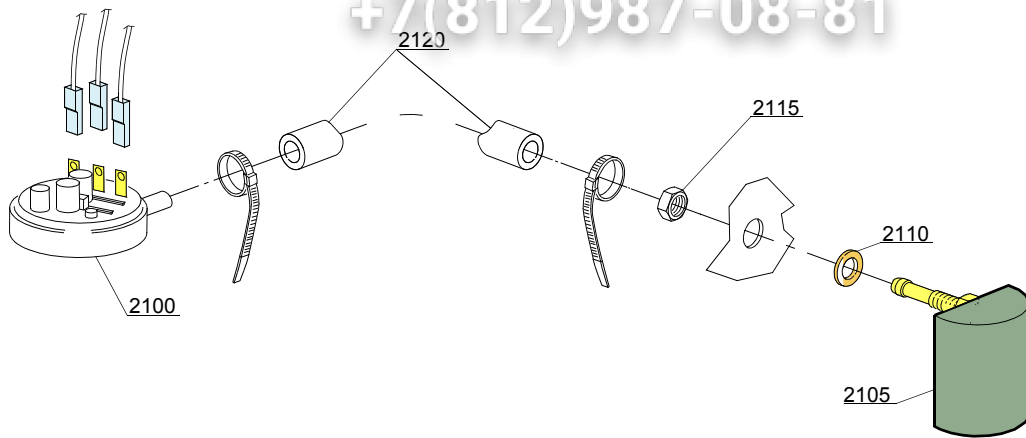

16_001_e

ID	P-code	SN from	SN to	Mod.	Acces.	Volt	Description
Module: Pressure switch group with air trap							
2100	10706/A		-	i,e			47-27 pressure switch
2105	135911/E		-	i,e			Grey air trap assembly
2110	13301		-	i,e			O-ring (minimum 10 pieces) - D14x8x1,5
2115	11702		-	i,e			M8 stainless steel nut (minimum 10 pieces)
2120	14508		-	i,e			4,5X9 EPDM rubber hose (minimum 2mt)

e=ELECTRONICAL SWITCHES, uw=LOWER AND UPPER WASHING, i=INSULATED MODEL

29ELKC=29ELKC

bt=BREAK TANK, bp=BOOSTER PUMP, dvgw=DVGW, dd=DETERGENT DISPENSER, dp=DRAIN PUMP

A=3/N/PE~380-400V 50-60Hz, D=3/PE~200-210V 50-60Hz, F=2/PE~220-240V 50-60Hz, G=3/N/PE~415V 50-60Hz, H=3/PE~220-230V 50-60Hz, K=3/PE~380-400V 50-60Hz, L=3/PE~415V 50-60Hz, M=3/PE~440V 60Hz, P=1/N/PE~220-230V 50-60Hz, R=2/PE~220-240V 50-60Hz, U=1/N/PE~240V 50-60Hz, V=3/PE~240V 50-60Hz, W=1/N/PE~100-110V 50-60Hz

vsezip.ru

+7(812)987-08-81

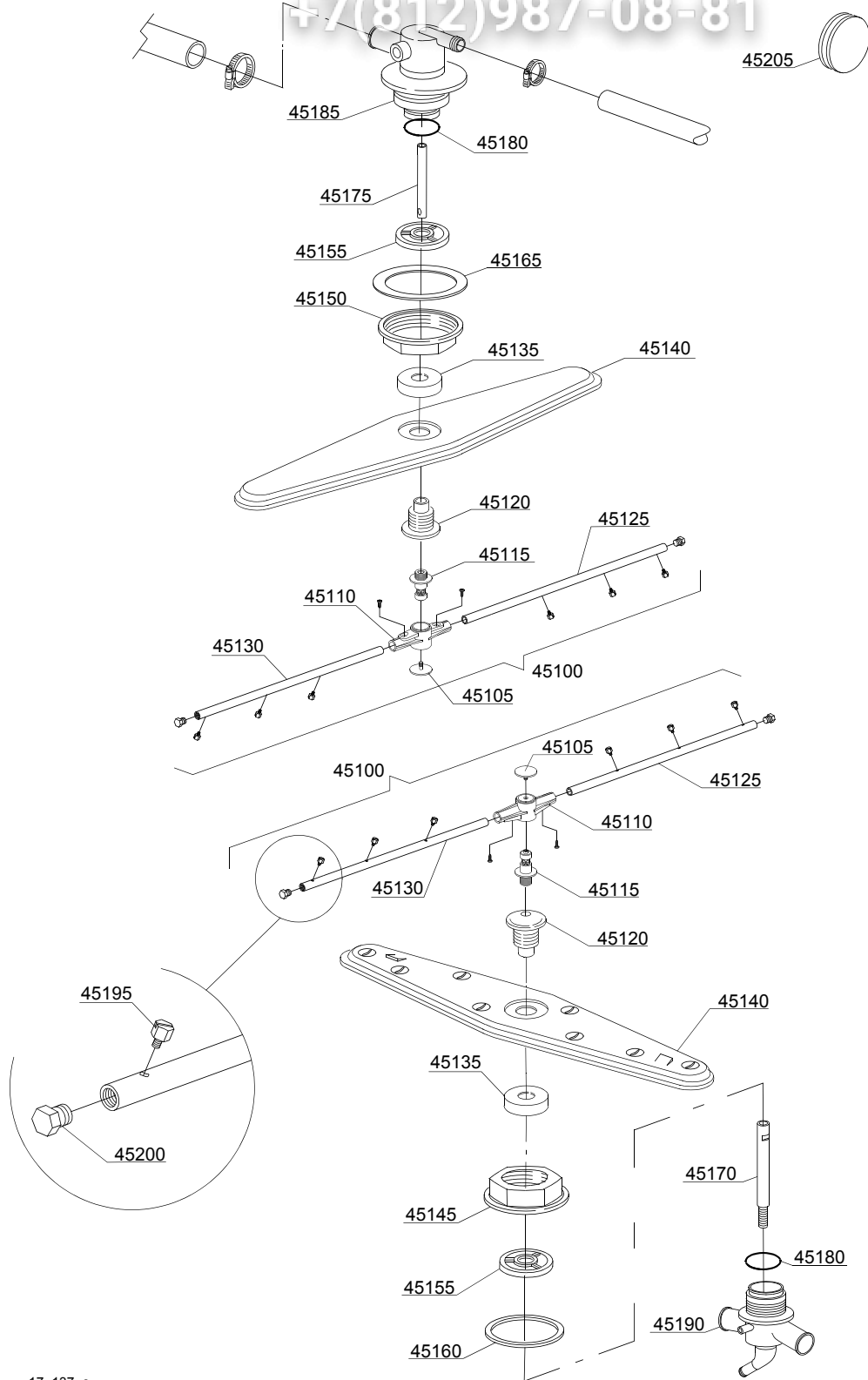

17_137_e

ID	P-code	SN from	SN to	Mod	Acces.	Volt	Description
Module:Turret group with rotating arms							
45100	75918		-	uw,e			Top/lower rinse arm complete
45105	10652		-	uw,e			Rinse arm screw
45110	10650		-	uw,e			Rinse arm
45115	10651		-	uw,e			Rinse axle
45120	500701		-	uw,e			Hub for rotor (inox rinse arm)
45125	10657		-	uw,e			Right rinse arm - stainless steel nozzle
45130	10658		-	uw,e			Left rinse arm - stainless steel nozzle
45135	500702		-	uw,e			Nut for wash arm bearing 05 (inox rinse arm)
45140	500700		-	uw,e			Stainless steel wash rotor
45145	540069		-	uw,e			Turret fixing nut
45150	540093		-	uw,e			Nut for top turret fixing
45155	540076		-	uw,e			Guide pipe
45160	540034		-	uw,e			Plain O-ring
45165	540032		-	uw,e			Plain O-ring (minimum 2 pieces)
45170	561032		-	uw,e			Upper stainless steel wash rotor rinse axle AP
45175	561034		-	uw,e			Under stainless steel wash rotor rinse axle AP
45180	561035		-	uw,e			AP seal ring
45185	561033		-	uw,e			AP top turret stainless steel wash rotor
45190	561031		-	uw,e			AP under turret stainless steel wash rotor
45195	560018		-	uw,e			Stainless steel rinse nozzle
45200	560017		-	uw,e			Rinse arm plug
45205	13316/A		-	uw,e			DVGW hole O-ring

e=ELECTRONICAL SWITCHES, uw=LOWER AND UPPER WASHING, i=INSULATED MODEL

29ELKC=29ELKC

bt=BREAK TANK, bp=BOOSTER PUMP, dvgw=DVGW, dd=DETERGENT DISPENSER, dp=DRAIN PUMP

A=3/N/PE~380-400V 50-60Hz, D=3/PE~200-210V 50-60Hz, F=2/PE~220-240V 50-60Hz, G=3/N/PE~415V 50-60Hz, H=3/PE~220-230V 50-60Hz, K=3/PE~380-400V 50-60Hz, L=3/PE~415V 50-60Hz, M=3/PE~440V 60Hz, P=1/N/PE~220-230V 50-60Hz, R=2/PE~220-240V 50-60Hz, U=1/N/PE~240V 50-60Hz, V=3/PE~240V 50-60Hz, W=1/N/PE~100-110V 50-60Hz