

Зип Общепит

vsezip.ru

+7(812)987-08-81



**FSD2B-0PR01**

**Edition 20101101-**

Зип Ощепит

vsezip.ru

+7(812)987-08-81

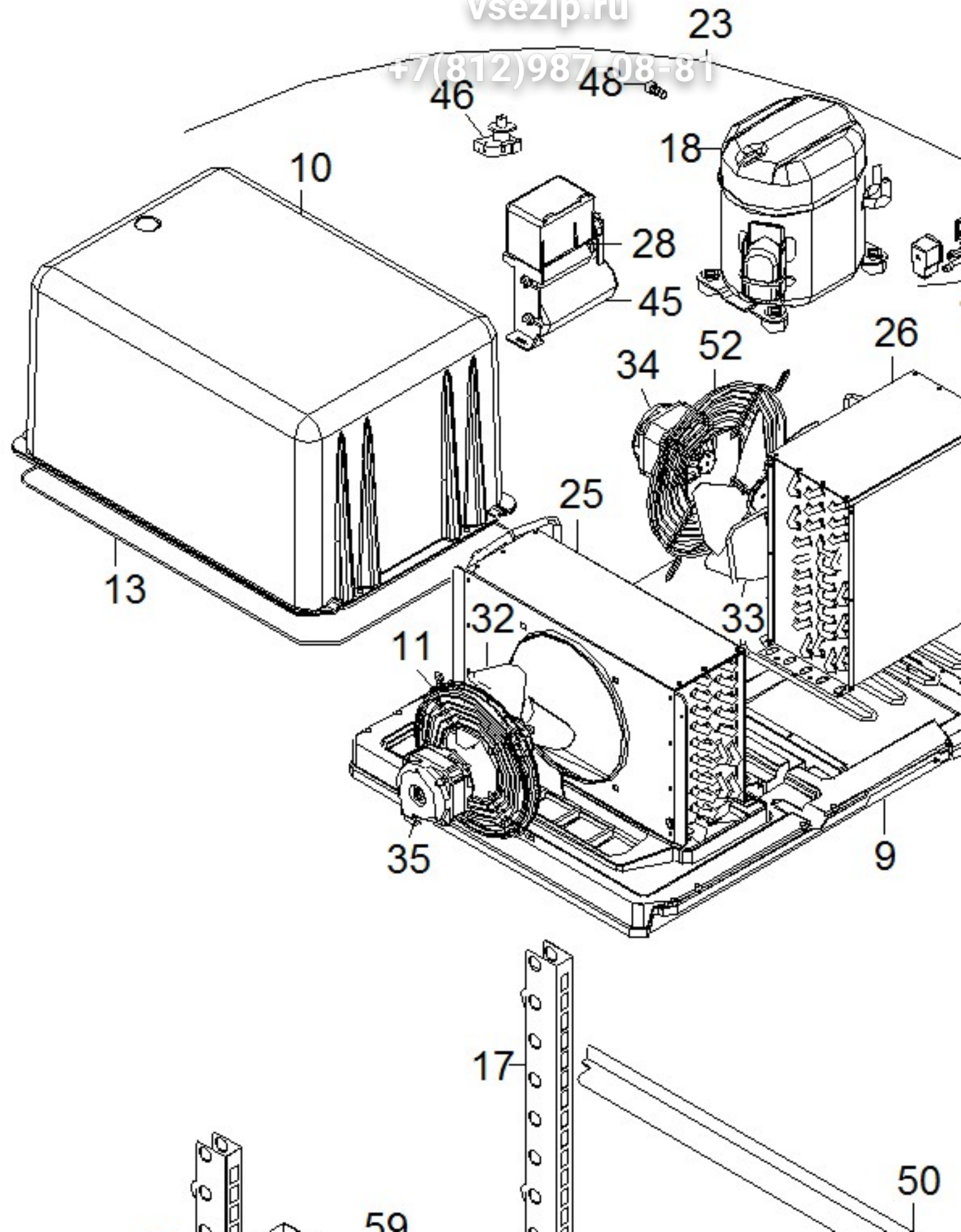

Pos	Code	Description	Info
001	3065170	FRAME TRIM	15/03/2008-
002	3065480	SUPPORT	15/03/2008-
003	3082260	TOP BRACKET	15/03/2008-
004	3082370	HOLE PLUG	15/03/2008-
005	3091340	DOOR PLUG	15/03/2008-
006	3091350	BOTTOM BRACKET	15/03/2008-
007	3096020	MICROSWITCH	15/03/2008-
008	3096620	LOCK SUPPORT	15/03/2008-
009	3097250	BUFFER	15/03/2008-
010	3097260	BONNET	15/03/2008-
011	3097570	FAN.PROT.	15/03/2008-
012	3098940	DEFROST SOL.VALVE	15/03/2008-
013	3110390	HEATING ELEMENT	15/03/2008-
014	3120670	CONTROL BOARD	15/03/2008-
015	3120700	COMPONENT GUARD	15/03/2008-
016	3123690	RACK	28/04/2009-
017	3123640	RACK	15/03/2008-
018	3155540	COMPRESSOR R404A (BT)	15/03/2008-
019	3131090	FRAME TRIM	15/03/2008-
020	3131140	RESISTOR	15/03/2008-
021	3131150	FRIDGE DOOR	15/03/2008-
022	3095300	SILK-SCREE.PANEL	15/03/2008-
023	3133790	MOTOR UNIT	15/03/2008-
024	3134000	ELECTRONIC CARD	15/03/2008-
025	3189530	EVAPORATOR	01/11/2010-
026	3134460	CONDEN.+BAFFLE	15/03/2008-
027	3134600	PIPE COIL	15/03/2008-
028	3142540	CONDENSER	15/03/2008-
029	32A2200	POWER SUPPLY CABLE	15/03/2008-
030	32D0020	CABLE CLAMP Ø 4 - 12	15/03/2008-
031	32D0761	TERMINAL BOARD	15/03/2008-
032	32M1100	FAN	15/03/2008-
033	32M2510	FAN	15/03/2008-
034	32M7210	FAN MOTOR	15/03/2008-
035	32M7240	FAN MOTOR	15/03/2008-
036	32V3720	RELAY	15/03/2008-
037	32V3730	NTC PROBE	15/03/2008-
038	32V6010	EVAPORATOR PROBE NTC	15/03/2008-
039	32W3790	LIGHT	15/03/2008-
040	32W3800	LAMP-HOLDER	15/03/2008-
041	32W3970	BIPOLAR SWITCH	15/03/2008-
042	32X0120	GROMMET Ø 21	15/03/2008-
043	32X0140	GROMMET Ø13,5-Ø25	15/03/2008-
044	32X0200	GROMMET Ø7.5-Ø11.5	15/03/2008-
045	32Z9120	CONDENSER	15/03/2008-
046	3154410	RELAY	15/03/2008-
047	33A0190	FILTER	15/03/2008-
048	33A1200	AUXIL.VALVE	15/03/2008-
049	35Y3090	LAMP GUARD	15/03/2008-
050	35Y9660	GUIDE	15/03/2008-
051	35Y9670	GUIDE	15/03/2008-

Pos	Code	Description	Info
052	36C2031	FAN GUARD	15/03/2008-
053	3137690	FOOT	19/04/2010-
054	36E2240	LAMP PROTECTION GLASS SLIDE	15/03/2008-
055	36G6520	HINGE	15/03/2008-
056	36M7070	KEY LOCK	15/03/2008-
057	36M7080	HINGE	15/03/2008-
058	37Q5520	DOOR GASKET	15/03/2008-
059	3169750	CONVEYOR	28/04/2009-