

Зип Общежит Мод. ММ 10 ЕВ

vsezip.ru

+7(812)987-08-81

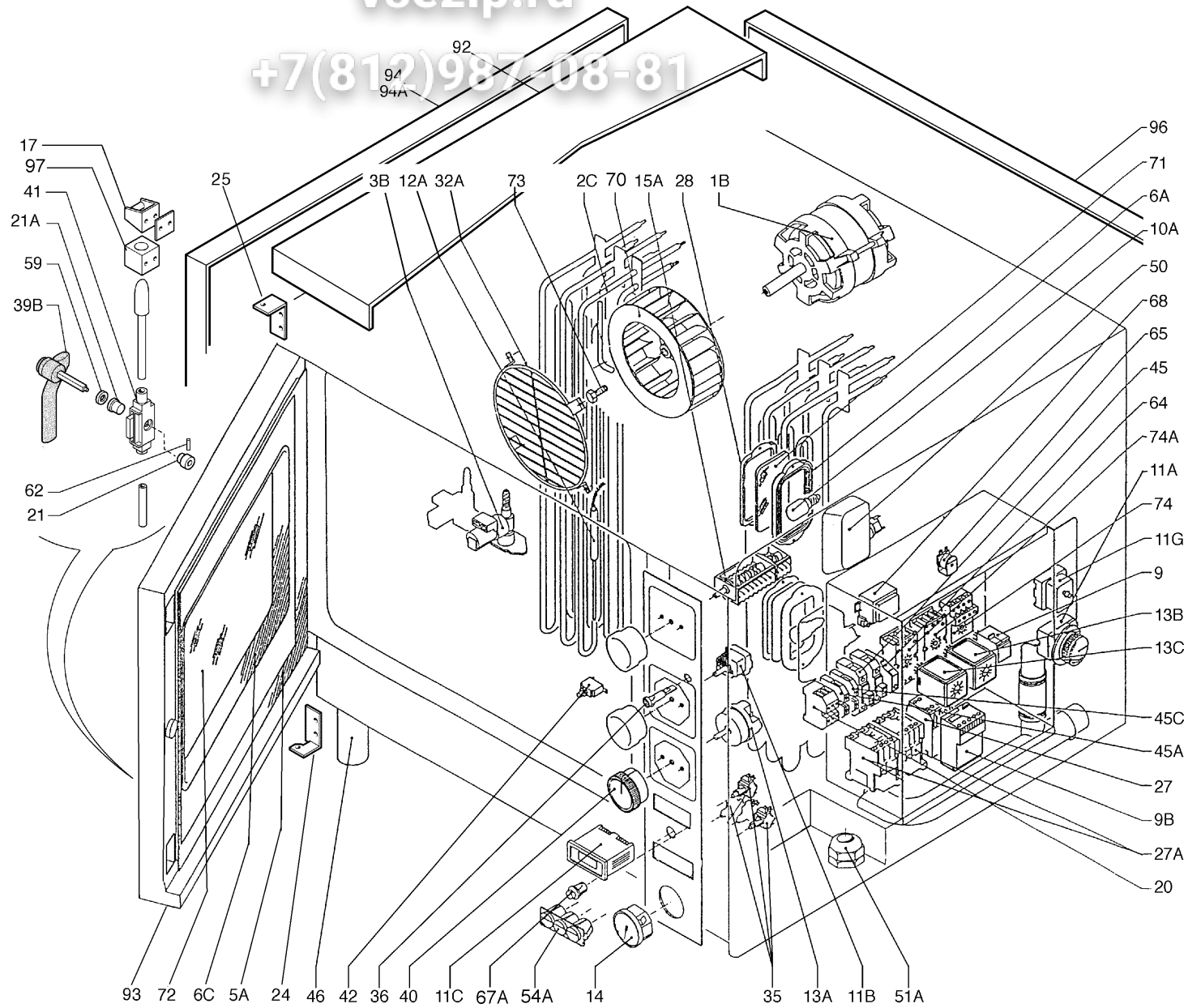

Зип Общежит

Mod. MM 10 EB

vsezip.ru

+7(812)987-08-81

Pos. Item	CODICE CODE CÓDIGO	DESCRIZIONE	ITEM DESCRIPTION	DÉSIGNATION ARTICLES	ARTIKELBESCHREIBUNG	DESCRIPCIÓN ARTÍCULOS
1b	0840	Motore trifase	Three-phase motor	Moteur triphasé	Dreiphasen-Motor	Motor trifásico
2c	1466	Resistenza	Heating element	Resistance	Widerstand	Resistencia
3b	0282	Elettrovalvola	Solenoid valve	Électrovanne	Magnetventil	Electroválvula
5a	3352	Guarnizione porta	Door seal	Joint porte	Türdichtung	Junta puerta
6a	3543	Guarnizione vetro	Glass seal	Joint de verre	Dichtung Für Lampenglas	Junta vidrio
6c	0489	Guarnizione vetro	Glass seal	Joint vitre	Dichtung Für Glass	Junta vidrio
9	10504	Relè	Relay	Relais	Relais	Relé
9b	10003	Relè	Relay	Relais	Relais	Relé
10a	3546	Lampadina 25W	25W lamp	Ampoule 25W	Lampe 25W	Bombilla 25W
11a	10008	Termostato	Thermostat	Thermostat	Thermostat	Termostato
11b	0283	Termostato	Thermostat	Thermostat	Thermostat	Termostato
11c	1549	Termostato	Thermostat	Thermostat	Thermostat	Termostato
11g	0154	Termostato	Thermostat	Thermostat	Thermostat	Termostato
12a	10402	Sonda a spillone	Needle sensor	Sonde pointeau	Niveaufühler	Sonda a aguja
13a	3433	Temporizzatore	Timer	Minuteur	Zeitregler	Temporizador
13b	10501	Temporizzatore	Timer	Minuteur	Zeitregler	Temporizador
13c	10502	Temporizzatore	Timer	Minuteur	Zeitregler	Temporizador
14	0594	Termometro	Thermometer	Thermomètre	Thermometer	Termómetro
15a	3018	Commutatore	Selectore	Commutateur	Umschalter	Commutador
17	3738.1	Ass. Aggancio	Hook assembly	Ens. Clochet	Satz Enhakung	Conjunto enganche
20	10201	Blocco morsetti	Terminal block	Bloc bornes	Einheit Klemmen	Bloque bornes
21	3736.1	Boccola	Bush	Bague	Buchse	Casquillo
21a	3734	Boccola	Bush	Bague	Buchse	Casquillo
24	0321.05	Cerniera inf. Porta	Bottom door hinge	Charnière inf. Porte	Unteres Türscharnier	Gozne inferior puerta
25	0322c	Cerniera sup. Porta	Top door hinge	Charnière sup. Porte	Oberes Türscharnier	Gozne superior puerta
27	10001	Contattore	Contactore	Contacteur	Verbinder	Contactore
27a	10004	Contattore	Contactore	Contacteur	Verbinder	Contactore
28	3545	Cornice vetro	Glass frame	Cadre	Rahmen	Marco vidrio
32a	0672	Griglia	Grid	Grille	Schutzgitter	Rejilla
35	3473	Interruttore	Switch	Interrupteur	Schalter	Interruptor
36	0592	Lampada spia arancio	Orange lamp	Témoins orange	Orange Kontrollleuchte	Indicador luminoso naranja
39b	3700.2	Maniglia	Handle	Poignée	Griff	Manilla
40	0898	Manopola	Knob	Manette	Dreheschalter	Mando
41	3747	Meccanismo centrale	Closing central mechanism	Mécanisme central	Zentraler Mechanismus	Mecanismo central
42	1519	Micrinterruttore	Door microswitch	Micro interrupteur	Mikroschalter	Micrinterruptor
45	10204	Morsetto portafusibile	Fuse-holder terminal	Borne a fusible	Sicherungsklemme	Borne portafusibile
45a	10202	Morsetto blu	Blue terminal	Borne bleue	Klemme Blau	Borne azul
45c	10203	Morsetto giallo/verde	Yellow/green terminal	Borne jaune/verte	Klemme Gelb/Grün	Borne amarillo/verde
46	15012	Piedino corto	Short foot	Pied court	Kurzer Fuß	Pie corto
50	3542	Portalampada	Lamp holder	Douille pour ampoule	Lampenhalter	Portalámparas
51a	1362	Pressacavo	Cable lock	Serre câble	Kabelklemme	Prensahilo
54a	10044	Pulsanti	Push buttons	Bouton	Zweipoliger	Botón
59	3754	Rondella	Washer	Rondelle	Beilagscheibe	Arandela
62	3780	Spina	Locking pin	Goupille élastique	Elastischer Stift	Clavija elástica
64	10205	Staffa terminale	Terminal bracket	Etrier final	Ösenendstück	Estribo terminal
65	10031	Suoneria	Bell	Sonnerie	Akustisches Signal	Avisador acústico
67a	10045	Pulsante	Key	Touche	Taste	Tecla
68	1551	Trasformatore	Transformer	Transformateur	Transformator	Transformador
70	3196	Ventola	Fan	Ventilateur	Gebälse	Ventilador
71	3544	Vetro lampada	Glass for lamp holder	Verre ampoule	Glass Für Lampe	Vidrio lámpara
72	1714	Vetrocamera	Double glazing	Double vitrage	Termoglas	Doble acristalado
73	0839	Vite	Screw	Vis	Schraube	Tornillo
74	10505	Zoccolo	Base	Support	Halter	Zócalo
74a	10503	Zoccolo	Base	Support	Halter	Zócalo
92	3861	Coperchio	Cover	Couvercle	Abdeckung	Tapa
93	2237	Kit ass.porta	Assembly door kit	Kit ens. Porte	Kit Satz Tuer	Kit conjunto puerta
94	3134	Fianco sinistro	Lh side	Cote gauche	Linke Seitenwand	Lado izdo.
94a	3142	Fianco destro	Rh side	Cote droit	Rechte Seitenwand	Lado dcho.
96	3990	Schienale	Back	Panneau arriere	Rückwände	Trasera
97	3775	Blochetto serratura	Lock block	Bloc serrure	Schlossblock	Bloque cerradura